

EMRP dissemination event 2011

iMERA-plus – results

29 November 2011
Brussels

Jörn Stenger, EMRP Chair

EU-cofunded joint metrology research

The EMRP

- coordinates national metrology research programmes of 22 European states
- has a jointly developed and agreed strategic research agenda
- central EURAMET e.V. financial management contracts directly with partners
- all 37 member states of wider EURAMET with benefit from implementation

integral part of a wider,
longer term initiative

EMRP 169/185

400 M€ (50% from EU, 7 years)

iMERA ERA-NET +

63 M€ (1/3 from EU, 3 years)

iMERA ERA-NET

6th FP

7th FP

2005

2006

2007

2008

2009

2010

Respond to societal needs:

- prepare integrated knowledge base and reliable reference data for regulation and policy making
- grand challenges

Respond to industrial needs:

- prepare better services (traceability)
- give high-end measurement technology push for industrial competitiveness

Respond to scientific needs:

- Steve Chu, Nobel laureate 1997: "Accurate measurement is at the heart of physics, and in my experience new physics begins at the next decimal place."
- prepare the long-term measurement capabilities without asking for immediate application

- wide range of stakeholders
- different types of impact
- different type of approaches

On the basis of technical roadmaps, stakeholder consultations;
ten years perspective

Grand Challenges

- Health
- Energy
- Environment
- New Technologies

Focussed metrology R&D

- Fundamental metrology
- Applied metrology responding to industrial needs

iMERA-plus TPs
(Targeted Programmes)

Metrology R&D for

- Health
- Fundamentals of the SI
- Length
- Electromagnetism



Cycle of implementation, e.g. TP Health

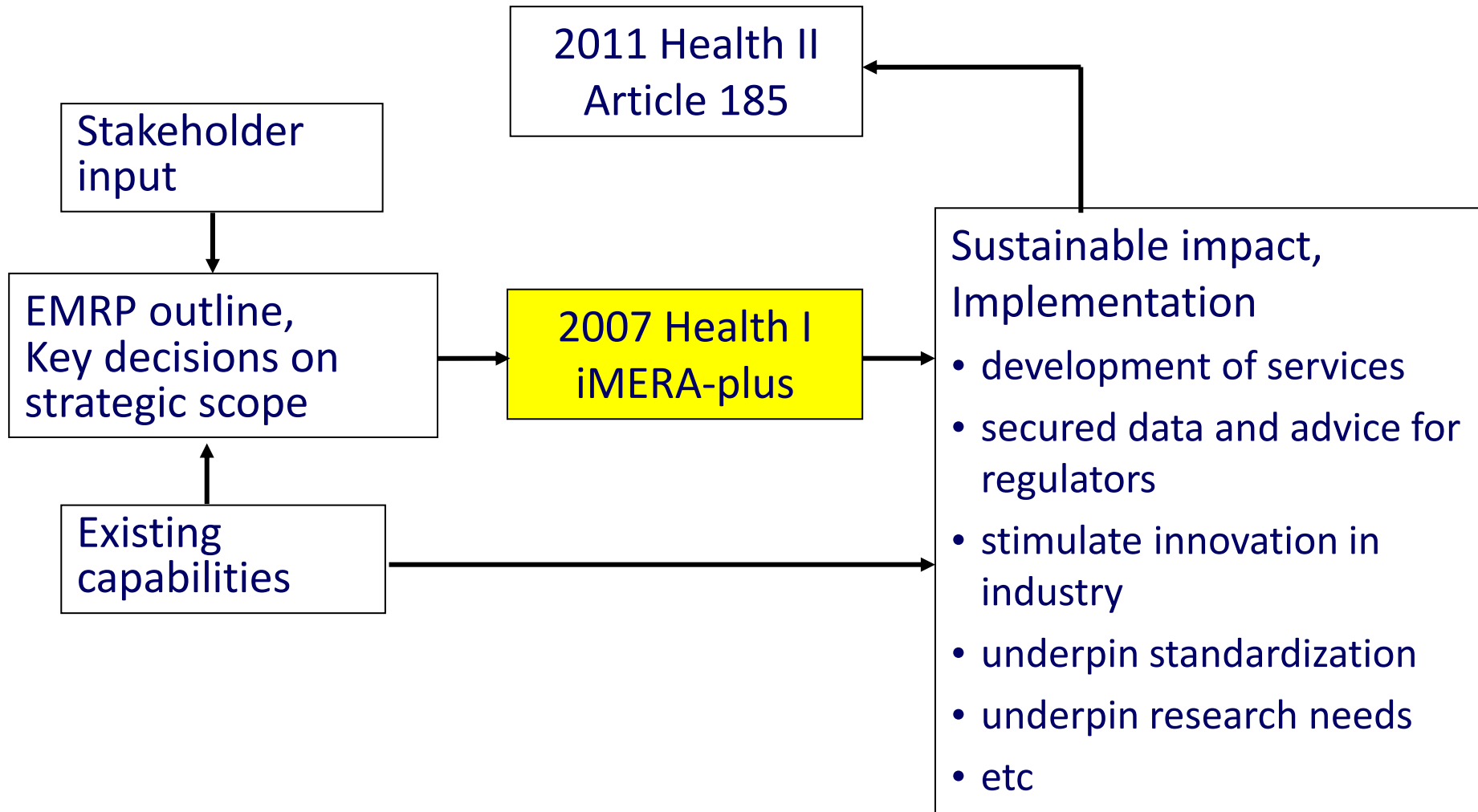

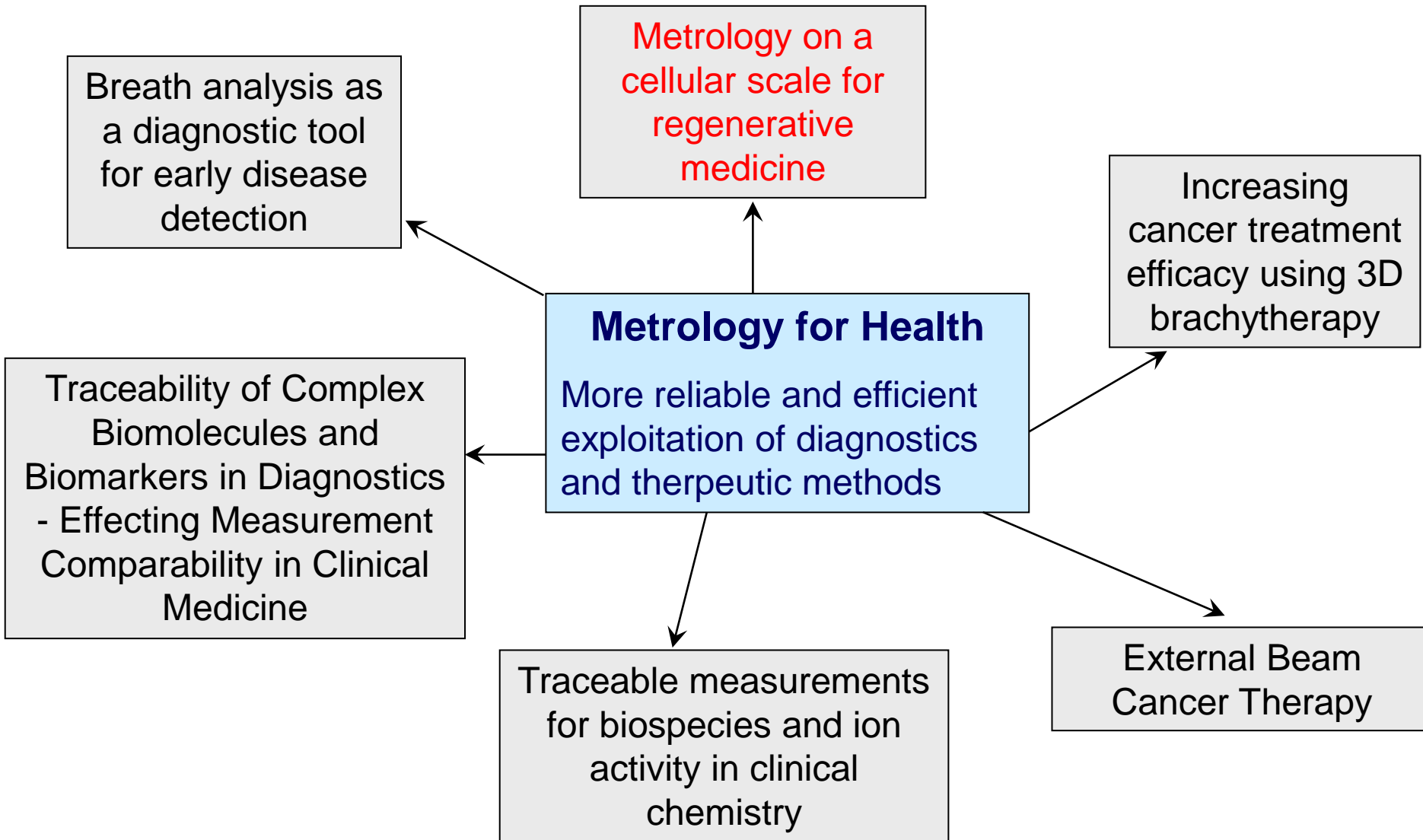

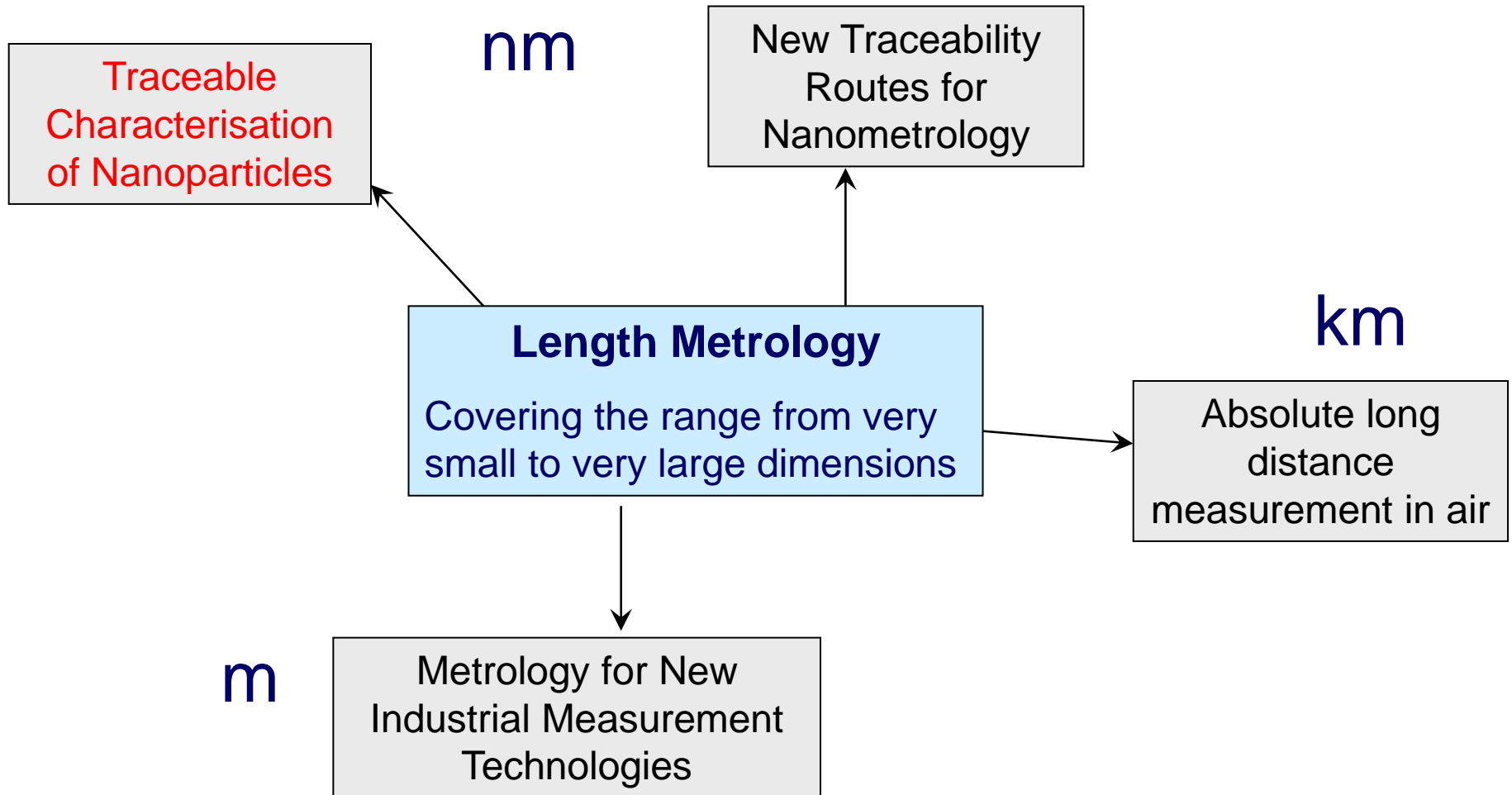

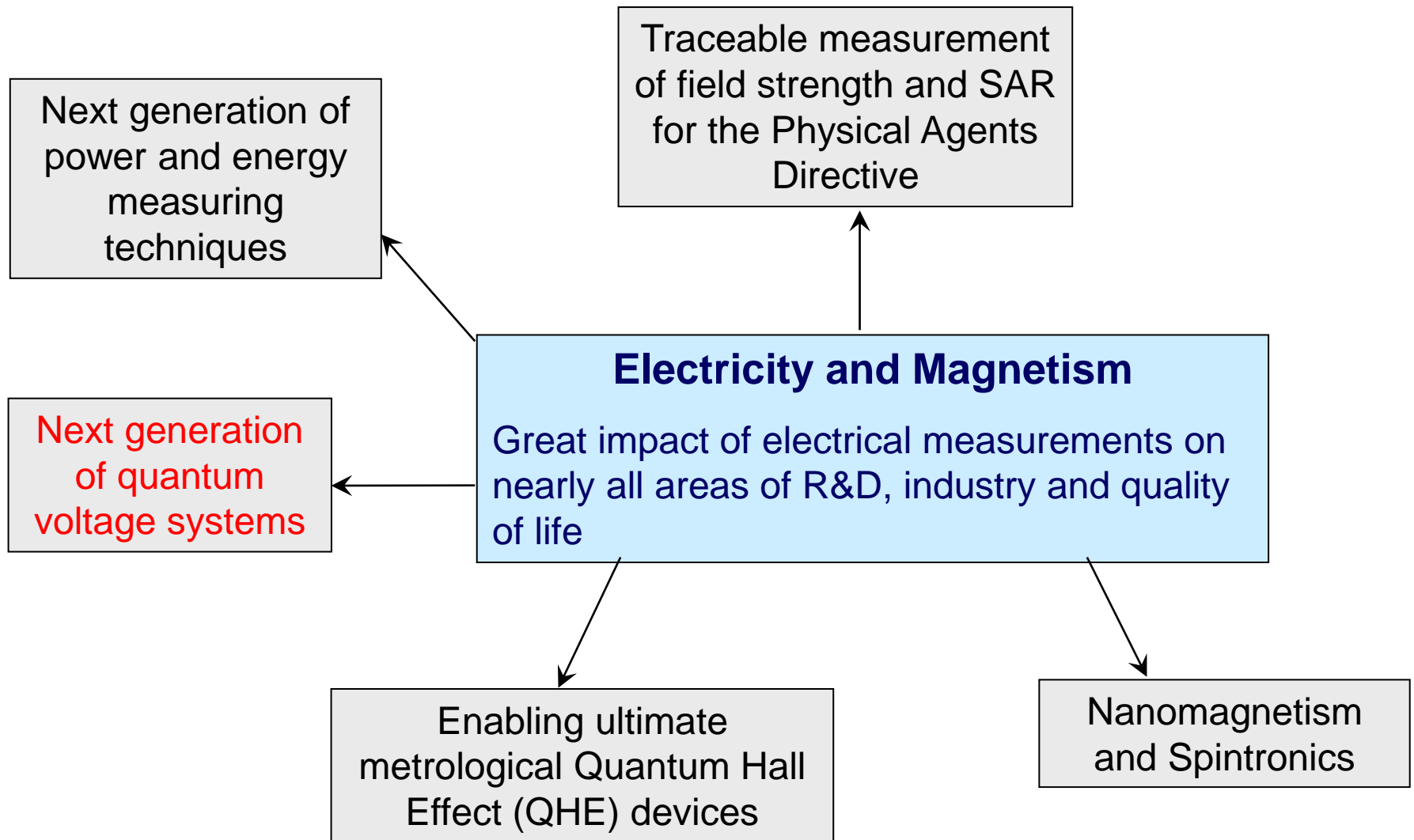

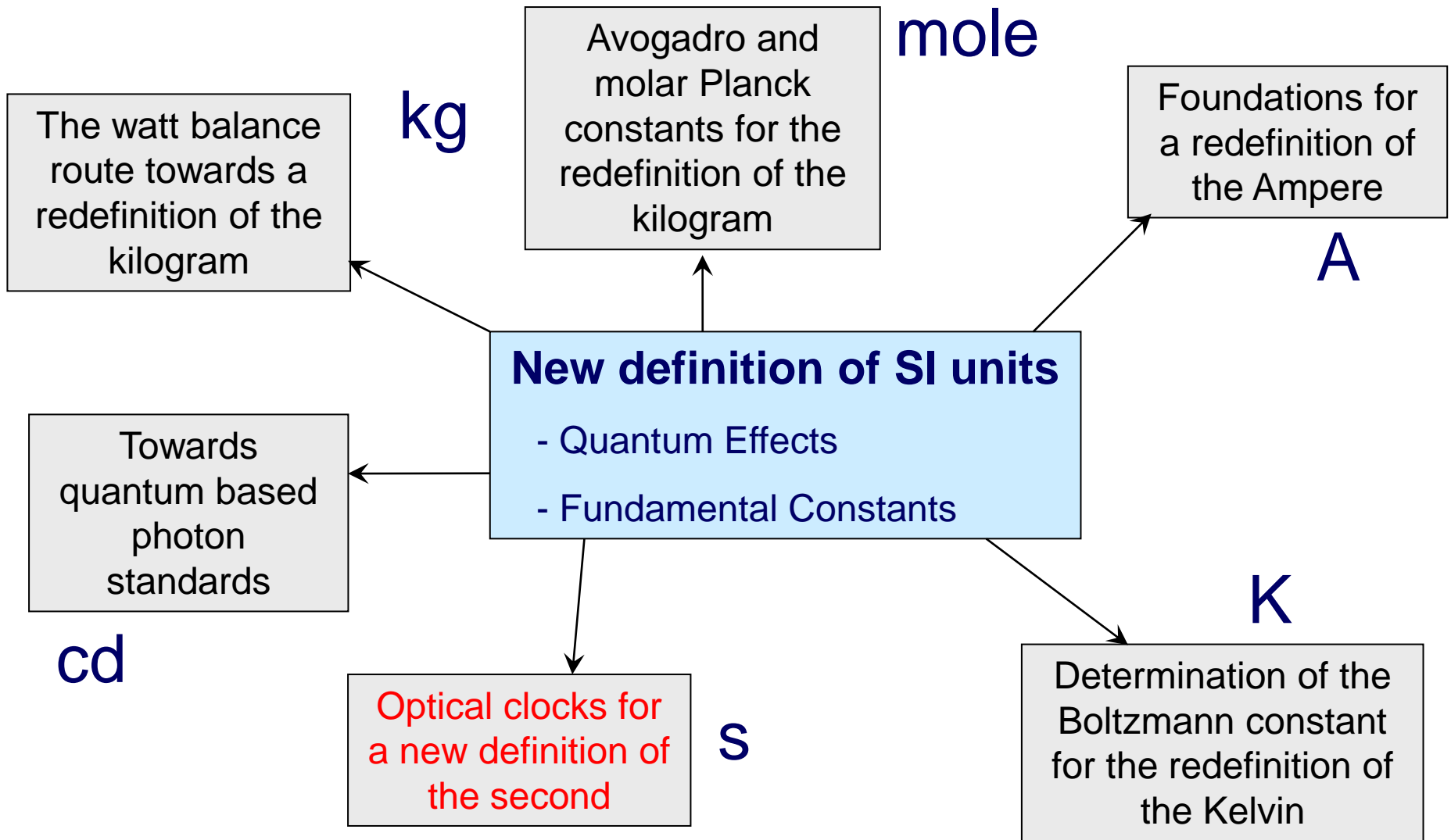

TP Health

Project “Regenmed”

Metrology on a cellular scale for regenerative medicine

- develop robust procedures for cell growth measurement and characterisation
- define cost effective metrics for assessing the consistency of products containing living cells

iMERA-plus: responding to grand challenges

new spectroscopic
imaging methods

monitoring of cell growth
on biocompatible surfaces

cell differentiation

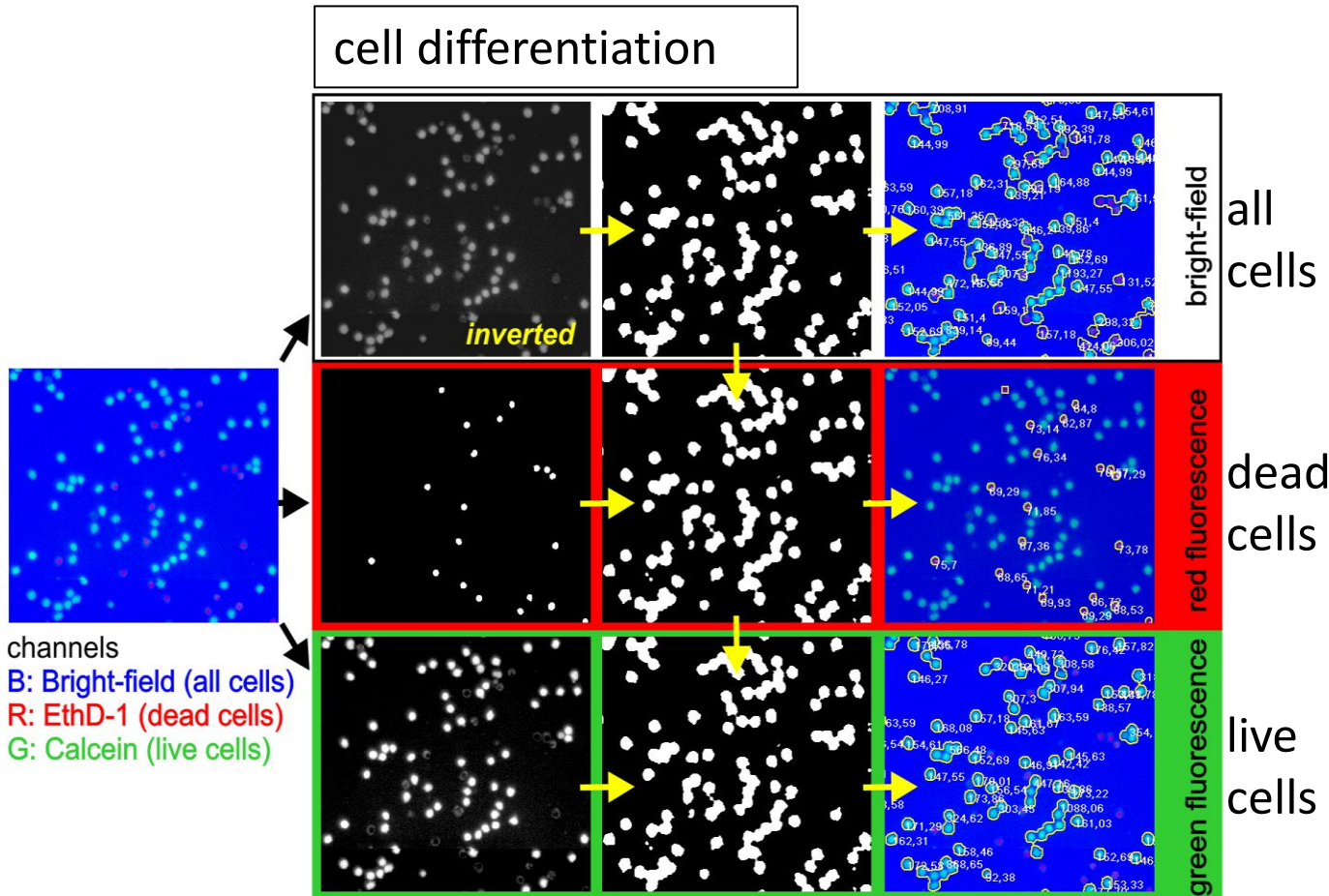

15 min

30 min

45 min

60 min

TP Length

Project Nanoparticles

Traceable characterisation of nanoparticles

Dimensional traceability for a range of nanoparticle measurement techniques:

- Scanning Probe Microscopy (SPM)
- Scanning Transmission Electron Microscopy (STEM)
- Transmission Electron Microscopy (TEM)
- Scanning Electron Microscopy (SEM)
- Dynamic Light Scattering (DLS)
- Small Angle X-ray Sattering (SAXS)

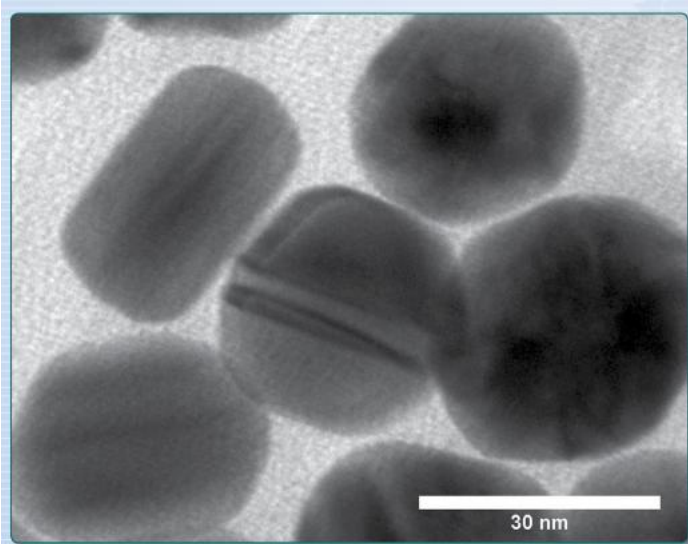

TEM image of 30 nm gold nanoparticles. Note that the shape of the particles is not quite spherical.

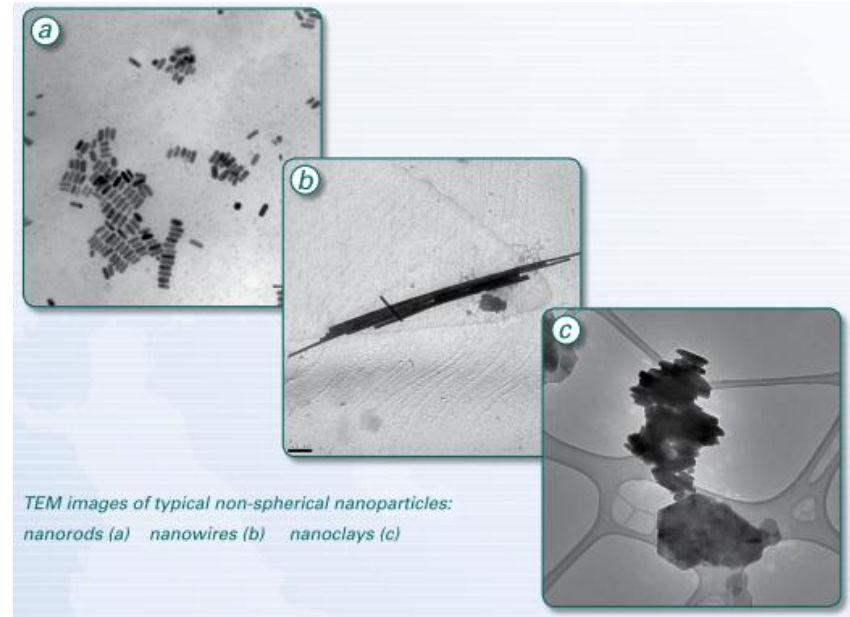

TEM images of typical non-spherical nanoparticles:
nanorods (a) nanowires (b) nanoclays (c)

- Ground work for understanding nanoparticles and their characterization
- Contributed to European Reference materials for Nanoparticles
- Fed into standardisation: ISO TC229 Nanotechnologies
ISO TC24 Particle characterisation
- Prepared the ground for follow-up projects

→ Key developments responding to industrial needs

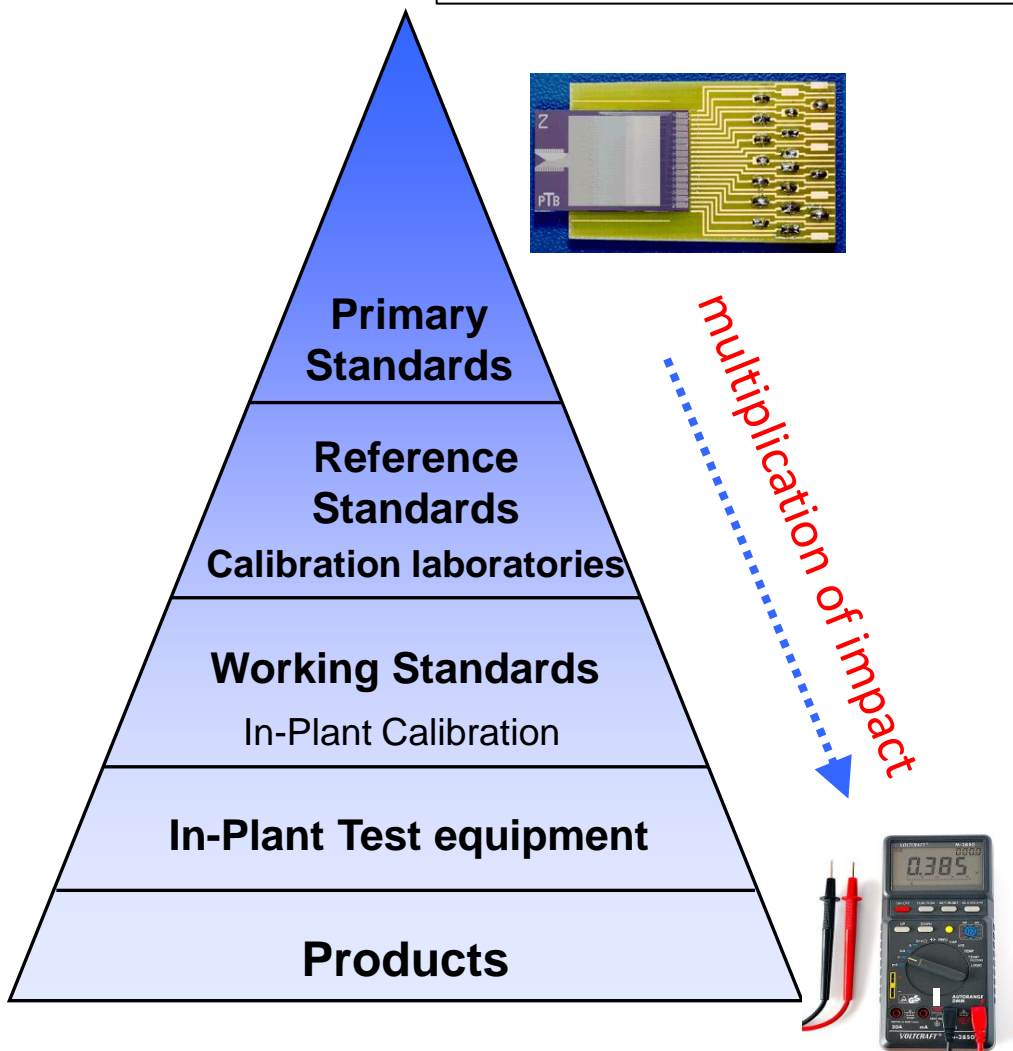

TP EM
Project JoSy

**New generation of
intrinsically stable quantum
voltage systems**

→ enabling numerous previously unavailable calibrations for thermal converters, ADCs and DACs, inductive dividers, spectrum analysers, waveform generators, etc

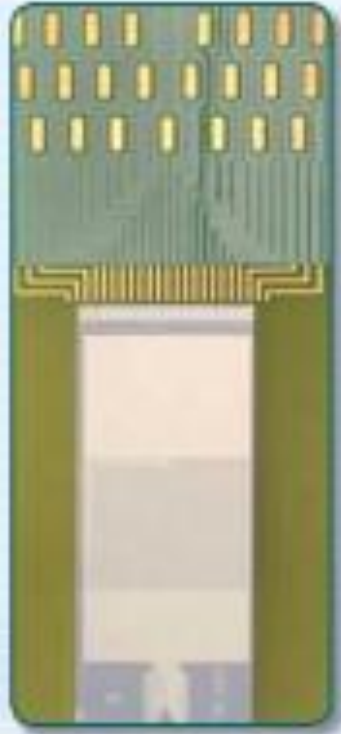

new fabrication technology
(e.g. for 70000-junction 10 V device)

new calibration capabilities

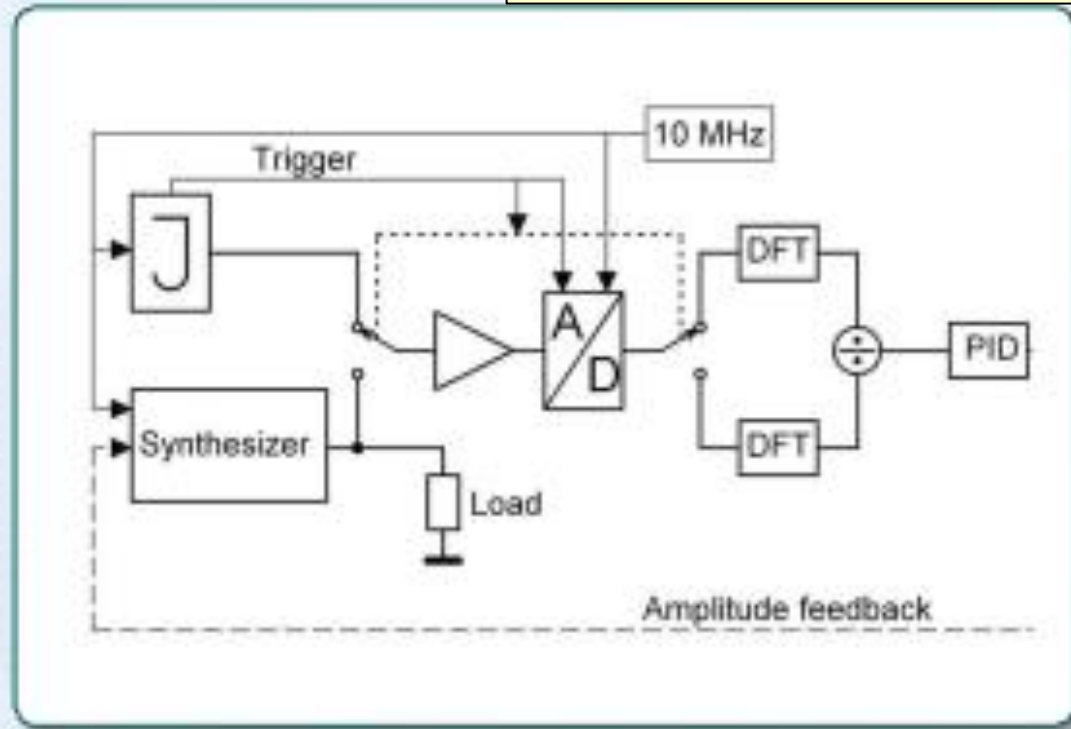

▲ Schematic diagram of the Josephson voltage standard locked synthesizer (JoLoS).

- significant improvements on primary level
- technology transfer to esz GmbH
- follow-up technology transfer projects

will multiply through calibration chain

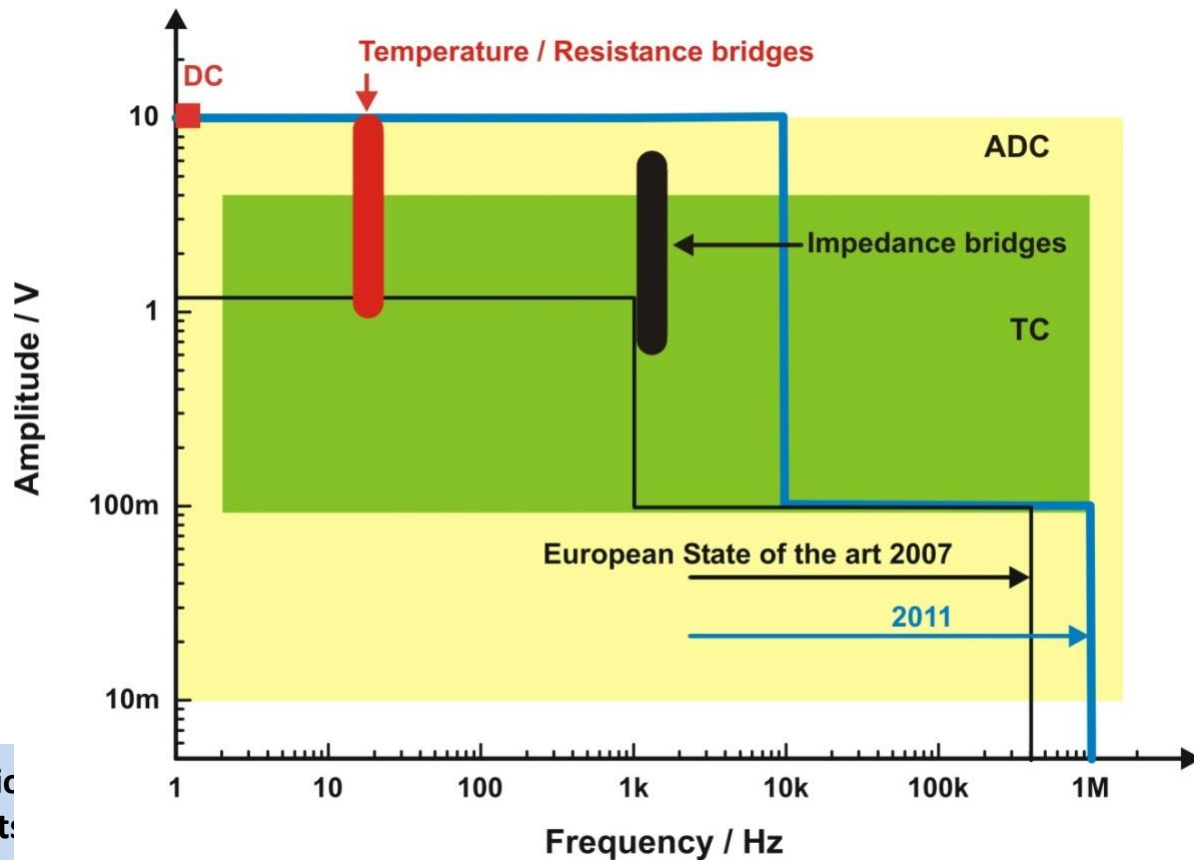
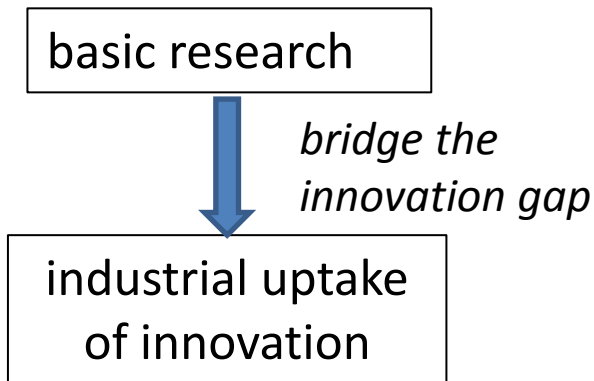

Improve time/frequency references for immediate **scientific use** and **long-term industrial and societal use**

TP SI units
Project OCS

Optical clocks for a new definition of the second

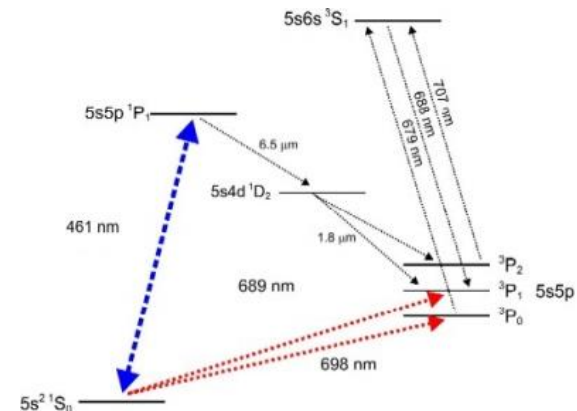
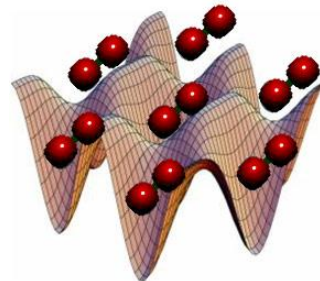
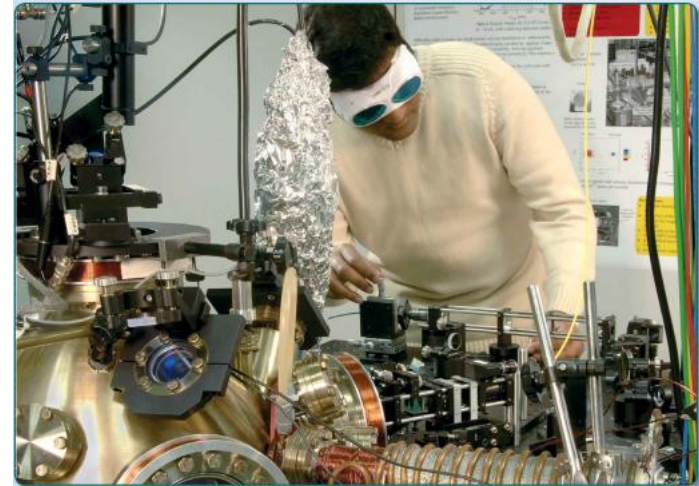
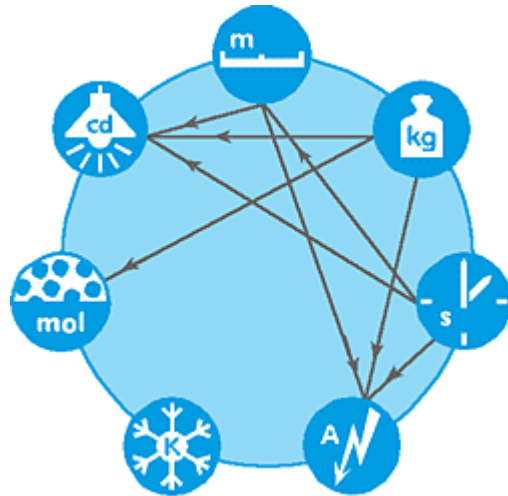

frequency stability approaching
0.000000000000000001
(3 sec in 1 billion years)

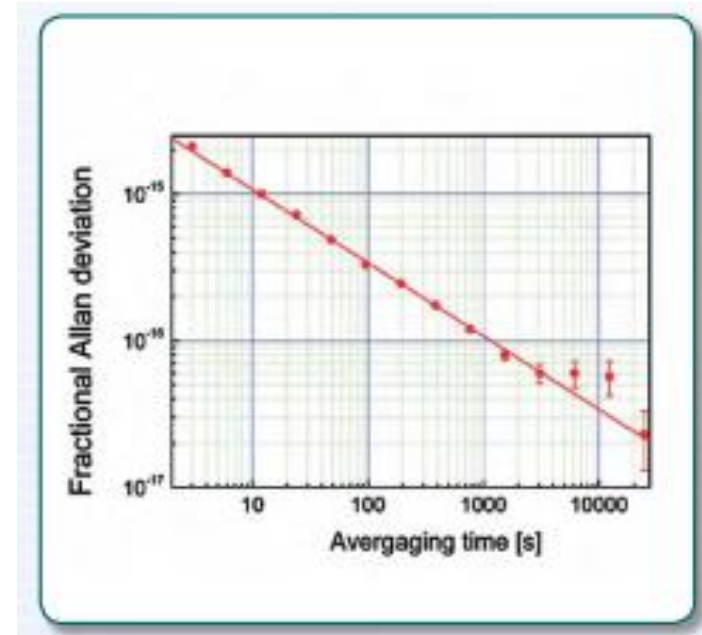

Space project 1: ACES/PHARAO

due to commence in 2014

- mapping the Earth's gravitational field using atomic clocks as sensors of the gravitational redshift

Space project 2: STE-QUEST

due after 2020

- violations in relativistic redshift?

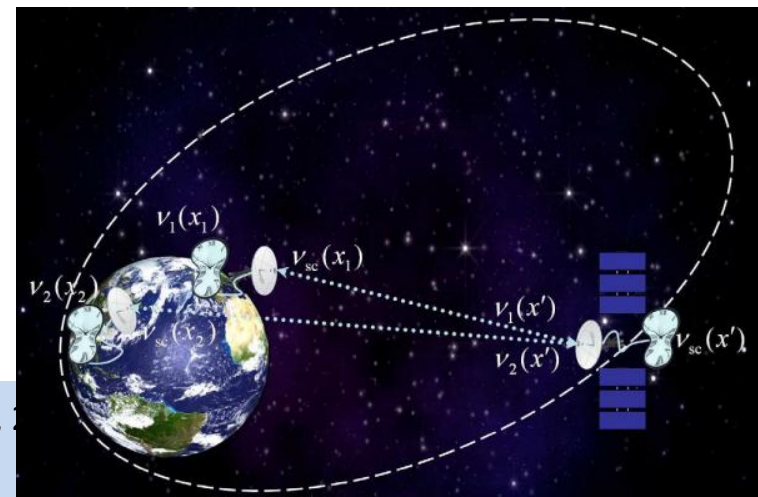

„Our institute would never have been able to do this alone“

„iMERAplus enabled us to enter a new field“

Recognizing what our partners do
we decided to stop this activities
and focus on another area“

„Our staff has learnt to execute a project efficiently“

„We have learnt so much from our partners“

„We plan a follow-up project“

EMRP Article 169/185

Metrology for ...

2009	Energy	projects running
2010	Environment	projects running
	Metrology for Industry	
2011	Health	contracting soon
	SI broader scope	
	New Technologies	
2012	Metrology for Industry	strategic preparation
	SI broader scope	
	Open excellence call	
2013	Energy	strategic preparation
	Environment	

EMRP ERAnet-plus

Metrology for ...

2007	Measurement units	all 21 projects ended 2011
	Health	
	Length	
	Electromagnetism	

Thank you for your attention!

See the posters,
discuss with EURAMET representatives,
enjoy the buffet reception

secure measurements
and reference data

do/underpin
basic science

drive innovation

do you get
what you
pay for?

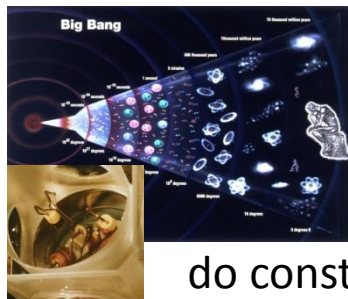

do constants
of nature drift with time?



efficiency?
quality control
in production?



safely below
radiation limits?

data quality for
policy making
sufficient?

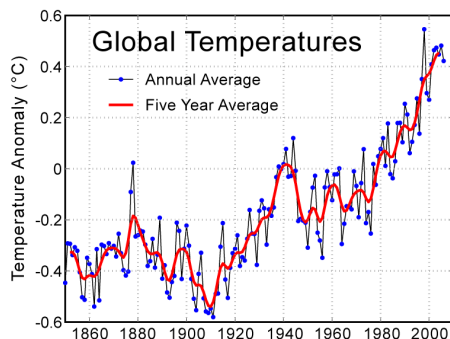

precise enough
to be
competitive?

