

**Supplementary Comparison EUROMET.EM-S23
EURAMET PROJECT No 815**

Bilateral Comparison of Inductive Voltage Divider

FINAL REPORT

Proposer/coordinator Florin Mirea (INM, pilot laboratory)
Erik Dierikx (VSL)

July 2010

National Institute of Metrology
11 Vitan-Birzesti Road, sector 4
042122, BUCHAREST
ROMANIA

VSL
Thijssseweg 11
NL-2629 JA, DELFT
The NETHERLANDS

Abstract

This report presents the results of a bilateral comparison of the measurements on an inductive voltage divider within the framework of EURAMET. The aim of the project is a comparison of AC voltage ratio measurements between INM, Romania, and VSL, the Netherlands.

Measurements of the decade ratios 0.1, 0.2, ... 0.9 were performed at the following frequencies and voltages: 55 Hz/5 V, 400 Hz/10 V and 1 kHz/10 V.

The agreement between the results from both laboratories is well within 0.2×10^{-6} V/V for the in-phase ratio deviations and within 1.0×10^{-6} V/V for the quadrature deviations respectively.

Table of content

1. Introduction	3
2. Participants	3
3. Travelling standard.....	4
4. Measurements	5
5. Results.....	6
5.1. VSL Measurement results	6
5.2. INM measurement results	8
6. Degree of equivalence.....	10
Annex 1. Measurement method of the participants.....	17
A1.1. VSL Bootstrapping absolute method	17
A1.2. INM Absolute method of reference voltage.....	19
Annex 2. Uncertainty budgets of the participants	21
A2.1. VSL Uncertainty budget.....	21
A2.2. INM Uncertainty budget	27
Annex 3. Technical protocol	31

Comparison of Alternating Voltage Ratio using an Inductive Voltage Divider

1. Introduction

The aim of this project is comparison of the national standards of AC voltage ratio of INM and VSL at 55 Hz/5 V, 400 Hz/10 V and 1 000 Hz/10 V by means of inductive voltage divider with $U = 0.2 \times 10^{-6}$ ($k=2$). The pilot laboratory is INM Bucharest and the measurements were performed first in Delft and repeated in Bucharest.

The main targets of the comparison are:

- to demonstrate equivalence of metrological practice
- to contribute to acceptance of INM in EURAMET
- to confirm the proposed CMC values of INM in the field of AC voltage ratio
- to check the correctness of the calibration results

2. Participants

National Institute of Metrology (INM), Romania

National Institute of Metrology
11 Vitan-Birzesti Road, sector 4
zip code 042122, BUCHAREST
ROMANIA

Contact person: Florin Mirea
florin@inm.ro
+40213345060 ext. 170

VSL, Dutch Metrology Institute, The Netherlands

(Before April 1st, 2009, VSL was known as Nederlands Meetinstituut, Van Swinden
Laboratorium, NMi VSL)

VSL
Thijsseweg 11
NL-2629 JA, DELFT
The NETHERLANDS

Contact person: Erik Dierikx
edierikx@vsl.nl
+31 15 269 1688

The measurements were performed first in Delft from 15 to 17 November 2004 and repeated in Bucharest, from 22 to 26 November 2004 using the usual measurement procedures of the participants.

3. Travelling standard

The travelling standard was an autotransformer, having a fixed set of ten taps. The device was provided by the Romanian laboratory. It is a self-constructed instrument of type U.1.d.0-10×0,1 serial number 8201. The device has a fixed ratio magnetizing winding and a secondary decade winding with nominal values of the ratio $k = 0.1 \cdot i$ where $i = 1$ to 10. The maximum input voltage must not exceed the value deduced from the formula:

$$U [\text{V}] = 0.15 \times f [\text{Hz}].$$

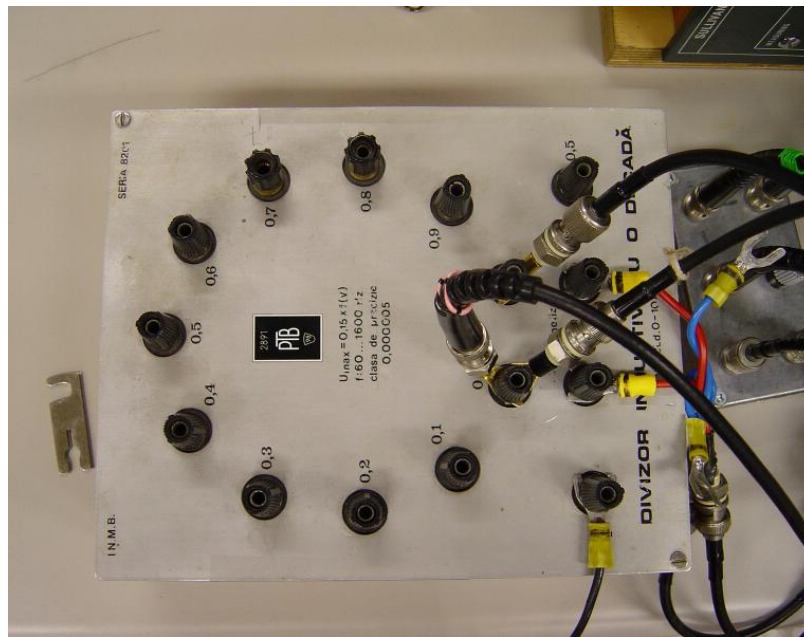

Figure 1. Travelling standard

4. Measurements

The divider should be energized with identical sinusoidal alternating voltages applied in parallel to the ports marked “pre-magnetize”, 0 and 1.0. These voltages must be sufficiently stable in both frequency and amplitude for a single value, obtained from traceable calibrated instruments, to be given for each set of results. The amplitude values should be expressed in RMS [root-mean-square] volts, frequencies in Hz.

It is recommended that the travelling standard be energized and given a minimum 2 hours to reach equilibrium with the laboratory environment before measurements are made.

The temperature of the case of the travelling standard must be measured using traceable calibrated instruments with an uncertainty of ± 0.5 °C or better.

The travelling standard is intended to be calibrated in an upright and leveled condition.

Mandatory Measurements

Table 1

Frequency Hz	Input Volts V (rms)	Ratios
55	10	0.1, 0.2, 0.3, 0.4, 0.5, 0.6, 0.7, 0.8, 0.9, 1.0

Table 2

Frequency Hz	Input Volts V (rms)	Ratios
400	10	0.1, 0.2, 0.3, 0.4, 0.5, 0.6, 0.7, 0.8, 0.9, 1.0

Table 3

Frequency Hz	Input Volts V (rms)	Ratios
1000	10	0.1, 0.2, 0.3, 0.4, 0.5, 0.6, 0.7, 0.8, 0.9, 1.0

5. Results

The participants should be able to measure both orthogonal components of the alternating voltage ratio of the traveling standard with an expanded uncertainty ($k=2$) of less than 200×10^{-9} of the input.

The participants must be able to conduct the measurements in equilibrium conditions at a temperature of either $22 \pm 1 \text{ }^\circ\text{C}$ or $23 \pm 1 \text{ }^\circ\text{C}$ in air; relative humidity $40 \% \pm 10 \%$ and frequencies uncertainty $U = 0.3\%$.

5.1. VSL Measurement results

The measurement conditions and input signals are given in Table 4 and Table 5. The results of the ratio measurements are given in Table 6 to 8.

Table 4. Measurement conditions

	Average	Uncertainty	Maximum	Minimum
Temperature	22.0 °C	1.0 °C	22.3 °C	21.4 °C
Relative humidity	40 %	5 %	39 %	42 %

Table 5. Input signals

	55 Hz	400 Hz	1000 Hz
Voltage	5.00 V	10.0 V	10.0 V
uncertainty ($k = 2$)	0.25 V	0.5 V	0.5 V
Frequency	55.00 Hz	403.0 Hz	1 003.0 Hz
uncertainty ($k = 2$)	0.06 Hz	0.4 Hz	1.0 Hz

Table 6. Measurement results at 55 Hz

Nominal ratio	In-phase V/V	Expanded Uncertainty 10^{-6} V/V	Quadrature V/V	Expanded Uncertainty 10^{-6} V/V
0.1	0.099 999 991	0.069	0.000 000 013	0.574
0.2	0.199 999 982	0.091	0.000 000 019	0.773
0.3	0.299 999 957	0.109	0.000 000 010	0.932
0.4	0.399 999 949	0.125	0.000 000 015	1.067
0.5	0.499 999 946	0.139	0.000 000 048	1.189
0.6	0.599 999 959	0.125	0.000 000 001	1.067
0.7	0.699 999 955	0.109	-0.000 000 036	0.932
0.8	0.799 999 960	0.091	-0.000 000 039	0.773
0.9	0.899 999 958	0.069	-0.000 000 014	0.574

Table 7. Measurement results at 400 Hz

Nominal ratio	In-phase V/V	Expanded Uncertainty 10^{-6} V/V	Quadrature V/V	Expanded Uncertainty 10^{-6} V/V
0.1	0.099999997	0.033	0.000 000 072	0.195
0.2	0.199999998	0.045	0.000 000 073	0.270
0.3	0.299999996	0.054	0.000 000 013	0.331
0.4	0.399999989	0.062	-0.000 000 070	0.384
0.5	0.499999983	0.069	-0.000 000 163	0.433
0.6	0.599999985	0.062	-0.000 000 238	0.384
0.7	0.699999992	0.054	-0.000 000 272	0.331
0.8	0.800000000	0.045	-0.000 000 250	0.270
0.9	0.900000000	0.033	-0.000 000 164	0.195

Table 8. Measurement results at 1 kHz

Nominal ratio	In-phase V/V	Expanded Uncertainty 10^{-6} V/V	Quadrature V/V	Expanded Uncertainty 10^{-6} V/V
0.1	0.100 000 001	0.018	0.000 000 143	0.146
0.2	0.200 000 009	0.025	0.000 000 112	0.201
0.3	0.300 000 010	0.030	-0.000 000 044	0.244
0.4	0.400 000 016	0.036	-0.000 000 271	0.281
0.5	0.500 000 013	0.041	-0.000 000 514	0.313
0.6	0.600 000 014	0.036	-0.000 000 703	0.281
0.7	0.700 000 015	0.030	-0.000 000 791	0.244
0.8	0.800 000 012	0.025	-0.000 000 704	0.201
0.9	0.900 000 006	0.018	-0.000 000 446	0.146

5.2. INM measurement results

The measurement conditions and input signals are given in Table 9 and Table 10. The results of the ratio measurements are given in Table 11 to 13.

Table 9. Measurement conditions

	Average	Uncertainty	Maximum	Minimum
Temperature	21.0 °C	1.0 °C	20.8 °C	21.6 °C
Relative humidity	35 %	5 %	38 %	40 %

Table 10. Input signals

	55 Hz	400 Hz	1000 Hz
Voltage	5.00 V	10.0 V	10.0 V
uncertainty ($k = 2$)	0.3 V	0.5 V	0.5 V
Frequency	55.00 Hz	405.0 Hz	1 003.0 Hz
uncertainty ($k = 2$)	0.10 Hz	0.8 Hz	1.2 Hz

Table 11. Measurement results at 55 Hz

Nominal ratio	In-phase V/V	Expanded Uncertainty 10^{-6} V/V	Quadrature V/V	Expanded Uncertainty 10^{-6} V/V
0.1	0.099999984	0.121	0.000000001	0.346
0.2	0.199999980	0.123	0.000000006	0.346
0.3	0.299999969	0.132	-0.000000008	0.346
0.4	0.399999970	0.131	-0.000000015	0.346
0.5	0.499999981	0.122	-0.000000023	0.346
0.6	0.600000007	0.117	-0.000000024	0.346
0.7	0.700000023	0.125	-0.000000029	0.346
0.8	0.800000026	0.127	-0.000000026	0.346
0.9	0.900000012	0.119	-0.000000014	0.346
1.0	1.000000000	0.116	0.000000001	0.346

Table 12. Measurement results at 400 Hz

Nominal ratio	In-phase V/V	Expanded Uncertainty 10^{-6} V/V	Quadrature V/V	Expanded Uncertainty 10^{-6} V/V
0.1	0.099999990	0.116	0.000000059	0.346
0.2	0.199999990	0.116	0.000000069	0.346
0.3	0.299999986	0.117	0.000000042	0.346
0.4	0.399999986	0.116	-0.000000008	0.346
0.5	0.499999989	0.116	-0.000000076	0.346
0.6	0.599999995	0.116	-0.000000145	0.346
0.7	0.700000004	0.116	-0.000000179	0.346
0.8	0.800000005	0.116	-0.000000173	0.346
0.9	0.900000004	0.116	-0.000000110	0.346
1.0	1.000000000	0.116	0.000000000	0.346

Table 13 Measurement results at 1 kHz

Nominal ratio	In-phase V/V	Expanded Uncertainty 10^{-6} V/V	Quadrature V/V	Expanded Uncertainty 10^{-6} V/V
0.1	0.100000010	0.116	0.000000126	0.346
0.2	0.200000010	0.116	0.000000151	0.346
0.3	0.300000014	0.117	0.000000070	0.346
0.4	0.400000014	0.116	-0.000000045	0.346
0.5	0.500000011	0.116	-0.000000196	0.346
0.6	0.600000005	0.116	-0.000000331	0.346
0.7	0.699999996	0.116	-0.000000411	0.346
0.8	0.799999995	0.116	-0.000000396	0.346
0.9	0.899999996	0.116	-0.000000259	0.346
1	1.000000000	0.116	0.000000000	0.346

6. Degree of equivalence

The degree of equivalence, D , between the two laboratories is found from the difference of the measurement results, X_i :

$$D = X_{\text{INM}} - X_{\text{VSL}}$$

with an expanded uncertainty:

$$U_D = \sqrt{U_{\text{INM}}^2 + U_{\text{VSL}}^2}$$

It has been assumed that the correlation between the uncertainties U_{INM} and U_{VSL} is negligible.

The level of agreement between the laboratories can also be expressed as a figure of merit E_n :

$$E_n = \frac{|X_{\text{INM}} - X_{\text{VSL}}|}{\sqrt{(U_{\text{INM}}^2 + U_{\text{VSL}}^2)}}$$

Both the degree of equivalence D and the figure of merit E_n are given in Tables 14 to 19. The degrees of equivalence are also shown in Figures 2 to 7.

Table 14. Measurement results at 55 Hz in phase

Nominal ratio	D_{phase} 10^{-6} V/V	$U(D_{\text{phase}})$ 10^{-6} V/V	E_n
0.1	-0.01	0.14	0.05
0.2	0.00	0.15	0.01
0.3	0.01	0.17	0.07
0.4	0.02	0.18	0.12
0.5	0.04	0.18	0.19
0.6	0.05	0.17	0.28
0.7	0.07	0.17	0.41
0.8	0.07	0.16	0.42
0.9	0.05	0.14	0.39

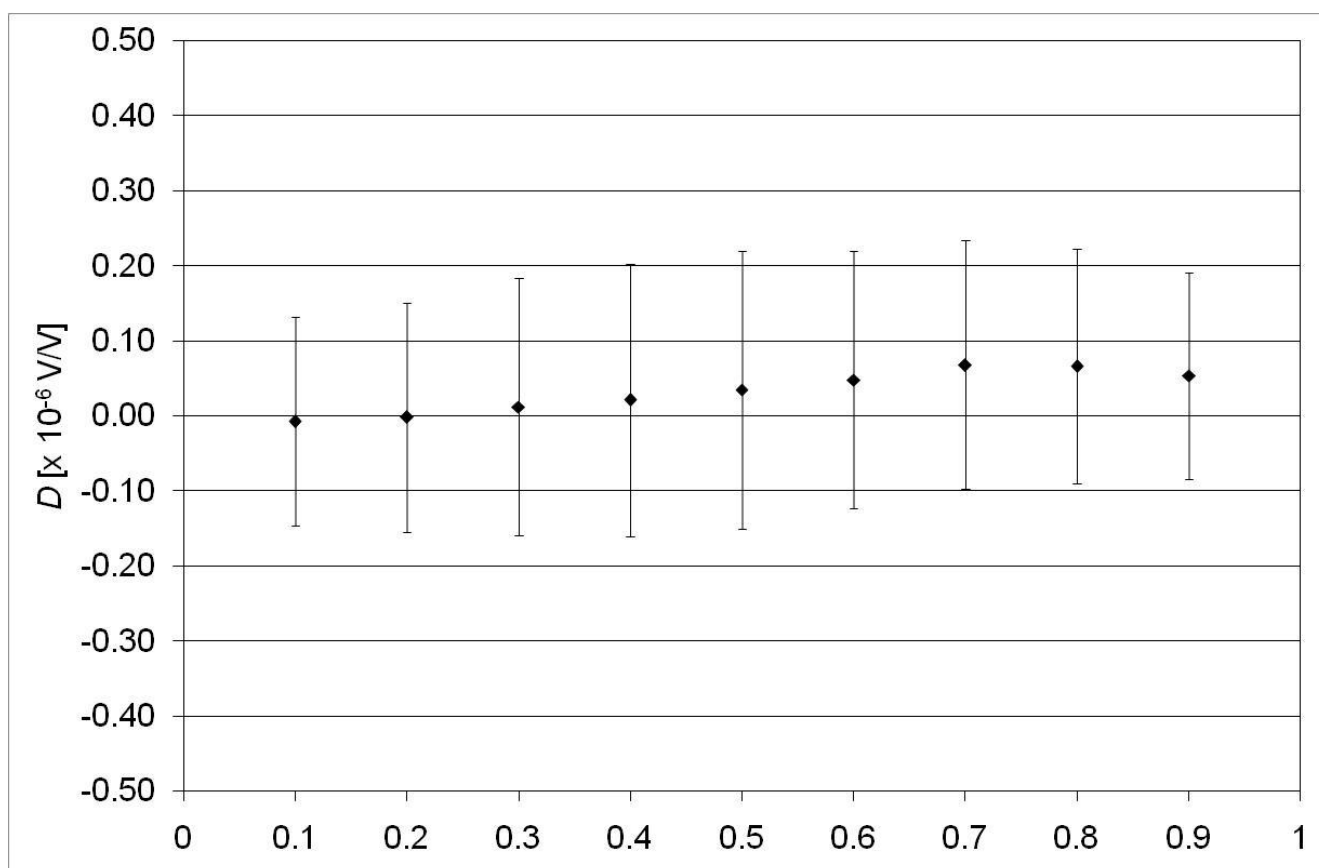

Figure 2. Degrees of equivalence at 55 Hz in phase

Table 15. Measurement results at 55 Hz in quadrature

Nominal ratio	D_{quad} 10^{-6} V/V	$U(D_{\text{quad}})$ 10^{-6} V/V	E_n
0.1	-0.01	0.67	0.02
0.2	-0.01	0.85	0.02
0.3	-0.02	0.99	0.02
0.4	-0.03	1.12	0.03
0.5	-0.07	1.24	0.06
0.6	-0.03	1.12	0.02
0.7	0.01	0.99	0.01
0.8	0.01	0.85	0.02
0.9	0.00	0.67	0.00

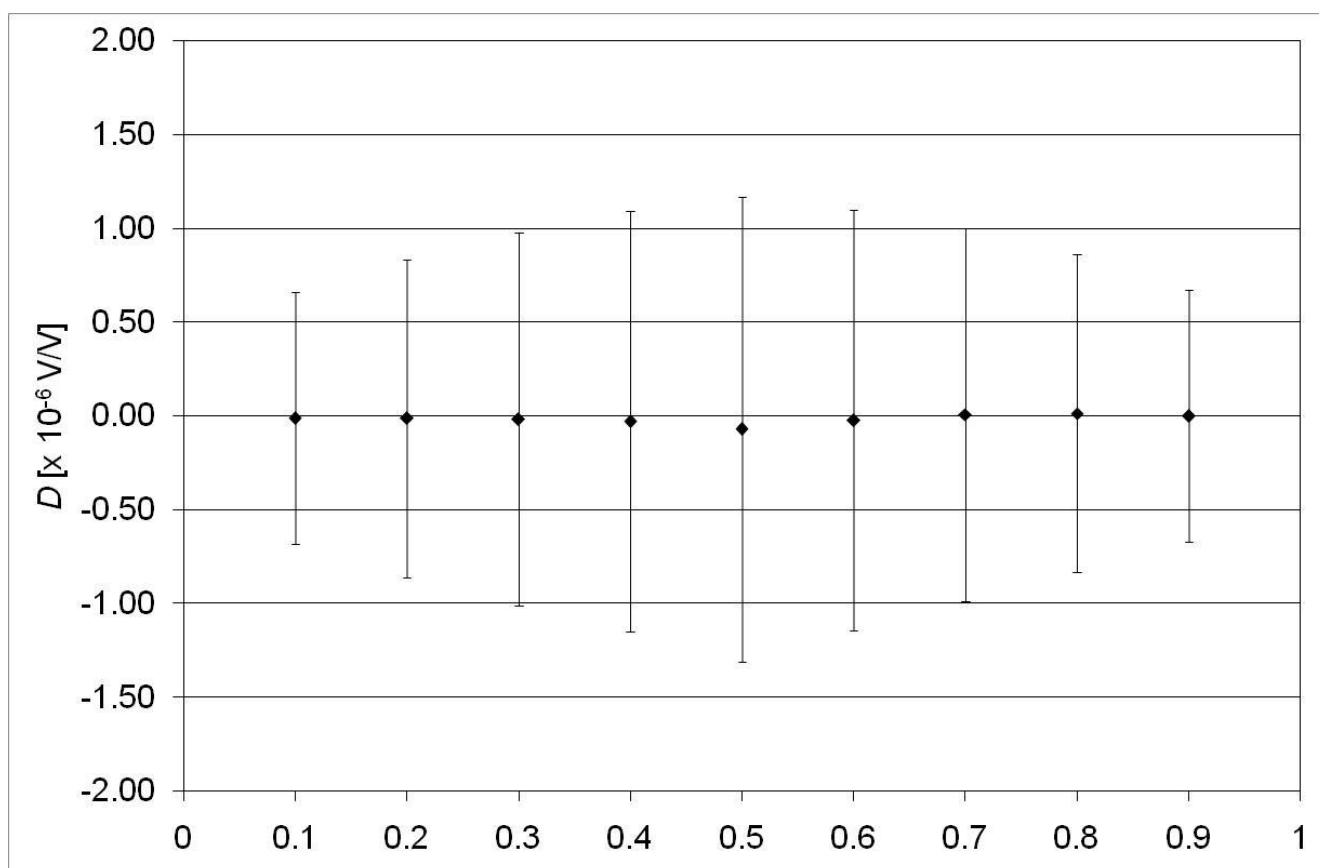

Figure 3. Degrees of equivalence at 55 Hz in quadrature

Table 16. Measurement results at 400 Hz in phase

Nominal ratio	D_{phase} 10^{-6} V/V	$U(D_{\text{phase}})$ 10^{-6} V/V	E_n
0.1	-0.01	0.12	0.06
0.2	-0.01	0.12	0.06
0.3	-0.01	0.13	0.08
0.4	0.00	0.13	0.02
0.5	0.01	0.13	0.04
0.6	0.01	0.13	0.08
0.7	0.01	0.13	0.09
0.8	0.00	0.12	0.04
0.9	0.00	0.12	0.03

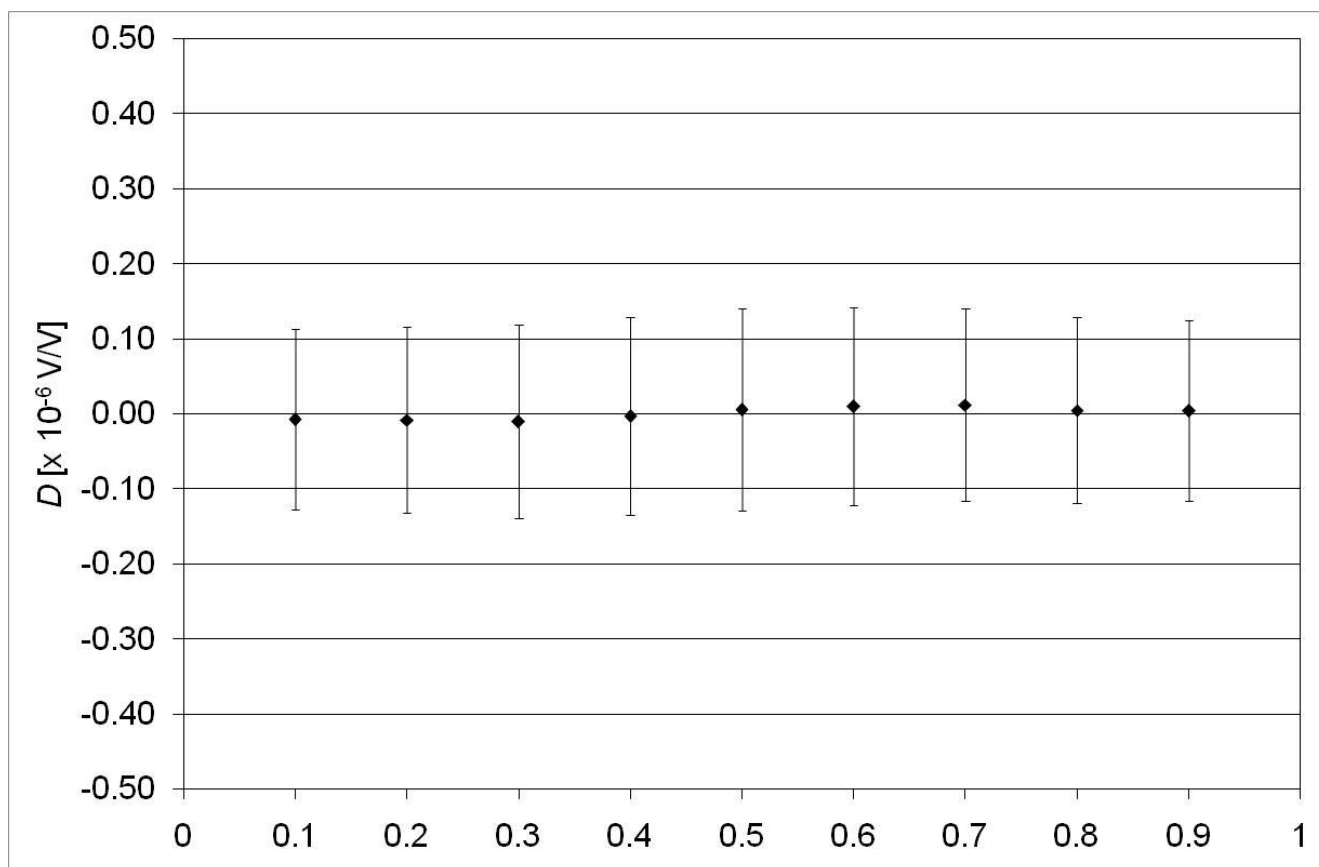

Figure 4. Degrees of equivalence at 400 Hz in phase

Table 17. Measurement results at 400 Hz in quadrature

Nominal ratio	D_{quad} 10^{-6} V/V	$U(D_{\text{quad}})$ 10^{-6} V/V	E_n
0.1	-0.01	0.40	0.03
0.2	0.00	0.44	0.01
0.3	0.03	0.48	0.06
0.4	0.06	0.52	0.12
0.5	0.09	0.55	0.16
0.6	0.09	0.52	0.18
0.7	0.09	0.48	0.19
0.8	0.08	0.44	0.18
0.9	0.05	0.40	0.14

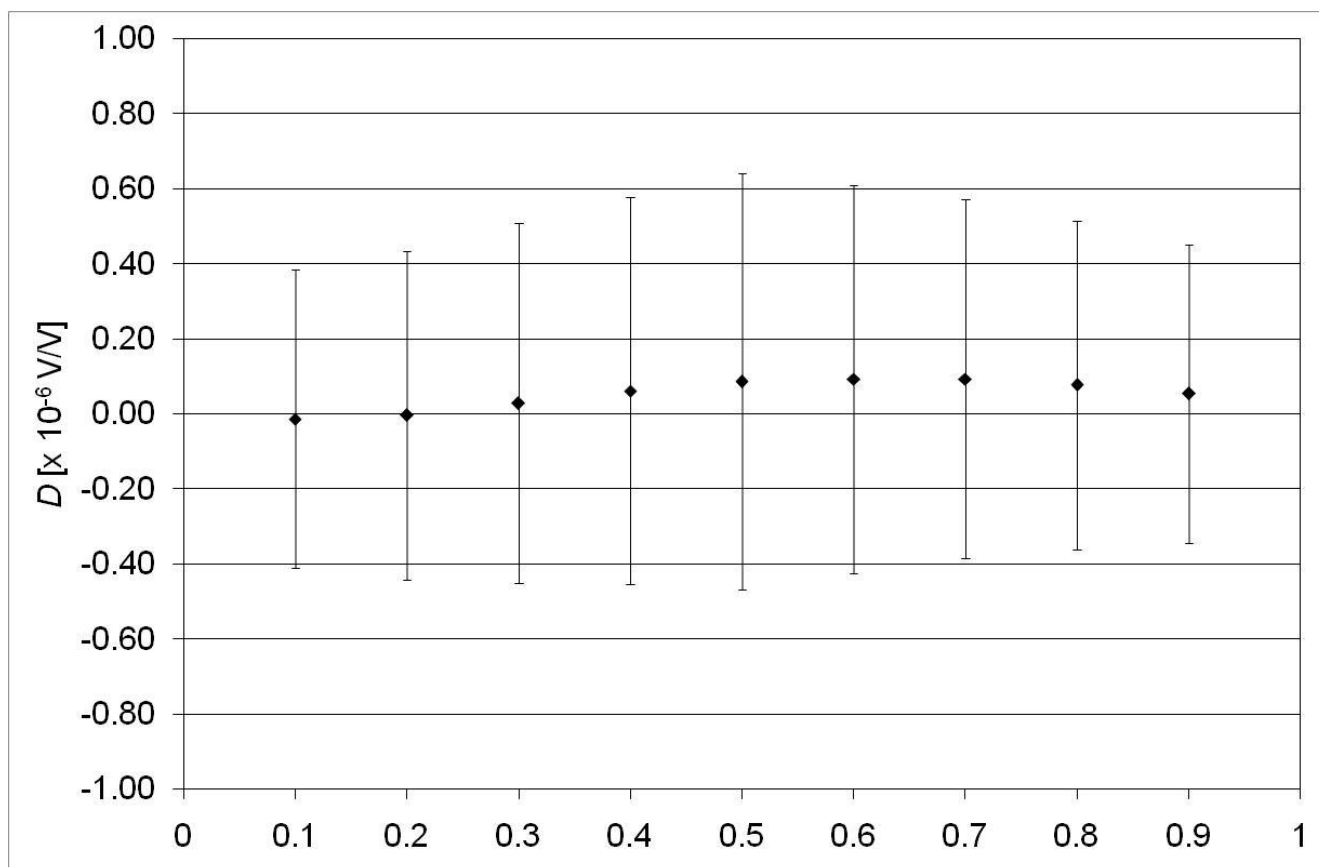

Figure 5. Degrees of equivalence at 400 Hz in quadrature

Table 18. Measurement results at 1 kHz in phase

Nominal ratio	D_{phase} 10^{-6} V/V	$U(D_{\text{phase}})$ 10^{-6} V/V	E_n
0.1	0.01	0.12	0.08
0.2	0.00	0.12	0.01
0.3	0.00	0.12	0.03
0.4	0.00	0.12	0.02
0.5	0.00	0.12	0.02
0.6	-0.01	0.12	0.07
0.7	-0.02	0.12	0.16
0.8	-0.02	0.12	0.14
0.9	-0.01	0.12	0.09

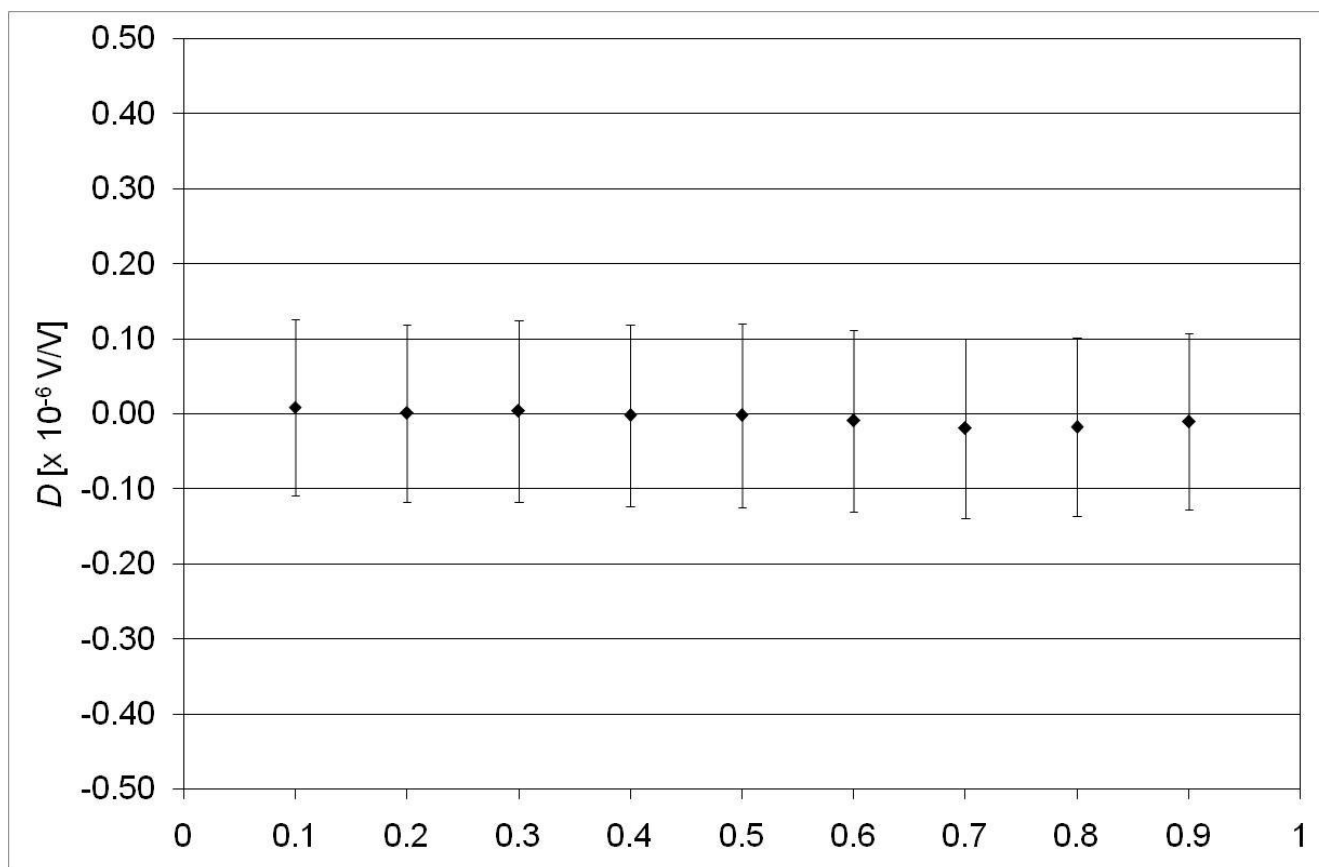

Figure 6. Degrees of equivalence at 1 kHz in phase

Table 19. Measurement results at 1 kHz in quadrature

Nominal ratio	D_{quad} 10^{-6} V/V	$U(D_{\text{quad}})$ 10^{-6} V/V	E_n
0.1	-0.02	0.38	0.05
0.2	0.04	0.40	0.10
0.3	0.11	0.42	0.27
0.4	0.23	0.45	0.51
0.5	0.32	0.47	0.68
0.6	0.37	0.45	0.83
0.7	0.38	0.42	0.90
0.8	0.31	0.40	0.77
0.9	0.19	0.38	0.50

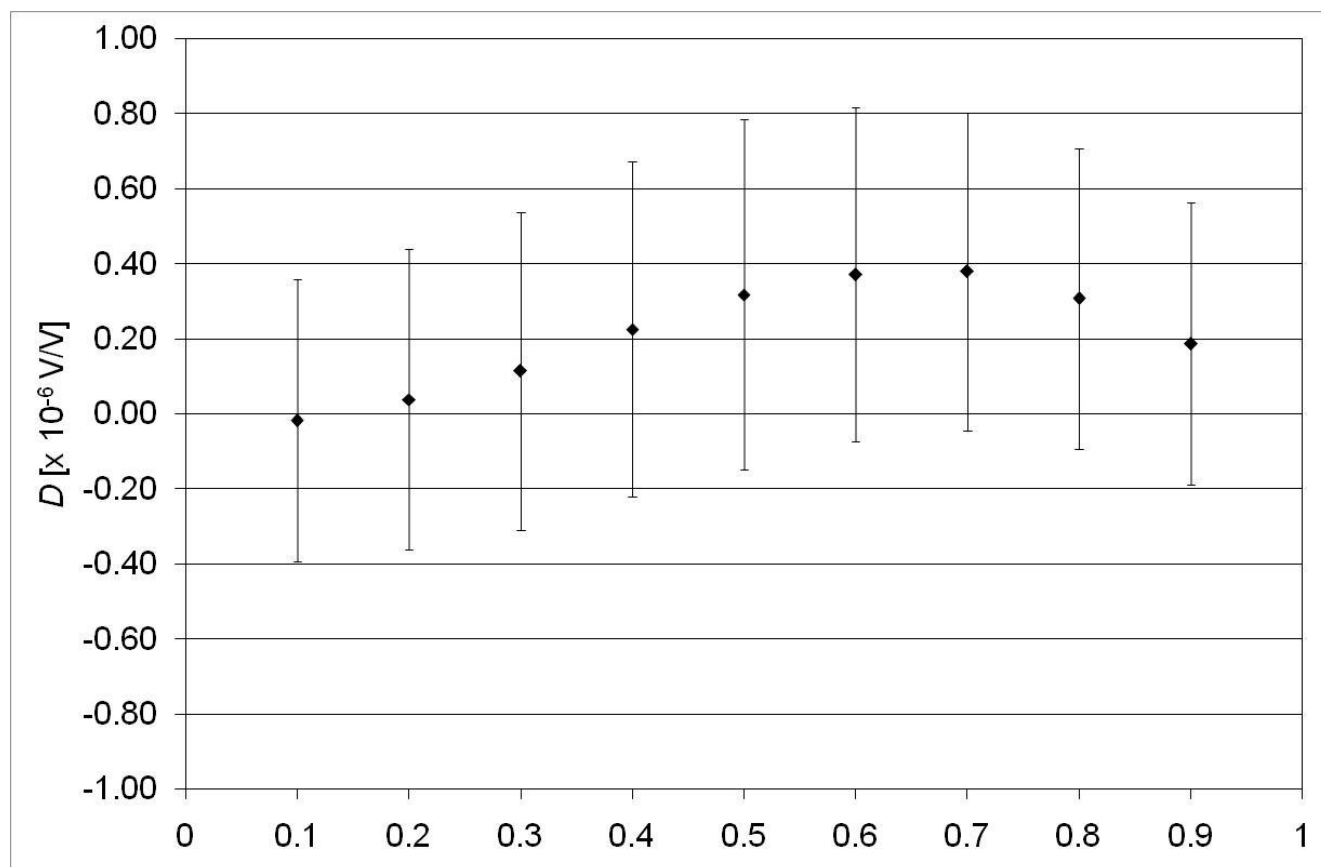

Figure 7. Degrees of equivalence at 1 kHz in quadrature

Annex 1. Measurement method of the participants

A1.1. VSL Bootstrapping absolute method

The voltage ratios of the travelling standard have been determined by a bootstrapping method. An 8-dial inductive voltage divider (i.v.d.) was used as an auxiliary divider. A schematic diagram of the set-up is given in Figure A1.1.

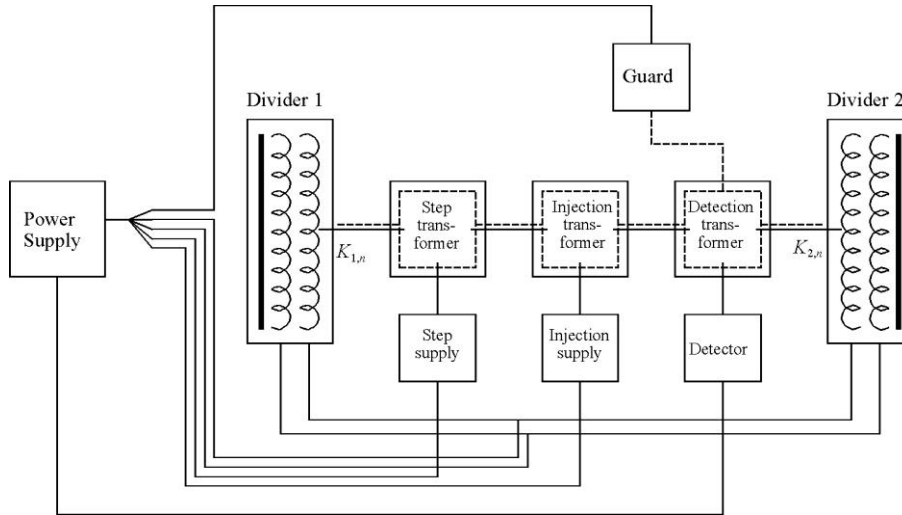

Figure A1.1. Schematic diagram of the measurement set-up

Suppose $U_{1,n}$ ($n = 0.1, 0.2, \dots, 0.9$) are the output ratios of the travelling standard where n is the nominal tap ratio. $U_{2,n}$ ($n = 0.1, 0.2, \dots, 0.9$) are the output ratios of the auxiliary divider with n the nominal dial setting.

The output voltages are given by:

$$V_{x,n} = U_{x,n} \cdot V_{in,x} \quad (\text{A1.1})$$

$V_{in,x}$ are the input voltages for the dividers
 $x = (1, 2)$

The output voltage differences,

$$\Delta V_{i,i} = V_{1,i} - V_{2,i} \quad (\text{A1.2})$$

$i = (0, 0.1, 0.2, \dots, 1.0)$

are measured by means of an injection and detection system. With the injection system an adjustable in-phase and quadrature voltage can be generated to obtain a zero reading on the null-detector.

With an additional step transformer, the voltage differences

$$\Delta V_{(i+0.1),i} = V_{1,(i+0.1)} - V_{2,i} \quad (\text{A1.3})$$

$i = (0, 0.1, 0.2, \dots, 0.9)$

can also be determined.

Note that $\Delta V_{(i+0.1),i}$ consists of two parts:

- an unknown, but fixed part from the step transformer which will be calculated after the measurements;
- a known part which is variable and is measured by the injection system to obtain a zero reading on the null-detector.

It is very important that the output voltage of the step transformer remains the same for all steps i . For a correct measurement of $\Delta V_{i,i}$ and $\Delta V_{(i+0.1),i}$ it is also very important that the injection transformer, the detection transformer and the step transformer are properly guarded to avoid leakage currents.

By definition, for divider 1 (the travelling standard):

$$V_{in,1} = -\sum_{i=0.0}^{0.9} \Delta V_{i,i} + \sum_{i=0.0}^{0.9} \Delta V_{(i+0.1),i} \quad (\text{A1.4})$$

and, for divider 2 (the auxiliary divider):

$$V_{in,2} = -\sum_{i=0.1}^{1.0} \Delta V_{i,i} + \sum_{i=0.1}^{0.9} \Delta V_{(i+0.1),i} \quad (\text{A1.5})$$

Equations (A1.4) and (A1.5) assume that the output taps $U_{x,0,0}$ and $U_{x,1,0}$ have no deviations from nominal so $U_{x,0,0} = 0$ and $U_{x,1,0} = 1$.

From equation (A1.4) or (A1.5) the output voltage of the step transformer can be calculated (assuming that this voltage was constant during the entire measurement). Once the step voltage has been determined, it is easy to calculate the different output voltages $V_{x,n}$ and the corresponding output ratios $U_{x,n}$ for both dividers.

$$V_{1,n} = -\sum_{i=0}^{n-0.1} \Delta V_{i,i} + \sum_{i=0}^{n-0.1} \Delta V_{(i+0.1),i} \quad (\text{A1.6})$$

$$V_{2,n} = -\sum_{i=0.1}^n \Delta V_{i,i} + \sum_{i=0.0}^{n-0.1} \Delta V_{(i+0.1),i} \quad (\text{A1.7})$$

$$U_{x,n} = \frac{V_{x,n}}{V_{in,x}} \quad (\text{A1.8})$$

The ratios $U_{x,n}$ are complex quantities that can be expressed as:

$$U_{x,n} = U_{inp_x,n} + j U_{qua_x,n} \quad (\text{A1.9})$$

where $U_{inp_x,n}$ is the in-phase component of the ratio and $U_{qua_x,n}$ is the quadrature component. In the following sections the expressions "In-phase" and "Quadrature" will be used.

A1.2. INM Absolute method of reference voltage

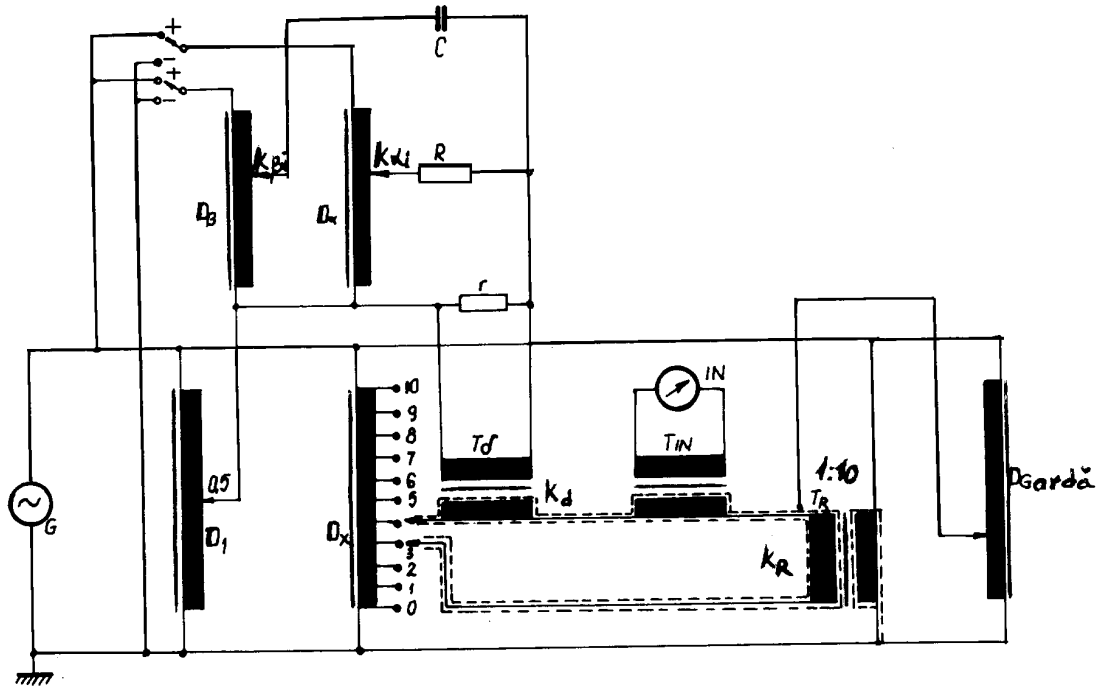

Figure A1.2. Schematics of the INM installation of voltage ratio measurement method by means of reference voltage method

INM, use an absolute method of reference voltage to measure voltage ratio.

The sum of the 10 sections of ratio 0.1 is equal with divider input voltage, or the sum of the errors of the sections is zero. To measure voltage error measurements are performed for each section of the standard divider D_x against the constant voltage of a reference transformer T_r with the nominal ratio 0.1.

The small voltage needed for compensation is injected through T_δ . This voltage is generated by its components the in phase and the in quadrature from a circuit containing the fix 0.5 ratio divider and the 4 decades dividers D_α and D_β . The in phase current with the resistor R and the in quadrature current with the capacitor C compose on the resistor r an adjustable voltage.

To determine the dividers errors is to inject a current which compensate the voltage between reference transformer and the measured voltage. When this goal is achieved the indication of the null indicator is minimal.

For every section of standard divider D_x it can be written:

$$U_i = K_r \times U + u_i \quad (1)$$

where:

- U_i - voltage of the section i of D_x divider;
- U - Input voltage of the D_x from the generator G ;
- $K_r \cong 0.1$ - voltage ratio of the T_r transformer;
- u_i - compensation voltage injected;
- Injected voltage u_i through r , is:

$$u_i = \frac{1}{2} \times K_\delta \times (K_{\alpha i} \times \frac{r}{R} + j \times K_{\beta i} \times r \times \omega \times C) \times U \quad (2)$$

Taking in account that $r \ll R$ and $r \ll 1/C \omega$.

In relation (2) K_δ is the voltage ratio of the injection transformer T_δ and $K_{\alpha i}$ and $K_{\beta i}$ the ratios of the dials D_α and D_β for every section "i".

For every section of the inductive voltage divider, corrections D_x , will result:

- the in phase correction:

$$D_{\alpha} = 0.1 \times \frac{K_{\delta}}{2 \times K_r} \times \frac{r}{R} \times \left(K_{\alpha 1} - \frac{1}{10} \times \sum_{i=1}^{10} K_{\alpha i} \right) \quad (3)$$

- the in quadrature correction:

$$D_{\beta} = 0.1 \times \frac{K_{\delta}}{2 \times K_r} \times r \times C \times \omega \times \left(K_{\beta 1} - \frac{1}{10} \times \sum_{i=1}^{10} K_{\beta i} \right) \quad (4)$$

The numerical values are:

$$K_{\delta} = 0.02;$$

$$K_r = 0.1;$$

$$r/R = r \times C \times \omega = 0.001 ;$$

$$r = 2 \Omega;$$

$$R = 2000 \Omega;$$

Magnitudes of D_{α} and D_{β} will be:

$$D_{\alpha} = 10^{-5} \times \left(K_{\alpha i} - \frac{1}{10} \times \sum_{i=1}^{10} K_{\alpha i} \right) \quad (5)$$

$$D_{\beta} = 10^{-5} \times \left(K_{\beta i} - \frac{1}{10} \times \sum_{i=1}^{10} K_{\beta i} \right) \quad (6)$$

Magnitudes of the most significant number will be 10^{-6} for a 4 digits error.

The reference transformer T_r , was build with respect to certain goals:

- stability of the voltage ratio;
- insensitivity of the voltage ratio from the voltage between secondary winding and ground.

It is a 2 stage transformer built on a double core with high permeability with good stability and small errors.

The guarding divider and the injection dividers are typically inductive voltage dividers built at INM.

- Injection transformer T_{δ} have a ratio of of 1:50.
- Resistors R and r , and capacitor C are standard with a good stability.
- Null indicator IN with adaptation transformer T_{in} ensure a sensitivity about (20 ... 100) nV.
- Entire installation was shielded.

Annex 2. Uncertainty budgets of the participants

A2.1. VSL Uncertainty budget

The calculation of the uncertainty budget for IVD calibrations with the bootstrapping method is rather complicated, due to the fact that the ratio difference measurements are correlated. To gain insight in the uncertainty contributions, first an estimate is made of a single ratio difference measurement. Then, it will be shown how the uncertainty is determined for a complete set of ratio difference measurements in a calibration with the bootstrapping method.

All measurements to determine the ratios of the dividers are performed by null detection. Small voltage differences are compensated with a voltage injection system as shown in Figure A2.1. The uncertainty in the ratios to be measured is mainly caused by uncertainties in this injection system.

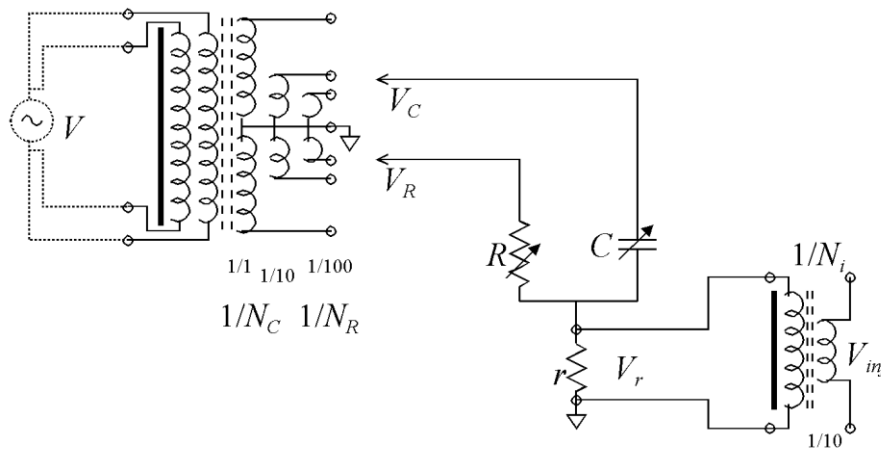

Figure A2.1. Schematic diagram of the voltage injection system

r is a resistor with a value of 0.200Ω .

R is decade resistor which is used between $100 \text{ k}\Omega$ and $1.1111 \text{ M}\Omega$

C_R is the small parasitic capacitance in parallel with R .

V_R is the supply voltage for R which is obtained from a transformer

$V_R = V / N_R$, where N_R is 1, 10 or 100 (V_R can be positive or negative).

C is a decade capacitor which is used between 50 pF and 100 nF

G_C or $1/R_C$ is the parallel conductance of the capacitor.

V_C is the supply voltage for the capacitor.

$V_C = V / N_C$, where N_C is chosen to be 10 (V_C can be positive or negative).

V_r is the voltage across r and is also the input voltage for the 10:1 injection transformer, $N_i=10$.

V_{inj} is the output of the transformer and is the final injection voltage.

The injection voltage is found from the following equations:

$$V_{inj} = (\alpha + j\beta) \cdot V$$

where:

$$\alpha = \frac{r}{N_i \cdot N_R \cdot R} \quad (\text{A2.1})$$

$$\beta = \frac{\omega r C}{N_i \cdot N_C} \quad (\text{A2.2})$$

And $\omega = 2 \pi f$; f is the measurement frequency.

In-phase injection at 1 kHz:

The resistance r is determined before the measurements. The uncertainty in r is 1 m Ω ($k=1$). R is a decade resistor that has been calibrated. The resistor is used in the range from 100 k Ω to 1 M Ω . The deviations from nominal are less than 0.04 %. The accuracy to which the resistance can be adjusted is dominated by the reading of the detector. Changes of less than 0.5 k Ω can hardly be seen within the noise of the detector.

N_R is the transformer ratio which determines the voltage that is applied to the resistance R . The ratio can be set to 1, 10 or 100. The relative uncertainty in this ratio, including loading effects, is estimated to be less than $1 \cdot 10^{-5}$.

N_i is the transformer ratio of the injection transformer. The ratio is fixed at 10:1. The relative uncertainty in N_i is estimated to be less than $1 \cdot 10^{-5}$.

Quantity X_i	Estimate x_i	Standard Uncertainty $u(x_i)$	Sensitivity coefficient c_i	Contribution (abs.) $u_i(y)$
r	0.200 Ω	0.001 Ω	$1 \cdot 10^{-6} \Omega^{-1}$	$0.1 \cdot 10^{-8} \text{ V/V}$
R	100 k Ω - 1 M Ω	$4 \cdot 10^{-4} \cdot R + 1 \text{ k}\Omega$	$2 \cdot 10^{-7} \Omega^{-1}$	$0.2 \cdot 10^{-8} \text{ V/V}$
N_R	1, 10, 100	$< 1 \cdot 10^{-5}$ (rel.)	$2 \cdot 10^{-7}$	$2 \cdot 10^{-12} \text{ V/V}$
N_i	10	$< 1 \cdot 10^{-5}$ (rel.)	$2 \cdot 10^{-8}$	$2 \cdot 10^{-12} \text{ V/V}$
α	$2.00 \cdot 10^{-7} \text{ V/V}$		$k = 1$	$0.22 \cdot 10^{-8} \text{ V/V}$

Quadrature injection at 1 kHz:

For r see remark at in-phase injection above.

C is a decade capacitor that has been calibrated. The capacitor is used in the range from 10 pF to 100 nF. The deviations from nominal are less than $2 \cdot 10^{-4}$. When repeated observations are taken into account, the accuracy of the settings on the decade capacitor is ± 0.5 nF.

N_C is the transformer ratio which determines the voltage that is applied to C . N_C is always set to 10. The relative uncertainty in this ratio is estimated to be $1 \cdot 10^{-5}$.

N_i see in-phase injection above.

The uncertainty in ω is determined from the frequency f which has been measured with a multimeter. The uncertainty is about 0.5 %. (This is not a critical parameter.)

Another contribution in the quadrature uncertainty is assigned to capacitive leakage currents through the detector, which result from improper guarding of the detector circuit. Extensive experiments on the measurement setup have shown that this contribution can be estimated to be less the $0.63 \cdot 10^{-8}$ in the measurement reading.

Quantity X_i	Estimate x_i	Standard Uncertainty $u(x_i)$	Sensitivity Coefficient c_i	Contribution (abs.) $u_i(y)$
r	0.200 Ω	0.001 Ω	$6.3 \cdot 10^{-6} \Omega^{-1}$	$0.63 \cdot 10^{-8} \text{ V/V}$
C	10 pF - 100 nF	$2 \cdot 10^{-4} \cdot C \pm 0.5 \text{ nF}$	12.6 F^{-1}	$0.63 \cdot 10^{-8} \text{ V/V}$
N_C	10	$< 1 \cdot 10^{-5}$ (rel.)	$1.26 \cdot 10^{-7}$	$1.26 \cdot 10^{-11} \text{ V/V}$
N_i	10	$< 1 \cdot 10^{-5}$ (rel.)	$1.26 \cdot 10^{-7}$	$1.26 \cdot 10^{-11} \text{ V/V}$
ω	6283.1 rad/s	0.3 rad/s	$2 \cdot 10^{-10} \text{ s/rad}$	$0.6 \cdot 10^{-10} \text{ V/V}$
Guarding	0	$0.63 \cdot 10^{-8}$	1	$0.63 \cdot 10^{-8} \text{ V/V}$
β	$1.26 \cdot 10^{-6} \text{ V/V}$		$k = 1$	$1.09 \cdot 10^{-8} \text{ V/V}$

With the estimated uncertainties in the individual α and β measurements, values can be calculated for the uncertainties in the in-phase and quadrature deviations from the nominal divider ratios.

The equations as given above have been numerically worked out in the tables on the following pages. Only the tables for output ratio 0.5 are given. The uncertainty tables for other output taps are quite similar. The differences are in the sensitivity coefficients, uncertainty contributions and degrees of freedom.

It can be shown that by good approximation:

$$u(a_{0.1}) = u(a_{0.9}) \quad u(b_{0.1}) = u(b_{0.9})$$

$$u(a_{0.2}) = u(a_{0.8}) \quad u(b_{0.2}) = u(b_{0.8})$$

$$u(a_{0.3}) = u(a_{0.7}) \quad u(b_{0.3}) = u(b_{0.7})$$

$$u(a_{0.4}) = u(a_{0.6}) \quad u(b_{0.4}) = u(b_{0.6})$$

(Only the standard uncertainties in the terms may be slightly different, but in practice this effect is negligible.)

Output tap 0.5 Freq. 55 Hz In-phase							
Quantity	Estimate	Uncertainty	Distribution	Standard uncertainty	Sensitivity	Contribution	Degrees of freedom
X_i	x_i			$u(x_i)$	c_i	$u_i(y)$	
r	0.2 Ω	0.001 Ω	normal	0.001 Ω	9.99E-06 Ω^{-1}	9.99E-09 V/V	10
N_R	10 V/V	1.00E-05	rectangular	5.77E-06	-2.00E-06	-1.15E-11 V/V	100
N_i	10 V/V	1.00E-05	rectangular	5.77E-06	-2.00E-06	-1.15E-11 V/V	100
R_{2n}	10 k Ω	2 k Ω	rectangular	1.155 k Ω	5.69E-11 Ω^{-1}	6.57E-08 V/V	100
R_{20}	10 k Ω	2 k Ω	rectangular	1.155 k Ω	-6.32E-12 Ω^{-1}	-7.30E-09 V/V	100
δa_C	0 V/V	5.00E-09 V/V	rectangular	2.89E-09 V/V	3.16	9.13E-09 V/V	100
δa_s	0 V/V	5.00E-09 V/V	rectangular	2.89E-09 V/V	2.24	6.45E-09 V/V	100
$s(a)$	0 V/V	1.00E-08 V/V	normal	1.00E-08 V/V	1.00	1.00E-08 V/V	2
					$k = 1$	6.85E-08 V/V	115
					$k = 2.02$	1.39E-07 V/V	

Output tap 0.5 Freq. 55 Hz Quadrature							
Quantity	Estimate	Uncertainty	Distribution	Standard uncertainty	Sensitivity	Contribution	Degrees of freedom
X_i	x_i			$u(x_i)$	c_i	$u_i(y)$	
r	0.2 Ω	0.001 Ω	normal	0.001 Ω	7.89E-05 Ω^{-1}	7.89E-08 V/V	10
ω	345.5752 rad/s	5.00E-03	normal	0.005	1.58E-05	7.89E-08 V/V	100
N_C	1 V/V	1.00E-05	rectangular	5.77E-06	-1.58E-05	-9.12E-11 V/V	100
N_i	10 V/V	1.00E-05	rectangular	5.77E-06	-1.58E-05	-9.12E-11 V/V	100
C_{2n}	1000 nF	50 nF	rectangular	28.868 nF	19.67 F $^{-1}$	5.68E-07 V/V	100
C_{20}	1000 nF	50 nF	rectangular	28.868 nF	-2.19 F $^{-1}$	-6.31E-08 V/V	100
δb_s	0 V/V	5.00E-08 V/V	rectangular	2.89E-08 V/V	2.24	6.45E-08 V/V	100
δb_g	0 V/V	5.00E-08 V/V	rectangular	2.89E-08 V/V	3.16	9.13E-08 V/V	100
$s(b)$	0 V/V	2.20E-08 V/V	normal	2.20E-08 V/V	1	2.20E-08 V/V	2
					$k = 1$	5.88E-07 V/V	114
					$k = 2.02$	1.19E-06 V/V	

Output tap 0.5 Freq. 400 Hz In-phase							
Quantity	Estimate	Uncertainty	Distribution	Standard uncertainty	Sensitivity	Contribution	Degrees of freedom
X_i	x_i			$u(x_i)$	c_i	$u_i(y)$	
r	0.2 Ω	0.001 Ω	normal	0.001 Ω	6.24E-06 Ω^{-1}	6.24E-09 V/V	10
N_R	10 V/V	1.00E-05	rectangular	5.77E-06	-1.25E-06	-7.21E-12 V/V	100
N_i	10 V/V	1.00E-05	rectangular	5.77E-06	-1.25E-06	-7.21E-12 V/V	100
R_{2n}	10 k Ω	1 k Ω	rectangular	0.577 k Ω	5.6921E-11 Ω^{-1}	3.29E-08 V/V	100
R_{20}	10 k Ω	1 k Ω	rectangular	0.577 k Ω	-6.325E-12 Ω^{-1}	-3.65E-09 V/V	100
δa_C	0 V/V	1.00E-09 V/V	rectangular	5.77E-10 V/V	3.16	1.83E-09 V/V	100
δa_s	0 V/V	1.00E-09 V/V	rectangular	5.77E-10 V/V	2.24	1.29E-09 V/V	100
dev	0 V/V	6.00E-09 V/V	normal	6.00E-09 V/V	1.00	6.00E-09 V/V	2
					$k = 1$	3.43E-08 V/V	110
					$k = 2.02$	6.93E-08 V/V	

Output tap 0.5 Freq. 400 Hz Quadrature							
Quantity	Estimate	Uncertainty	Distribution	Standard uncertainty	Sensitivity	Contribution	Degrees of freedom
X_i	x_i			$u(x_i)$	c_i	$u_i(y)$	
r	0.2 Ω	0.001 Ω	normal	0.001 Ω	-7.55E-05 Ω^{-1}	-7.55E-08 V/V	10
ω	2513.274 rad/s	5.00E-03	normal	0.005	-1.51E-05	-7.55E-08 V/V	100
N_C	10 V/V	1.00E-05	rectangular	5.77E-06	1.51E-05	8.72E-11 V/V	100
N_i	10 V/V	1.00E-05	rectangular	5.77E-06	1.51E-05	8.72E-11 V/V	100
C_{2n}	1000 nF	20 nF	rectangular	11.547 nF	14.31 F^{-1}	1.65E-07 V/V	100
C_{20}	1000 nF	20 nF	rectangular	11.547 nF	-1.59 F^{-1}	-1.84E-08 V/V	100
δb_s	0 V/V	5.00E-08 V/V	rectangular	2.89E-08 V/V	2.23606798	6.45E-08 V/V	100
δb_g	0 V/V	5.00E-08 V/V	rectangular	2.89E-08 V/V	3.16	9.13E-08 V/V	100
dev	0 V/V	2.20E-08 V/V	normal	2.20E-08 V/V	1	2.20E-08 V/V	2
					$k = 1$	2.15E-07 V/V	179
					$k = 2.01$	4.33E-07 V/V	

Output tap 0.5 Freq. 1 kHz In-phase							
Quantity	Estimate	Uncertainty	Distribution	Standard uncertainty	Sensitivity	Contribution	Degrees of freedom
X_i	x_i			$u(x_i)$	c_i	$u_i(y)$	
r	0.2 Ω	0.001 Ω	normal	0.001 Ω	9.99E-06 Ω^{-1}	9.99E-09 V/V	10
N_R	10 V/V	1.00E-05	rectangular	5.77E-06	-2.00E-06	-1.15E-11 V/V	100
N_i	10 V/V	1.00E-05	rectangular	5.77E-06	-2.00E-06	-1.15E-11 V/V	100
R_{2n}	10 k Ω	0.5 k Ω	rectangular	0.289 k Ω	5.6921E-11 Ω^{-1}	1.64E-08 V/V	100
R_{20}	10 k Ω	0.5 k Ω	rectangular	0.289 k Ω	-6.325E-12 Ω^{-1}	-1.83E-09 V/V	100
δa_c	0 V/V	5.00E-10 V/V	rectangular	2.89E-10 V/V	3.16	9.13E-10 V/V	100
δa_s	0 V/V	1.00E-09 V/V	rectangular	5.77E-10 V/V	2.24	1.29E-09 V/V	100
dev	0 V/V	6.00E-09 V/V	normal	6.00E-09 V/V	1.00	6.00E-09 V/V	2
					$k = 1$	2.03E-08 V/V	71
					$k = 2.04$	4.13E-08 V/V	

Output tap 0.5 Freq. 1 kHz Quadrature							
Quantity	Estimate	Uncertainty	Distribution	Standard uncertainty	Sensitivity	Contribution	Degrees of freedom
X_i	x_i			$u(x_i)$	c_i	$u_i(y)$	
r	0.2 Ω	0.001 Ω	normal	0.001 Ω	2.17E-05 Ω^{-1}	2.17E-08 V/V	10
ω	6283.185 rad/s	5.00E-03	normal	0.005	4.35E-06	2.17E-08 V/V	100
N_C	10 V/V	1.00E-05	rectangular	5.77E-06	-4.35E-06	-2.51E-11 V/V	100
N_i	10 V/V	1.00E-05	rectangular	5.77E-06	-4.35E-06	-2.51E-11 V/V	100
C_{2n}	100 nF	5 nF	rectangular	2.887 nF	35.76 F ⁻¹	1.03E-07 V/V	100
C_{20}	100 nF	5 nF	rectangular	2.887 nF	-3.97 F ⁻¹	-1.15E-08 V/V	100
δb_s	0 V/V	5.00E-08 V/V	rectangular	2.89E-08 V/V	2.23606798	6.45E-08 V/V	100
δb_g	0 V/V	5.00E-08 V/V	rectangular	2.89E-08 V/V	3.16	9.13E-08 V/V	100
dev	0 V/V	2.20E-08 V/V	normal	2.20E-08 V/V	1	2.20E-08 V/V	2
					$k = 1$	1.56E-07 V/V	274
					$k = 2.01$	3.13E-07 V/V	

A2.2. INM Uncertainty budget

The circuit which injects compensating error voltages, in phase and in quadrature is figured below. The voltage applied to the resistor r is described in the equation:

$$u_r = u_\alpha + j u_\beta = ((r/R) (k_\alpha - 0.5) + j (rC\omega) (k_\beta - 0.5)) \times k_\delta$$

The voltage ratio in the secondary of T_δ , on the twin components in phase and in quadrature are described as follows:

$$\begin{aligned} k_\alpha &= u_\alpha / U_{intrare} = (r/R) \times (D_\alpha - D_{0.5}) \times k_\delta + K_{IN} + K_{\hat{c}imp} + K_{Tara_raport} \\ k_\beta &= u_\beta / U_{intrare} = (rC\omega) \times (D_\beta - D_{0.5}) \times k_\delta + K_{IN} + K_{\hat{c}imp} + K_{Tara_unghi} \end{aligned}$$

where:

r – resistor on which is added compensation errors current ($r=2\Omega$)

R – injection resistor for in phase error ($R=2000 \Omega$);

C – injection capacitor for in quadrature error ($X_c=2000 \Omega$)

ω - pulsation of the signal;

D_α - dial of the inductive voltage divider used to inject in phase error current into resistor R ;

D_β - dial of the inductive voltage divider used to inject in quadrature error current into capacitor C ;

$D_{0.5}$ - fix 0.5 ratio used as reference for injection of the 2 components errors;

K_{IN} – contribution due to insufficient sensitivity of the null indicator

$K_{\hat{c}imp}$ – contribution due to insufficient shielding of the null indicator.

K_{Tara_raport} , K_{Tara_unghi} – contribution due to insufficient stability of the reference transformer on 2 components.

Combined uncertainty for k_α and k_β result, in hypothesis on uncorrelated input quantities from relation:

$$u_{c(y)}^2 = \sum_{i=1}^N \left(\frac{\partial f}{\partial x_i} \right)^2 u_{(xi)}^2$$

$$\begin{aligned} u_c^2(k_\alpha) &= (D_\alpha - D_{0.5})^2 \times (K_\delta/R)^2 \times u^2(r) + ((D_\alpha - D_{0.5}) \times K_\delta/R)^2 \times u^2(R) + (K_\delta \times r/R)^2 \times u^2(D_\alpha) + \\ &+ (Rr/R)^2 \times u^2(D_{0.5}) + \delta IN^2 \times u^2(IN) + \delta \hat{C}imp^2 \times u^2(\hat{C}imp) + \delta Tara^2 \times u^2(Tara) \end{aligned}$$

And respectively:

$$\begin{aligned} u_c^2(k_\beta) &= (D_\beta - D_{0.5})^2 \times (K_\delta/R)^2 \times u^2(r) + ((D_\beta - D_{0.5}) \times K_\delta \times 2 \times \pi \times f)^2 \times u^2(C) + \\ &+ ((D_\beta - D_{0.5}) \times K_\delta \times 2 \times \pi \times C)^2 \times u^2(f) + (K_\delta \times r/X_c)^2 \times u^2(D_\beta) + (Rr/X_c)^2 \times u^2(D_{0.5}) + \\ &+ \delta IN^2 \times u^2(IN) + \delta \hat{C}imp^2 \times u^2(\hat{C}imp) + \delta Tara^2 \times u^2(Tara) \end{aligned}$$

The uncertainty budgets for nominal ratio 0.5 are listed below.

Output tap 0.5 Freq. 55 Hz In-phase

Quantity X_i	Estimation x_i	Standard uncertainty $u(x_i)$	Probability distribution	Sensitivity coefficient c_i	Contribution to composed uncertainty u_i
ΔK_α	0.5	4×10^{-9}	Normal	1	4×10^{-9}
Δr	2.000Ω	0.10Ω	Normal	$0.5 \times 10^{-6} / \Omega$	50×10^{-9}
ΔR	2000Ω	10Ω	Normal	$5 \times 10^{-10} / \Omega$	5×10^{-9}
ΔD_α	0.00000019	1×10^{-6}	Normal	1×10^{-3}	1×10^{-9}
$\Delta D_{0.5}$	0.5	1×10^{-6}	Normal	1×10^{-3}	1×10^{-9}
δT_r	0.1	$(1 \times 10^{-9})/3^{0.5}$	Rectangular	1	0.6×10^{-9}
δInd	0	$(3 \times 10^{-9})/3^{0.5}$	Rectangular	1	1.7×10^{-9}
δC_{imp}	0	$(50 \times 10^{-9})/3^{0.5}$	Rectangular	1	28.8×10^{-9}
δT_{Tara}	0	$(2 \times 10^{-9})/3^{0.5}$	Rectangular	1	1.1×10^{-9}
K_α	0.499999981				58×10^{-9}

Output tap 0.5 Freq. 55 Hz In-quadrature

Mărimea de intrare X_i	Estimația x_i	Incertitudinea standard $u(x_i)$	Distribuția de probabilitate	Coefficientul de sensibilitate c_i	Contribuția la incertitudinea standard compusă u_i
ΔK_β	0.5	10×10^{-9}	normală	1	37×10^{-9}
Δr	2.000Ω	0.002Ω	normală	$0.5 \times 10^{-6} / \Omega$	1×10^{-9}
ΔX_C	2000Ω	2Ω	normală	$5 \times 10^{-10} / \Omega$	1×10^{-9}
Δf	50	0,01 Hz	normală	$5 \times 10^{-10} / \Omega$	6×10^{-9}
ΔD_α	0.00000008	$1 \times 10^{-6} \times 1$	normală	1×10^{-3}	1×10^{-9}
$\Delta D_{0.5}$	0.5	$1 \times 10^{-6} \times 1$	normală	-1×10^{-3}	1×10^{-9}
δT_r	0.1	$(1 \times 10^{-9})/\sqrt{3}$	Dreptunghiulară	1	1×10^{-9}
δInd	0	$(3 \times 10^{-9})/\sqrt{3}$	Dreptunghiulară	1	2×10^{-9}
δC_{imp}	0	$(300 \times 10^{-9})/\sqrt{3}$	Dreptunghiulară	1	150×10^{-9}
δT_{Tara}	0	$(7 \times 10^{-9})/\sqrt{3}$	Dreptunghiulară	1	7×10^{-9}
K_β	0.500000008				173×10^{-9}

Output tap 0.5 Freq. 400 Hz In-phase

Quantity X_i	Estimation x_i	Standard uncertainty $u(x_i)$	Probability distribution	Sensitivity coefficient c_i	Contribution to composed uncertainty u_i
ΔK_α	0.5	1×10^{-9}	Normal	1	1×10^{-9}
Δr	2.000Ω	0.10Ω	Normal	$0.5 \times 10^{-6} / \Omega$	50×10^{-9}
ΔR	2000Ω	10Ω	Normal	$5 \times 10^{-10} / \Omega$	5×10^{-9}
ΔD_α	-0.00000011	1×10^{-6}	Normal	1×10^{-3}	1×10^{-9}
$\Delta D_{0.5}$	0.5	1×10^{-6}	Normal	1×10^{-3}	1×10^{-9}
δT_r	0.1	$(1 \times 10^{-9})/3^{0.5}$	Rectangular	1	0.6×10^{-9}
δInd	0	$(3 \times 10^{-9})/3^{0.5}$	Rectangular	1	1.7×10^{-9}
δC_{imp}	0	$(50 \times 10^{-9})/3^{0.5}$	Rectangular	1	28.8×10^{-9}
$\delta Tara$	0	$(2 \times 10^{-9})/3^{0.5}$	Rectangular	1	1.1×10^{-9}
K_α	0.500000011				58×10^{-9}

Output tap 0.5 Freq. 400 Hz In-quadrature

Mărimea de intrare X_i	Estimația x_i	Incertitudinea standard $u(x_i)$	Distribuția de probabilitate	Coefficientul de sensibilitate c_i	Contribuția la incertitudinea standard compusă u_i
ΔK_β	0.5	10×10^{-9}	normală	1	12×10^{-9}
Δr	2.000Ω	0.002Ω	normală	$0.5 \times 10^{-6} / \Omega$	1×10^{-9}
ΔX_C	2000Ω	2Ω	normală	$5 \times 10^{-10} / \Omega$	1×10^{-9}
Δf	50	0,01 Hz	normală	$5 \times 10^{-10} / \Omega$	6×10^{-9}
ΔD_α	0.00000076	$1 \times 10^{-6} \times 1$	normală	1×10^{-3}	1×10^{-9}
$\Delta D_{0.5}$	0.5	$1 \times 10^{-6} \times 1$	normală	-1×10^{-3}	1×10^{-9}
δT_r	0.1	$(1 \times 10^{-9})/\sqrt{3}$	Dreptunghiulară	1	1×10^{-9}
δInd	0	$(3 \times 10^{-9})/\sqrt{3}$	Dreptunghiulară	1	2×10^{-9}
δC_{imp}	0	$(300 \times 10^{-9})/\sqrt{3}$	Dreptunghiulară	1	150×10^{-9}
$\delta Tara$	0	$(7 \times 10^{-9})/\sqrt{3}$	Dreptunghiulară	1	7×10^{-9}
K_β	0.500000076				173×10^{-9}

Output tap 0.5 Freq. 1 kHz In-phase

Quantity X_i	Estimation x_i	Standard uncertainty $u(x_i)$	Probability distribution	Sensitivity coefficient c_i	Contribution to composed uncertainty u_i
ΔK_α	0.5	3×10^{-9}	Normal	1	3×10^{-9}
Δr	2.000Ω	0.10Ω	Normal	$0.5 \times 10^{-6} / \Omega$	50×10^{-9}
ΔR	2000Ω	10Ω	Normal	$5 \times 10^{-10} / \Omega$	5×10^{-9}
ΔD_α	-0.00000011	1×10^{-6}	Normal	1×10^{-3}	1×10^{-9}
$\Delta D_{0.5}$	0.5	1×10^{-6}	Normal	1×10^{-3}	1×10^{-9}
δT_r	0.1	$(1 \times 10^{-9})/3^{0.5}$	Rectangular	1	0.6×10^{-9}
δInd	0	$(3 \times 10^{-9})/3^{0.5}$	Rectangular	1	1.7×10^{-9}
δC_{imp}	0	$(50 \times 10^{-9})/3^{0.5}$	Rectangular	1	28.8×10^{-9}
$\delta Tara$	0	$(2 \times 10^{-9})/3^{0.5}$	Rectangular	1	1.1×10^{-9}
K_α	0.500000011				58×10^{-9}

Output tap 0.5 Freq. 1 kHz In-quadrature

Mărimea de intrare X_i	Estimația x_i	Incertitudinea standard $u(x_i)$	Distribuția de probabilitate	Coefficientul de sensibilitate c_i	Contribuția la incertitudinea standard compusă u_i
ΔK_β	0.5	10×10^{-9}	normală	1	20×10^{-9}
Δr	2.000Ω	0.002Ω	normală	$0.5 \times 10^{-6} / \Omega$	1×10^{-9}
ΔX_C	2000Ω	2Ω	normală	$5 \times 10^{-10} / \Omega$	1×10^{-9}
Δf	50	0,01 Hz	normală	$5 \times 10^{-10} / \Omega$	6×10^{-9}
ΔD_α	0.00000196	$1 \times 10^{-6} \times 1$	normală	1×10^{-3}	1×10^{-9}
$\Delta D_{0.5}$	0.5	$1 \times 10^{-6} \times 1$	normală	-1×10^{-3}	1×10^{-9}
δT_r	0.1	$(1 \times 10^{-9})/\sqrt{3}$	Dreptunghiulară	1	1×10^{-9}
δInd	0	$(3 \times 10^{-9})/\sqrt{3}$	Dreptunghiulară	1	2×10^{-9}
δC_{imp}	0	$(300 \times 10^{-9})/\sqrt{3}$	Dreptunghiulară	1	150×10^{-9}
$\delta Tara$	0	$(7 \times 10^{-9})/\sqrt{3}$	Dreptunghiulară	1	7×10^{-9}
K_β	0.500000196				173×10^{-9}

Annex 3. Technical protocol

EUROMET Bilateral Comparison

Comparison of Alternating Voltage Ratio using an Inductive Voltage Divider

Technical Protocol

Contents

COMPARISON OF ALTERNATING VOLTAGE RATIO USING AN INDUCTIVE VOLTAGE DIVIDER

Technical Protocol	1
Contents	2
Introduction	3
Participation	3
Technical Requirements for the Comparison	3
Form of Comparison	3
Pre Comparison Activities	3
Handling of the Travelling Standard	3
Transportation of the Travelling Standard	4
Allotment of Time	4
Description of the Travelling Standard	4
Defining Conditions	4
Measurement Conditions	5
Mandatory Measurements	5
Measurement Uncertainty	6
Reporting of Results	6
Appendix A: Pilot Laboratory Details	7
Laboratory contacts	7
Apendix B Participating Laboratory	8

Introduction

This comparison is designated as a bilateral comparison for Euromet between NMi Van Swinden Laboratorium and NMi Van Swinden Laboratorium and National Institute of Metrology Bucharest Romania. The comparison will start in November 2004 and last 6 months, with the INM National Institute of Metrology Bucharest (INM) acting as the pilot laboratory. Contacts details for INM are listed in Appendix A.

This document supplements the document “Guidelines for the organisation of CCEM key comparisons” dated March 2003 hereafter called “The Guidelines”. In case of a conflict between the Guidelines and this document the Guidelines will take precedence unless there is an explicit statement to the contrary.

Participation

The participants laboratories must meet both the technical requirements for the comparison and the requirements in Appendix 1 of the Guidelines.

Technical Requirements for the Comparison

Participants should be able to measure both orthogonal components of the alternating voltage ratio of the travelling standard with an expanded uncertainty ($k=2$) of less than 200×10^{-9} of the input.

Participants must be able to conduct the measurements in equilibrium conditions at a temperature of either 20 ± 1 °C or 23 ± 1 °C in air; relative humidity $40 \% \pm 10 \%$ and frequencies uncertainty $U=0.3 \%$. Temperature is not a critical influence parameter in voltage ratio measurement.

Form of Comparison

By default, each stage of the comparison will consist of a measurement by a participating laboratory followed by a measurement by the pilot laboratory.

Pre Comparison Activities

The stability of the travelling standard will be assessed by repeated measurement interleaved by local travel at the pilot laboratory prior to the start of the comparison.

Handling of the Travelling Standard

The travelling standard should travel accompanied by a delegate.

The travelling standard should only be handled by authorised persons and stored in such a way as to prevent damage.

The travelling standard should be examined before dispatch and any change in condition during the measurement at each laboratory should be communicated to the pilot laboratory.

Transportation of the Travelling Standard

It is of utmost importance that the travelling standard be transported in a manner in which it will not be lost or damaged.

The travelling standard will be accompanied by a customs carnet where appropriate or documentation identifying the items uniquely.

Transportation is each laboratory's responsibility and cost. Each participating laboratory covers the costs for its own measurements, transportation and any customs charges as well as for any damages that may have occurred within its country. The pilot laboratory has no insurance for any loss or damage of the standards during transportation.

Allotment of Time

Each laboratory will receive the travelling standard according to an agreed timetable. A final set of measurements will be made at the end of the comparison by the pilot laboratory.

The comparison will be scheduled on a three days cycle, within this cycle each laboratory has 1 weeks for measurement. For the comparison to be completed on schedule it is important that participating laboratories abide by this schedule.

Week(s)	Operation
1	Shipment from pilot laboratory to participant laboratory
2	Measurement at participant laboratory
3	Shipment back to the pilot laboratory from participant laboratory
4-7	Measurement at the pilot laboratory
8-13	Issuing the preliminary raport of the participating laboratory o the pilot laboratory
7-14	Issuing by the by the pilot laboratory of thee draft A and draft B comparison report

Wherever possible, allowance will be made for extended national holidays e.g. Easter, Christmas and other periods of reduced activity e.g. summer recess.

Description of the Travelling Standard

The travelling standard is an auto-transformer, having a fixed set of ten taps. It is provided by the Romanian laboratory being a self construct device, type U.l.d.0-10x0,1 serial 8201. The device has a fixed ratio magnetising winding and a secondary decadic winding with nominal value of the ratio $k=0.1$ where $i=1 \dots 10$. Maximum input voltage must not exceed value deducted from formula:

$$U [V] = 0.15 \times f [\text{Hz}]$$

Defining Conditions

The voltage at a coaxial port is defined as the open circuit voltage existing between the inner and outer conductors of the coaxial connector at that port.

The INPUT VOLTAGE of the divider is defined as the voltage at the port marked "1" of the divider minus the voltage at the port marked "0".

The OUTPUT VOLTAGE of the divider at a given port is defined as the voltage at the port minus the voltage at the port marked "0".

The VOLTAGE RATIO of the divider at a given port is the complex quantity equal to the OUTPUT VOLTAGE divided by the INPUT VOLTAGE.

The NOMINAL VOLTAGE RATIO of a given port of the divider is a real number equal to the VOLTAGE RATIO of the corresponding port on an equivalent ideal divider.

The IN-PHASE VOLTAGE RATIO is the real part of the VOLTAGE RATIO.

The QUADRATURE VOLTAGE RATIO is the imaginary part of the VOLTAGE RATIO.

The IN-PHASE RATIO ERROR is the IN-PHASE RATIO minus the NOMINAL VOLTAGE RATIO.

Measurement Conditions

The divider should be energised with identical sinusoidal alternating voltages applied in parallel to the ports marked “premagnetizare”, 0 and 1,0. These voltages must be sufficiently stable in both frequency and amplitude for a single value, obtained from traceable calibrated instruments, to be given for each set of results. Amplitude values will be expressed in RMS [root-mean-square] Volts, frequencies in Hz.

It is recommended that the travelling standard be energised and given a minimum 2 hours to reach equilibrium with the laboratory environment before measurements are made.

The temperature of the case of the travelling standard must be measured using traceable calibrated instruments with an uncertainty of ± 0.5 °C or better.

The travelling standard is intended to be calibrated in an upright and level condition.

Mandatory Measurements

Frequency Hz	Input Volts V (rms)	Ratios
1000	10	0.1, 0.2, 0.3, 0.4, 0.5, 0.6, 0.7, 0.8, 0.9, 1.0

Frequency Hz	Input Volts V (rms)	Ratios
400	10	0.1, 0.2, 0.3, 0.4, 0.5, 0.6, 0.7, 0.8, 0.9, 1.0

Frequency Hz	Input Volts V (rms)	Ratios
55	10	0.1, 0.2, 0.3, 0.4, 0.5, 0.6, 0.7, 0.8, 0.9, 1.0

Measurement Uncertainty

The uncertainty of measurement shall be estimated according to the ISO Guide to the Expression of Uncertainty in Measurement for at least one measuring point at each frequency and the uncertainty contribution can be summarised in the uncertainty budget in Appendix C.

For a uncertainty evaluation based on comparable factors, the principal uncertainty contributions is listed, but usage of different measurement method restrict the uncertainty contributions.

- resistance standards;
- capacitance standard;
- standard voltage transformers;
- measuring frequency;
- reproductibility;
- electromagnetic fields;
- lack of sensitivity of the null detectors.

Reporting of Results

The results should be communicated to the pilot laboratory within 6 weeks of the completion of measurements.

Following receipt of all measurement reports from the participating laboratories, the pilot laboratory will analyse the results and prepare the reports on the comparison as required by the guidance document. The report should contain:

a description of the measuring method;

the ambient condition of the measurement: the temperature and humidity with limits of variation;

the values of other influence parameters: the frequency of the measuring signal and its uncertainty, the RMS value of the input voltage and its uncertainty;

the results of measurements;

the associated standard uncertainty, the effective degrees of freedom and the expanded uncertainty.

A summary of the measurement results will be presented by the participants.

Appendix A: Pilot Laboratory Details

Laboratory contacts

Name & E-Mail Address :	Phone Faximile	Location
Florin Mirea florin@inm.ro	+40213345060 ext. 170; +40213345345	11 Vitan-Birzesti Road, sector 4, zip code 042122, Bucharest, Romania
Gelu Popovici popovici@inm.ro	+40213345060 ext. 153; +40213345345	11 Vitan-Birzesti Road, sector 4, zip code 042122, Bucharest, Romania

Address for correspondence

Florin Mirea, 11 Vitan-Birzesti Road, sector 4, zip code 042122, Bucharest, Romania

Appendix B Participating Laboratory

Participant Identifier for Report Processing	Identifier for Table & Graphical Representation.	Participating Laboratory	Name & E-Mail Address :	Phone Faximile	Location
Nmi	Nmi	NMi Van Swinden Laboratorium	Erik Dierikx Contact-EL@nmi.nl	(+31) 15 269 1688	NMi-Van Swinden Laboratorium P.O. Box 654 NL-2600 AR DELFT The NETHERLANDS
INM	INM	National Institute of Metrology Bucharest	Florin Mirea florin@inm.ro	+40213345060 ext. 170; +40213345345	11 Vitan-Birzesti Road, sector 4, 042122, Bucharest, Romania

Appendix C Summary Of Uncertainty Budget

Quantity X_i	Estimate x_i	Standard Uncertainty $u(x_i)$	Sensitivity coefficient c_i	Contribution (abs.) $u_i(y)$
Standard uncertainty (k=1)				
Expanded uncertainty:				