

Final report
EURAMET Supplementary Comparison
EURAMET.EM.RF-S27

“Antenna factor for Loop Antennas”

Frédéric Pythoud⁽¹⁾, Michele Borsero⁽²⁾, Daniel Bownds⁽³⁾, Soydan ÇAKIR⁽⁴⁾, Mustafa ÇETİNTAŞ⁽⁴⁾, Karel Dražil⁽⁵⁾, David Gentle⁽³⁾, Domenico Giordano⁽²⁾, Stuart Harmon⁽³⁾, Josef Kupec⁽⁵⁾, Yannick Le Sage⁽⁶⁾, Beat Mühlemann⁽¹⁾, Michal Ulvr⁽⁵⁾, Giuseppe Vizio⁽²⁾, Dongsheng Zhao⁽⁷⁾

Mai 2014

¹Federal Institute of Metrology METAS, Lindenweg 50, 3003 Bern-Wabern, Switzerland,
frederic.pythoud@metas.ch

²Istituto Nazionale di Ricerca Metrologica (INRIM), Italy

³National Physical Laboratory (NPL), United Kingdom

⁴TÜBİTAK Ulusal Metroloji Enstitüsü (TÜBİTAK UME), Turkey

⁵Czech Metrology Institute (CMI), Czech Republic

⁶Laboratoire National de Métrologie et d'Essais (LNE), France

⁷VSL Dutch Metrology Institute (VSL), Netherlands

Abstract

The comparison of a loop antenna factor measurement has been performed. One of the motivations for this comparison was that since the last comparison in this field (CCEM.RF-S21.F), several National Metrology Institutes have implemented the calibration capabilities for antenna measurements. The second motivation is that the loop antennas are typically working over a large frequency range, in this case 10 Hz to 30 MHz. For the calibration over this frequency span, two ranges are distinguished: the low frequency range where Alternating Current (AC) techniques should be used, and the high frequency range where Radio-Frequency (RF) measurement techniques are applied. The comparison shows that the participants were able to measure within the declared uncertainties.

Table of contents

1	Introduction.....	4
1.1	Historical background.....	4
1.2	Technical background	4
1.3	Motivation	4
2	Organisation	5
2.1	Participants.....	5
2.2	Schedule	6
2.3	Unexpected incidents	6
3	Travelling standard.....	7
3.1	Description	7
3.2	Quantities to be measured:	7
3.2.1	Quantity 1: The antenna factor	7
3.2.2	Quantity 2: The complex reflection coefficient S11	8
3.3	Measurement instructions	8
3.4	Deviation from the protocol.....	8
4	Method of measurements.....	9
5	Stability of the standard.....	11
6	Measurement results.....	12
6.1	Results	12
6.2	Normalization of the results.....	13
6.3	Method of computation of the reference value	13
6.4	Degrees of equivalence.....	15
7	Summary and conclusions	18
8	References	19
9	Annex A: Graphical results for non-mandatory frequencies	20
10	Annex B: Graphical S11 at mandatory frequencies	33
11	Annex C: Participants protocol and uncertainty budget.....	37

1 Introduction

1.1 Historical background

In 2002-2004, the key comparison CCEM.RF-K21.F as well as the supplementary comparison CCEM.RF-S21.F [3] took place. The aim of these comparisons was to determine antenna factors of different kinds of antennas

- A. Schwarzbeck tuneable dipole, model UHAP: 300 MHz to 1 GHz
- B. Rohde & Schwarz log-periodic, model HL223: 200 MHz to 1.3 GHz
- C. Schaffner Chase bilog, model CBL 6112B: 30 MHz to 2 GHz
- D. Rohde & Schwarz active monopole HFH2-Z1: 9 kHz to 30 MHz
- E. EMCO active shielded loop, model 6507: 1 kHz to 30 MHz
- F. EMCO passive shielded loop, model 7604: 20 Hz to 150 kHz

At that time, only four laboratories participated in the comparison: NMI-VSL, AIST, KRISS and NPL. The frequency points were: 20 Hz, 500 Hz, 10 kHz, 100 kHz, 1 MHz, 30 MHz.

Since 2003, other National Metrology Institutes (NMI) like CMI, INRIM, LNE, UME, and METAS have implemented the calibration capabilities for loop antennas, so that it would be beneficial to perform a comparison again.

1.2 Technical background

A typical loop antenna may cover the frequency range from 10 Hz to 30 MHz. To cover this wide frequency range, Alternating Current (AC) measurement techniques and Radio-Frequency (RF) measurement techniques are needed.

The radiation of the antenna may be produced using:

- Helmholtz coils
- 3 antenna technique
- TEM cells

A typical broadband antenna calibration may be performed by combining different calibration methods.

1.3 Motivation

Due to the time span since the last comparison, and to the technical wide spectrum of this magnetic antenna calibration, it was decided to perform a new comparison for European NMIs.

2 Organisation

2.1 Participants

The pilot laboratory was METAS:

The members of the support group:
David Gentle (NPL)
Dongsheng Zhao (VSL)

The following NMI's participated in the comparison:

Acronym	Laboratory	Contact
CMI	Czech Metrology Institute Microwave Measurement Laboratory Regional Inspectorate Praha Radiova 3 102 00 Praha CZECH REPUBLIC	Mr Karel Drazil e-mail: kdrazil@cmi.cz phone: +420 266 020 173 (personal)
INRIM	Istituto Nazionale di Ricerca Metrologica Strada delle Cace 91 10135 Torino ITALY	Mr Michele Borsero e-mail: m.borsero@inrim.it phone: +39 011 3919 348 (personal) +39 011 3919.1 (central)
LNE	Laboratoire national de métrologie et d'essais 29, avenue Roger Hennequin 78197 Trappes cedex FRANCE	Mr Yannick Le Sage e-mail: yannick.lesage@lne.fr phone: +33 1 30 69 32 37 (personal) +33 1 30 69 10 00 (central)
METAS	Federal Institute of Metrology METAS EMC Laboratory Lindenweg 50 3003 Bern-Wabern SWITZERLAND	Mr Frédéric Pythoud e-mail: frederic.pythoud@metas.ch phone: +41 58 38 70 335 (personal) +41 58 38 70 111 (central)
VSL	VSL Dutch Metrology Institute Thijssseweg 11 2629JA Delft The Netherlands	Mr Dongsheng Zhao e-mail: DZhao@vsl.nl phone: + 31 15 269 1741 (office) + 31 15 269 1635 (lab) + 31 15 269 1636 (lab) + 31 15 269 1500 (central)
NPL	National Physical Laboratory Hampton Road Teddington Middlesex UK TW11 0LW	Mr David Gentle e-mail: David.Gentle@npl.co.uk phone: +44 20 8943 6717 (personal) +44 20 8977 3222 (central)
UME	TÜBİTAK UME PO 54 41470 Gebze - KOCAELİ TURKEY	Mr Mustafa Cetintas e-mail: Mustafa.Cetintas@tubitak.gov.tr phone: +90 533 460 79 74 (mobile) +90 262 679 50 00 (central)

2.2 Schedule

The measurements were performed, starting in August of the year 2011, according to the following time plan.

	Measurement Time	Participant
August 2011	1. July to 26. August 2011	METAS
September 2011	5. to 25. September 2011	NPL
October 2011	3. to 21. October 2011	VSL
November 2011	31. October to 18. November 2011	-
December 2011	28. November to 16. December 2011	<i>METAS (stability control)</i>
January 2012	9. January to 3 February 2012	INRIM
February 2012	6. February to 24 February 2012	LNE
March 2012	5. March to 23. March 2012	CMI
April 2012		<i>METAS (stability control)</i>
May - July 2012	14. May to 15. July 2012	UME
October 2012	1. October to 30. October 2012	<i>METAS (stability control)</i>

Transportation and dispatch

No special circulation method has been implemented. The transports were performed by post. On arrival at the participating laboratory, the devices and their packaging were carefully checked for any damage caused during transit.

2.3 Unexpected incidents

No incident to the travelling standard was reported.

3 Travelling standard

3.1 Description

The travelling standard is a shielded passive loop antenna:

Magnetic Field Pickup Coil, Rohde Schwarz HZ-10, S/N 100149.

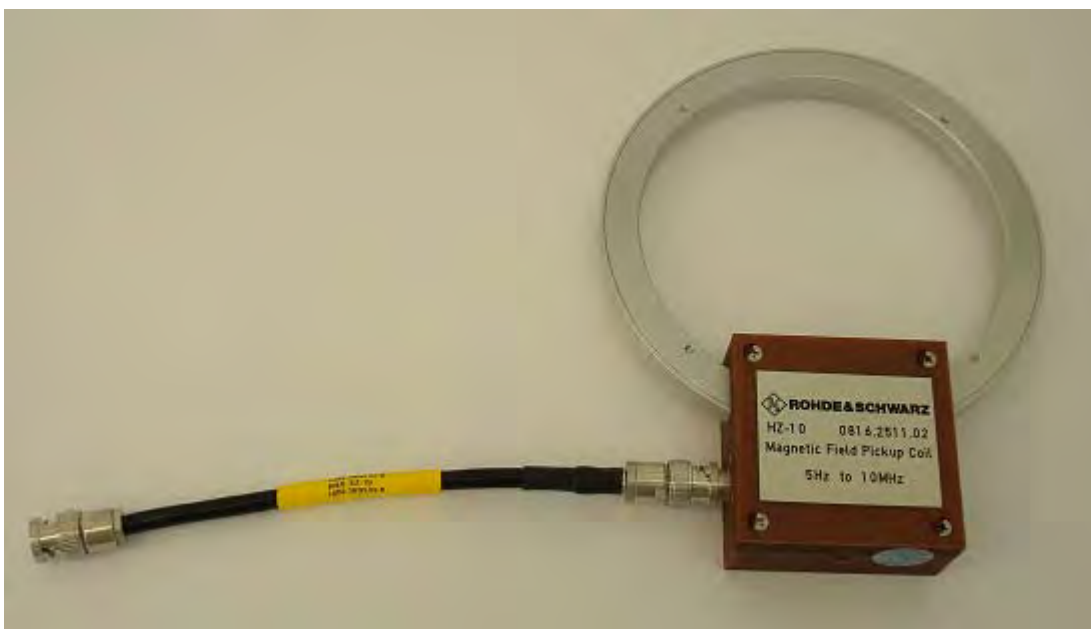

Frequency range: 5 Hz to 10 MHz.

Connector type: BNC.

3.2 Quantities to be measured:

3.2.1 Quantity 1: The antenna factor

The free field antenna factor AF , measured in dB(S/m), is defined by the ratio of the H-field H (measured in A/m) to the output voltage U (measured in V) across a conventional 50 Ω load:

$$AF = 20 \cdot \log_{10} \left(\frac{H}{U} \right)$$

Note: The free field antenna factor is sometimes expressed in dB(pT/ μ V). In this case, the following conversion has to be applied:

$$AF_{(pT/\mu V)} = \mu_0 \cdot 10^6 \cdot AF_{(S/m)}$$

or

$$AF_{(dB(pT/\mu V))} = 1.9841 + AF_{(dB(S/m))}$$

where:

- $AF_{(unit)}$ is the free field antenna factor expressed in *unit*.
- $\mu_0 = 4\pi \cdot 10^{-7}$ Vs/Am is the vacuum permeability

3.2.2 Quantity 2: The complex reflection coefficient S₁₁

The scattering parameter S_{11} at the BNC connector had to be measured. This coefficient is important for conversions of the free field antenna factor at the reference impedance of 50 Ω , to other reference impedances. While the S_{11} measurements are part of the comparison itself, the results are displayed informatively only, in the same way as for the comparison CCEM.RF-S21.F [3].

Note: The scattering parameter S_{11} is a parameter (complex dimensionless number) used mostly in the high frequency field. It can be obtained (useful for lower frequencies) from the complex input impedance Z as:

$$S_{11} = \frac{Z - Z_0}{Z + Z_0}$$

where Z_0 is the reference impedance (50 Ω in our case).

3.3 Measurement instructions

The following frequency points were requested according to the following table.

- **mandatory: 10 Hz, 100 Hz, 1 kHz, 10 kHz, 100 kHz, 1 MHz, 10 MHz**

- optional: (8 other points per decade):

10 Hz	20 Hz	30 Hz	40 Hz	50 Hz	60 Hz	70 Hz	80 Hz	90 Hz
100 Hz	200 Hz	300 Hz	400 Hz	500 Hz	600 Hz	700 Hz	800 Hz	900 Hz
1 kHz	2 kHz	3 kHz	4 kHz	5 kHz	6 kHz	7 kHz	8 kHz	9 kHz
10 kHz	20 kHz	30 kHz	40 kHz	50 kHz	60 kHz	70 kHz	80 kHz	90 kHz
100 kHz	200 kHz	300 kHz	400 kHz	500 kHz	600 kHz	700 kHz	800 kHz	900 kHz
1 MHz	2 MHz	3 MHz	4 MHz	5 MHz	6 MHz	7 MHz	8 MHz	9 MHz
10 MHz								

3.4 Deviation from the protocol

None.

4 Method of measurements

The measurement methods of each laboratory are reported in the participants' protocols (see Annex C). The following table provides an overview of the methods used.

	Low frequency Range	High frequency Range
METAS	Frequency Range: 10 Hz to 30 kHz Method: 3 antenna method Instrumentation: Signal generator and receiver	Frequency Range: 30 kHz to 10 MHz Method: GTEM cell Instrumentation: Signal generator and receiver
NPL1	Frequency Range: 10 Hz to 10 MHz Method: TEM cell (correction of wave impedance for low frequencies) Instrumentation: Vector signal generator	
NPL2	Frequency Range: 10 Hz to 120 kHz Method: Helmholtz coil calibrated at DC with proton resonance magnetometer Instrumentation: AC source and digital multi-meter	
VSL	Frequency Range: 10 Hz to 100 kHz Method: Helmholtz coil Instrumentation: Lock-in analyser and Digital Multimeter	Frequency Range: 10 kHz to 10 MHz Method: TEM cell Instrumentation: Vector network analyser
INRIM	Frequency Range: 10 Hz to 100 kHz Method: Helmholtz coil Instrumentation: lock-in analyser and digital multi-meter	Frequency Range: 9 kHz to 10 MHz Method: Loop antenna according to "Standard field method" Instrumentation: Signal generator and power meter
LNE		Frequency Range: 9 kHz to 10 MHz Method: Substitution method to another calibrated loop antenna (NPL) Instrumentation: Synthesizer and spectrum analyser.
CMI1	Frequency Range: 10 Hz to 10 MHz Method: Helmholtz coil Instrumentation: Calibrator with transconductance amplifier and AC voltmeter up to 5 kHz, signal generator with AC voltmeter (up to 100 kHz) or RF power meters (above 100 kHz).	
CMI2	Frequency Range: 10 Hz to 100 kHz Method: Helmholtz coil Instrumentation: arbitrary waveform generator with digital multi-meter.	
UME	Frequency Range: 10 Hz to 10 MHz Method: Calculable loop antenna as source. Different types of antennas used according to the frequency range. Instrumentation: Signal generator and oscilloscope / EMI receiver.	

CMI also performed measurements with two alternative methods. Since these two measurements were proposed, the principles are listed below. However, the results are not included in the analysis. The uncertainties of these measurements are larger or comparable with the measurements reported as CMI1.

	Low frequency Range	High frequency Range
CMI		Frequency Range: 100 kHz to 10MHz Method: Calculable loop antenna as source. Instrumentation: Signal generator, measuring receiver
CMI		Frequency Range: 100 kHz to 10MHz Method: TEM cell Instrumentation: Signal generator, RF power meters

5 Stability of the standard

The stability of the standard, obtained from the METAS measurements, is shown graphically in the following picture:

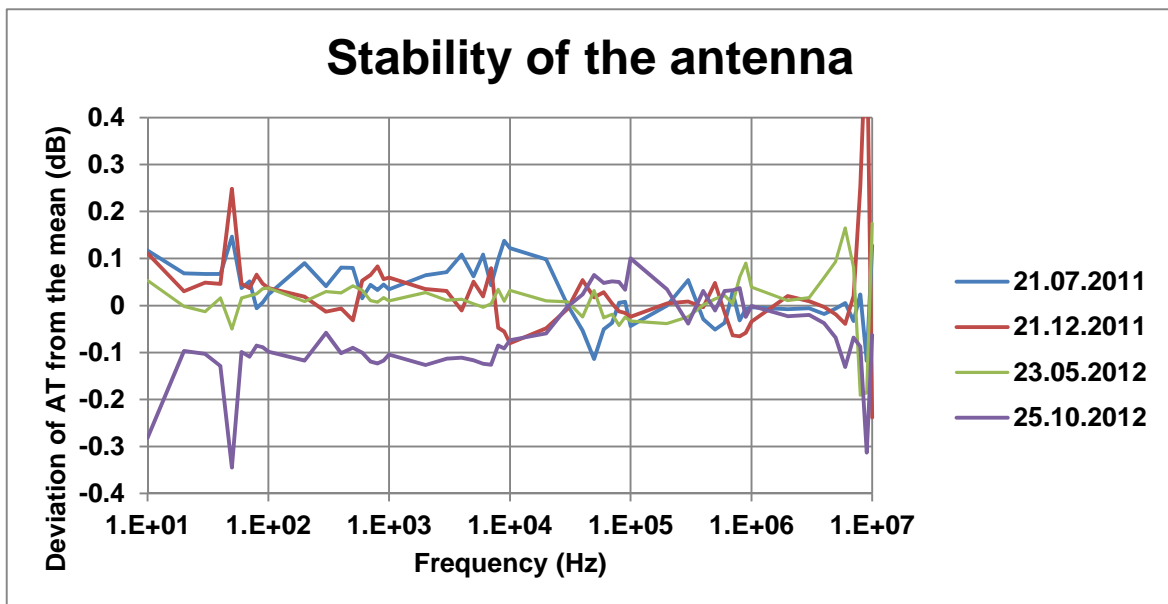

Considering the uncertainty of the measurements (0.11 dB to 0.24 dB ($k=1$) depending of the frequency range), the stability of the standard is considered as good for almost all frequencies except:

- at 50 Hz where the instability is probably due to 50 Hz pollution.
- at 9 MHz and 10 MHz. These frequencies are the maximum frequencies according to the specifications of the antenna, and the instabilities can be explained simply by this observation.

Moreover, some participants were able to measure the antenna factor with a much lower uncertainty. Their measurements are very consistent (see section 6), thus confirming the perfect stability of the antenna.

Therefore, no additional uncertainty corrections have been added to the participant's results, nor has any drift correction been performed.

6 Measurement results

6.1 Results

Note: For S11 measurements, see Annex B.

In the following tables, the measurement results for the antenna factors at the mandatory frequency points are listed.

10 Hz		
Lab	Antenna Factor dB (S/m)	Std Unc. ($k=1$) (dB)
METAS	89.871	0.190
NPL1	89.400	0.370
NPL2	89.598	0.010
VSL	89.575	0.140
INRIM	89.597	0.034
LNE	-	-
CMI1	89.609	0.070
CMI2	89.480	0.150
UME	88.500	0.830

100 Hz		
Lab	Antenna Factor dB (S/m)	Std Unc. ($k=1$) (dB)
METAS	69.743	0.110
NPL1	69.633	0.360
NPL2	69.595	0.011
VSL	69.575	0.140
INRIM	69.608	0.030
LNE	-	-
CMI1	69.615	0.070
CMI2	69.550	0.040
UME	68.810	0.800

1 kHz		
Lab	Antenna Factor dB (S/m)	Std Unc . ($k=1$) (dB)
METAS	50.026	0.110
NPL1	49.776	0.310
NPL2	49.934	0.011
VSL	49.887	0.140
INRIM	49.954	0.029
LNE	-	-
CMI1	49.959	0.070
CMI2	49.920	0.040
UME	49.120	0.800

10 kHz		
Lab	Antenna Factor dB (S/m)	Std Unc . ($k=1$) (dB)
METAS	31.523	0.110
NPL1	30.979	0.290
NPL2	31.333	0.011
VSL	31.301	0.140
INRIM	31.356	0.029
LNE	29.872	0.610
CMI1	31.389	0.121
CMI2	31.320	0.050
UME	30.660	0.800

100 kHz		
Lab	Antenna Factor dB (S/m)	Std Unc . (<i>k</i> =1) (dB)
METAS	23.596	0.240
NPL1	22.817	0.290
NPL2	23.290	0.030
VSL	23.177	0.200
INRIM	23.294	0.033
LNE	21.713	0.610
CMI1	23.286	0.122
CMI2	23.150	0.200
UME	22.810	0.800

1 MHz		
Lab	Antenna Factor dB (S/m)	Std Unc . (<i>k</i> =1) (dB)
METAS	23.371	0.240
NPL1	22.467	0.290
NPL2	-	-
VSL	22.854	0.200
INRIM	22.960	0.546
LNE	21.356	0.610
CMI1	23.042	0.209
CMI2	-	-
UME	22.100	0.700

10 MHz		
Lab	Antenna Factor dB (S/m)	Std Unc . (<i>k</i> =1) (dB)
METAS	25.272	0.230
NPL1	24.154	0.290
NPL2	-	-
VSL	24.395	0.360
INRIM	23.950	0.562
LNE	23.814	0.600
CMI1	24.513	0.287
CMI2	-	-
UME	25.710	0.700

6.2 Normalization of the results

None.

6.3 Method of computation of the reference value

NPL and CMI provided two sets of measurements each (CMI even more, but only two of them were considered). For the evaluation of the Comparison Reference Value (CRV), only one measurement per laboratory was taken into account. The measurement with the smallest uncertainty has been chosen; the other one is reported in the tables and displayed in the graphics informatively (with a circle instead of a dish).

The CRV y has been determined as a weighted average (following Procedure A of [2]) as

$$y = \frac{x_1 / u^2(x_1) + \dots + x_N / u^2(x_N)}{1 / u^2(x_1) + \dots + 1 / u^2(x_N)}$$

Where x_i are the participants measurements and u_i their uncertainties ($k=1$). It should be noted that the LNE takes traceability from NPL, so in that respect, the procedure A should

not be used. But given the fact that LNE's uncertainties are quite high, it would not have a significant effect on the calculations. The standard deviation $u(y)$ of y is given by:

$$\frac{1}{u^2(y)} = \frac{1}{u^2(x_1)} + \dots + \frac{1}{u^2(x_N)}.$$

The degree of equivalence d_i has been determined as

$$d_i = x_i - y$$

and its uncertainty $u(d_i)$ as:

$$u^2(d_i) = u^2(x_i) - u^2(y) \text{ for values that contributed to the reference value}$$

$$u^2(d_i) = u^2(x_i) + u^2(y) \text{ for values that did not contribute to the reference value}$$

With the exception of the last frequency (10 MHz), the consistency check according to procedure A of [2] (chi-squared test) is successful. Therefore no outlier procedure has been applied.

The following values are obtained:

Frequency	CRV Antenna Factor dB (S/m)	Std Unc. (k=1) (dB)
10 Hz	89.599	0.009
100 Hz	69.595	0.010
1 kHz	49.936	0.010
10 kHz	31.336	0.010
100 kHz	23.290	0.022
1 MHz	22.895	0.108
10 MHz	24.647	0.131

Traditional graphical representation of the comparison results, as well as degree of equivalence matrices are provided at the following mandatory frequencies: 10 Hz, 100 Hz, 1 kHz, 10 kHz, 100 kHz, 1 MHz, and 10 MHz.

For the remaining frequencies, the results of the participants are shown in annex A in terms of a curve on an X/Y graph with

- X-axis: frequency
- Y-axis: deviation from Comparison Reference Value (CRV).

6.4 Degrees of equivalence

10 Hz		
Lab	Deviation from CRV (dB)	Unc. ($k=2$) (dB)
METAS	0.272	0.380
NPL1	-0.198	0.740
NPL2	-0.001	0.006
VSL	-0.024	0.279
INRIM	-0.001	0.066
LNE	-	-
CMI1	0.010	0.139
CMI2	-0.119	0.301
UME	-1.099	1.660

100 Hz		
Lab	Deviation from CRV (dB)	Unc. ($k=2$) (dB)
METAS	0.149	0.219
NPL1	0.038	0.720
NPL2	0.000	0.009
VSL	-0.020	0.279
INRIM	0.013	0.056
LNE	-	-
CMI1	0.020	0.141
CMI2	-0.045	0.078
UME	-0.785	1.600

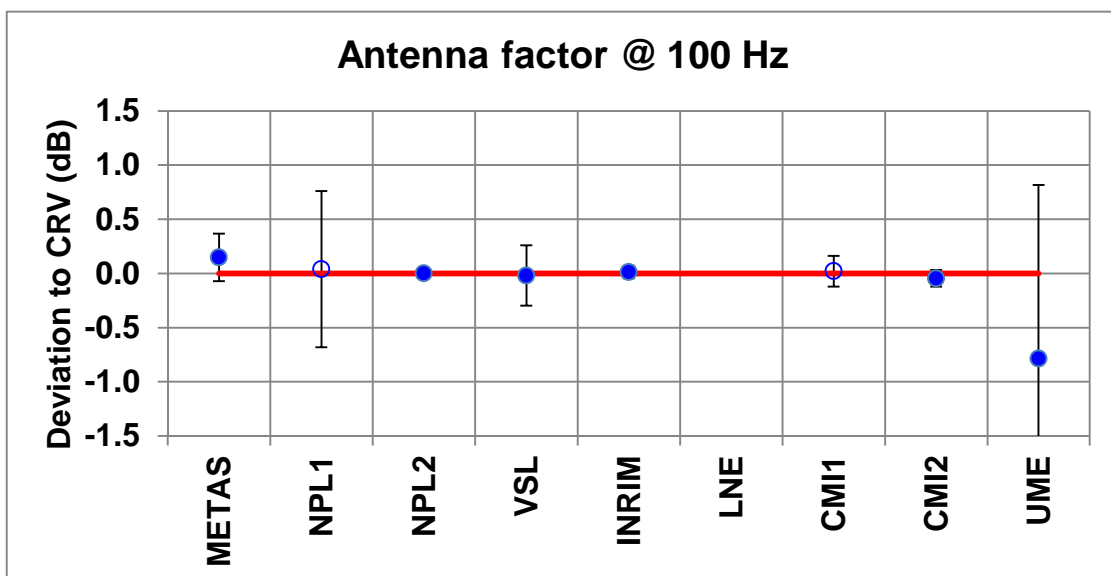
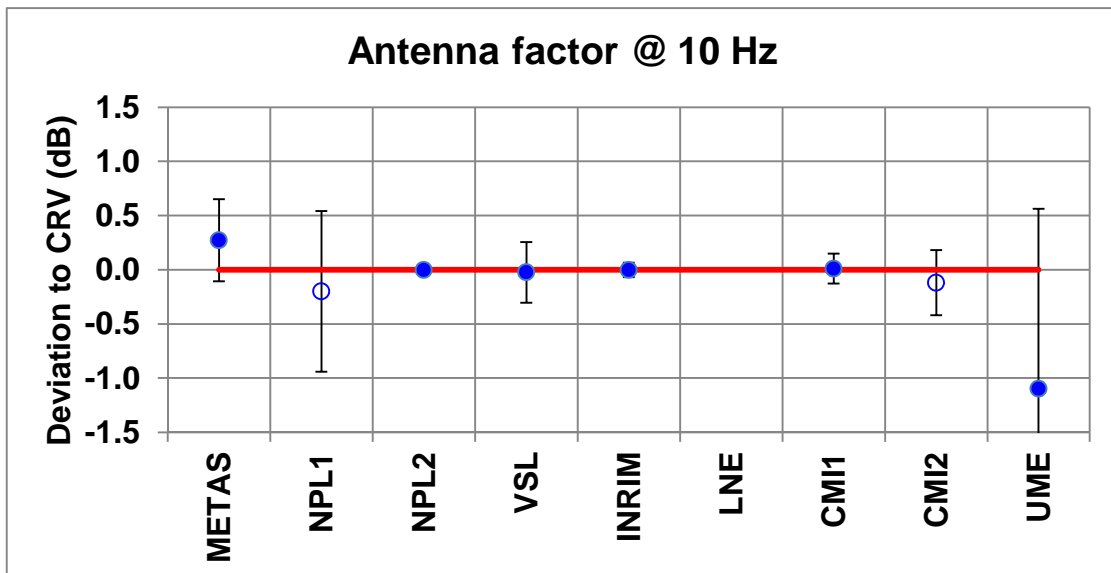

1 kHz		
Lab	Deviation from CRV dB()	Unc. ($k=2$) (dB)
METAS	0.090	0.219
NPL1	-0.160	0.620
NPL2	-0.002	0.009
VSL	-0.048	0.279
INRIM	0.018	0.056
LNE	-	-
CMI1	0.024	0.141
CMI2	-0.016	0.078
UME	-0.816	1.600

10 kHz		
Lab	Deviation from CRV dB()	Unc. ($k=2$) (dB)
METAS	0.187	0.219
NPL1	-0.357	0.580
NPL2	-0.003	0.008
VSL	-0.035	0.279
INRIM	0.020	0.056
LNE	-1.464	1.220
CMI1	0.054	0.244
CMI2	-0.016	0.098
UME	-0.676	1.600

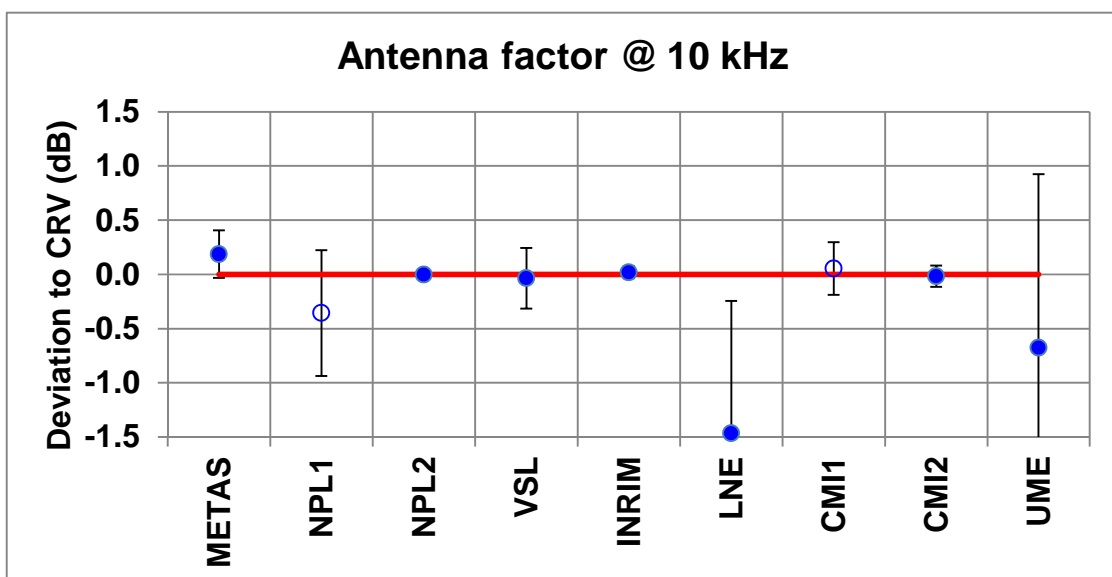
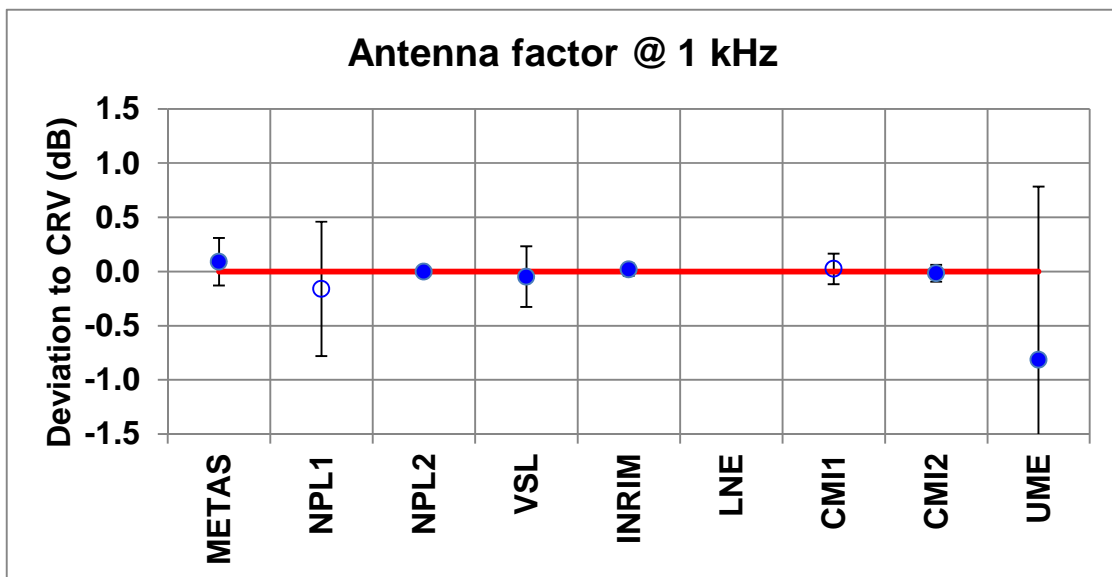

100 kHz		
Lab	Deviation from CRV dB()	Unc. ($k=2$) (dB)
METAS	0.305	0.478
NPL1	-0.473	0.582
NPL2	0.000	0.042
VSL	-0.114	0.398
INRIM	0.003	0.050
LNE	-1.577	1.219
CMI1	-0.004	0.239
CMI2	-0.140	0.402
UME	-0.480	1.599

1 MHz		
Lab	Deviation from CRV dB()	Unc. ($k=2$) (dB)
METAS	0.477	0.428
NPL1	-0.427	0.538
NPL2	-	-
VSL	-0.041	0.336
INRIM	0.065	1.071
LNE	-1.538	1.201
CMI1	0.147	0.358
CMI2	-	-
UME	-0.795	1.383

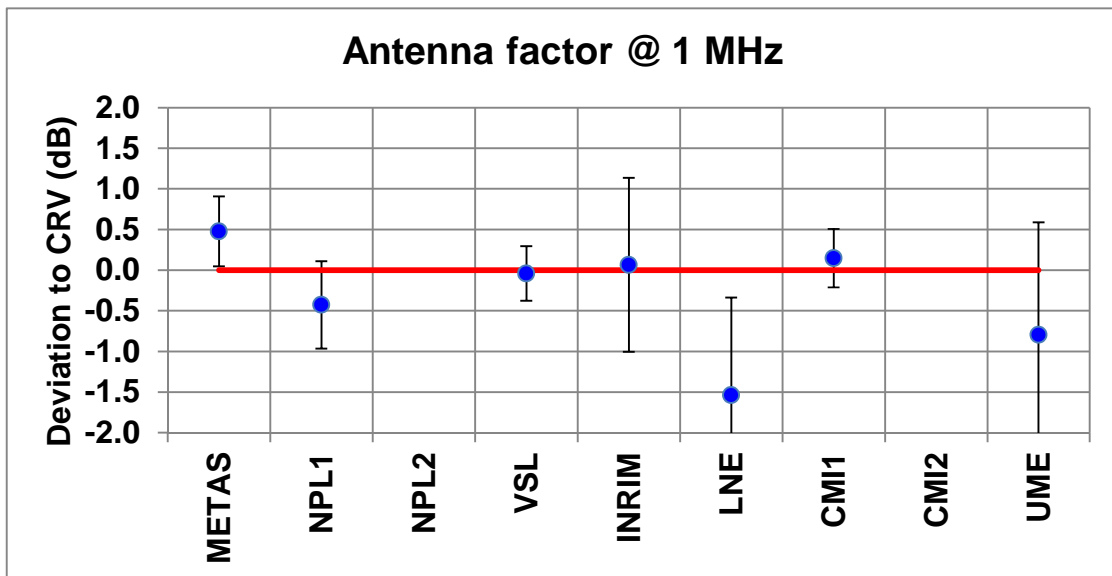
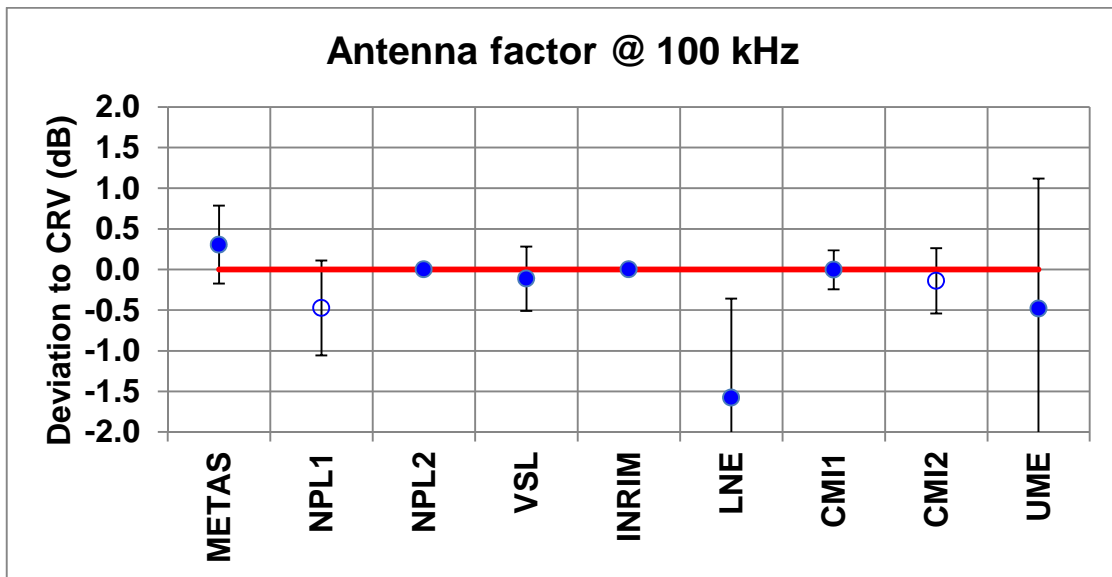

10 MHz		
Lab	Deviation from CRV dB()	Unc. ($k=2$) (dB)
METAS	0.624	0.379
NPL1	-0.493	0.518
NPL2	-	-
VSL	-0.252	0.671
INRIM	-0.697	1.093
LNE	-0.833	1.171
CMI1	-0.134	0.510
CMI2	-	-
UME	1.063	1.375

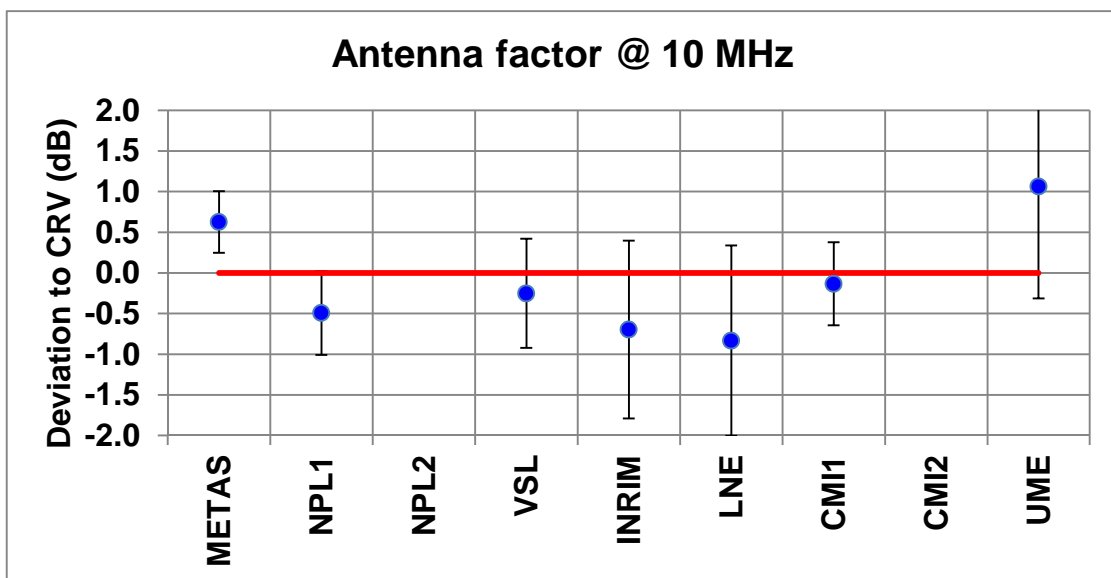

7 Summary and conclusions

Visual inspection of the graphs shows that generally most of the results are consistent with the declared uncertainty. Some laboratories show systematic deviation as confirmed by the measurements at the non-mandatory frequencies reported in Annex A. This comparison should serve to either identify the source of an actually unperformed correction, or to adapt the uncertainty budget.

A few labs (NPL and CMI and also INRIM) could measure the antenna factor with significantly lower uncertainties than the other participants. Their results were very consistent with each other, thus confirming the quality of their measurements as well as the stability of the travelling standard.

Considering the best achievable uncertainties, the results show also two distinct frequency ranges:

- The frequency range from 10 Hz to 100 kHz where typical uncertainties of a hundredths of dBs can be achieved.
- The frequency range above 100 kHz where typical uncertainties of tenths of dBs are obtained.

This confirms the fact that, to cover the wide frequency range, two different techniques have to be used:

- Alternating Current (AC) measurement techniques, where low uncertainties are available.
- Radio-Frequency (RF) measurement techniques with higher uncertainties.

8 References

- [1] CCEM Guidelines for Planning, Organizing, Conducting and Reporting Key, Supplementary and Pilot Comparisons, March 21, 2007.
http://www.bipm.org/utils/common/pdf/ccem_guidelines.pdf.
- [2] W. Bich, M. Cox, T. Estler, L. Nielsen, W. Woeger, "Proposed guidelines for the evaluation of key comparison data", April 2002. Available at:
<http://www.bipm.org/cc/CCAUV/Allowed/3/CCAUV02-36.pdf>.
- [3] D. A. Knight, M. J. Alexander, "Supplementary comparison: CCEM.RF-S21.F: Final Report", October 2005.
http://www.bipm.org/utils/common/pdf/final_reports/EM/RF/S21/CCEM.RF-S21.F.pdf.

9 Annex A: Graphical results for non-mandatory frequencies

Note: Uncertainty bars are for $k=2$.

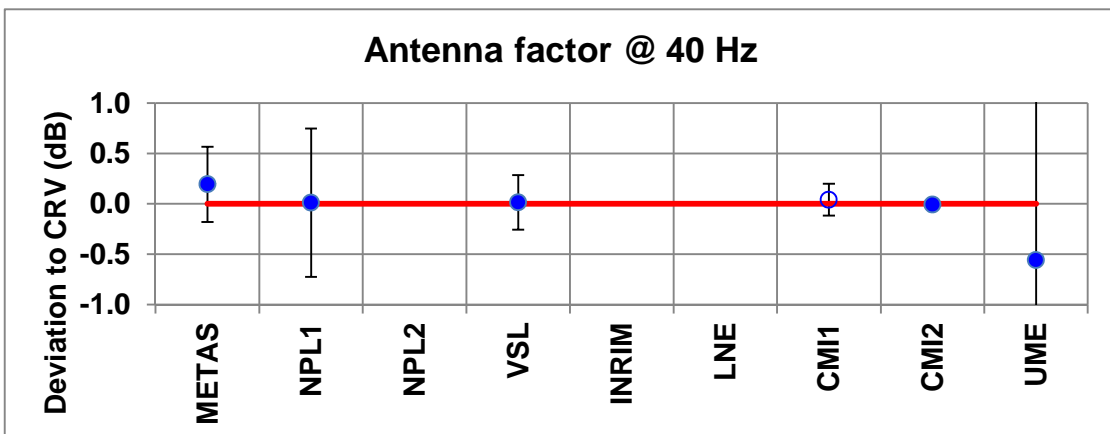
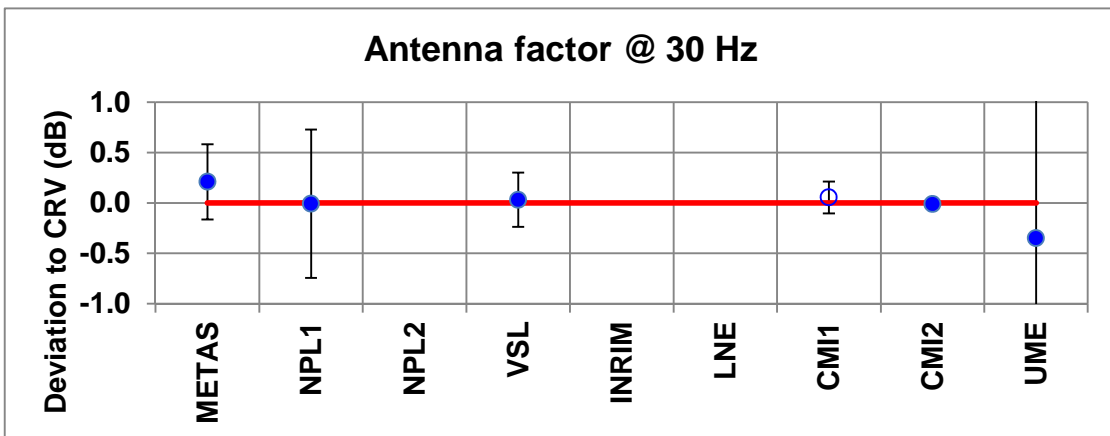
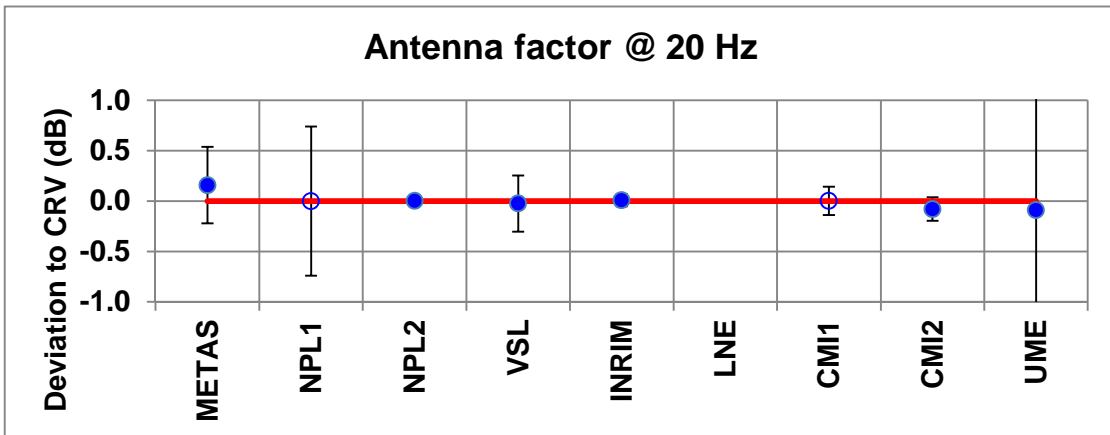

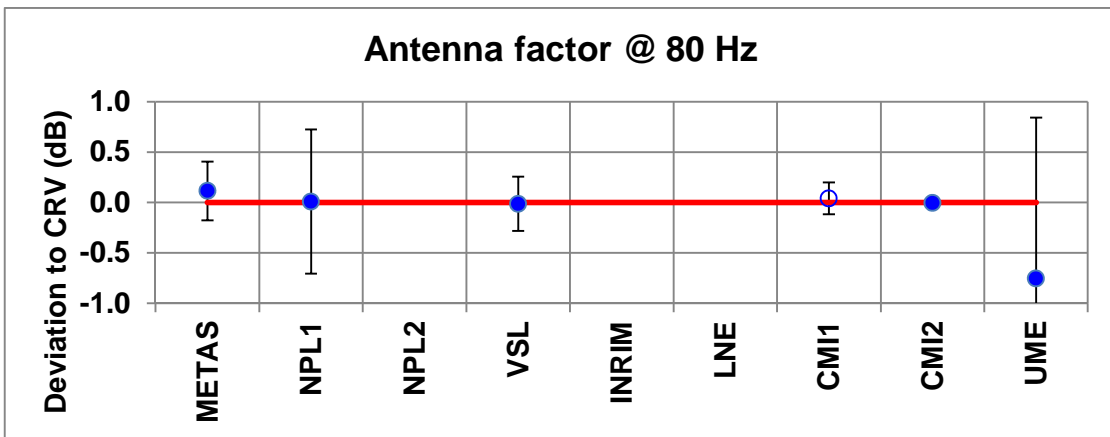
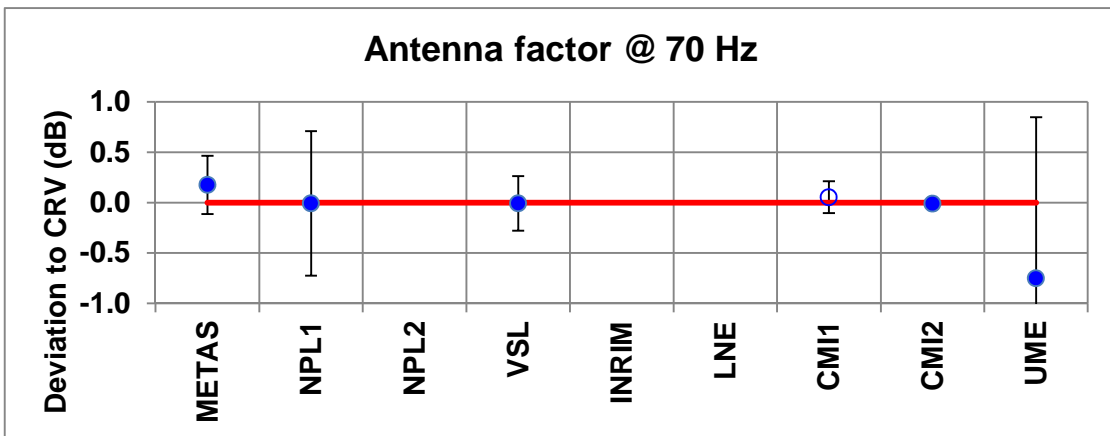
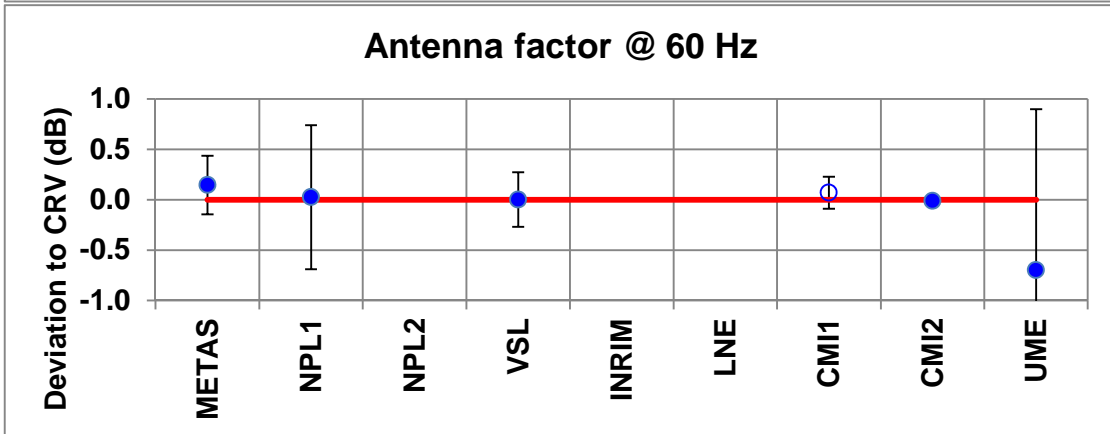
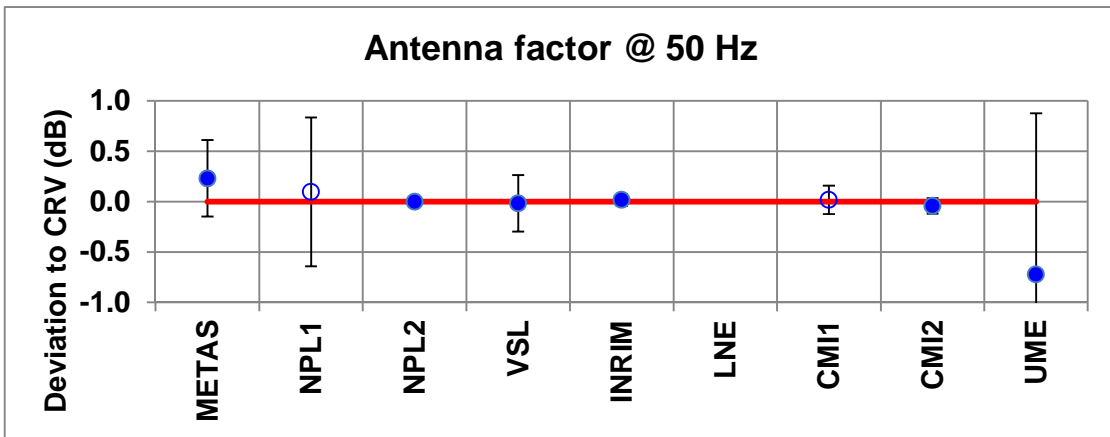

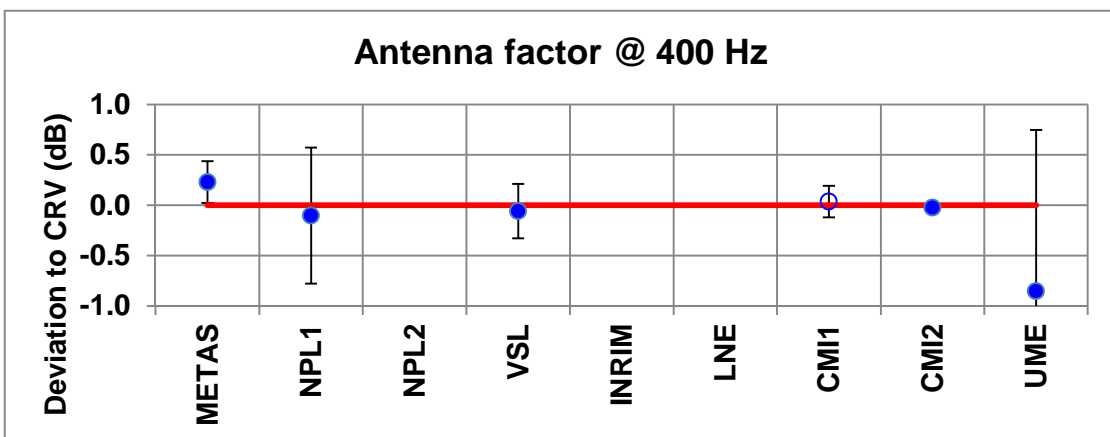
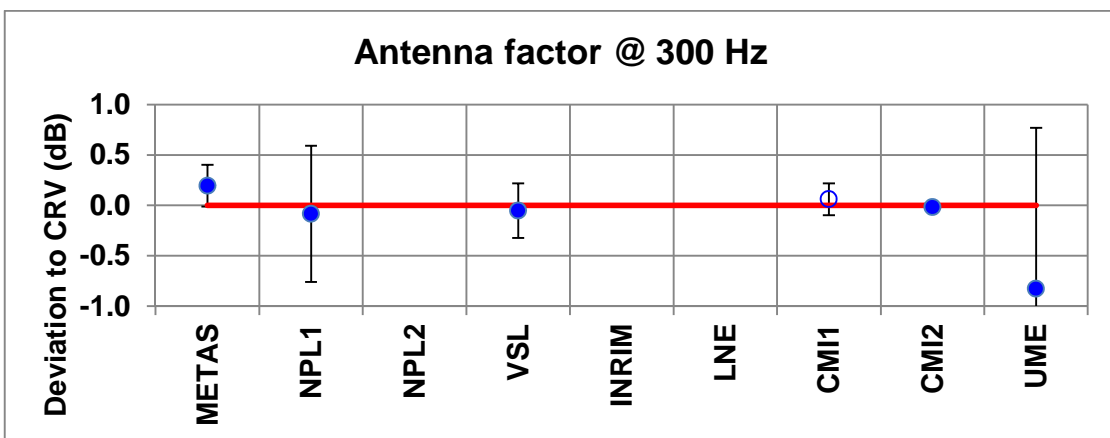
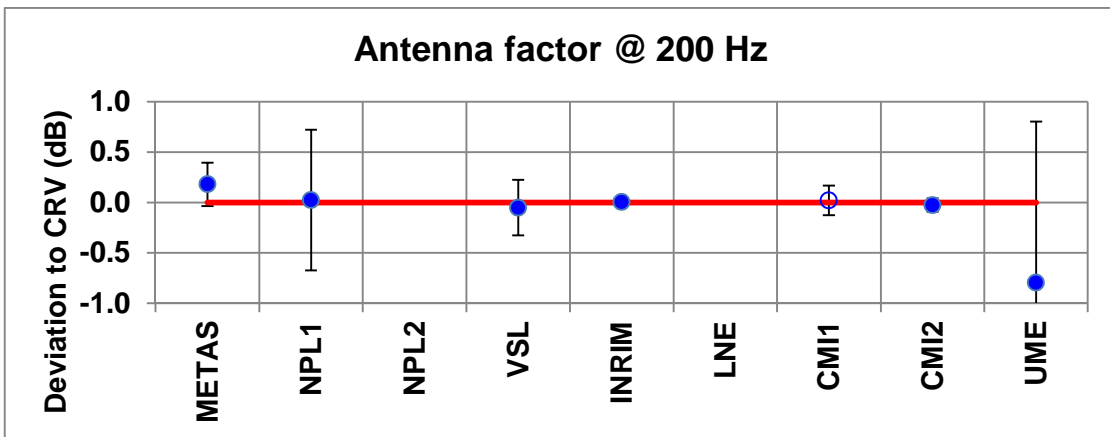
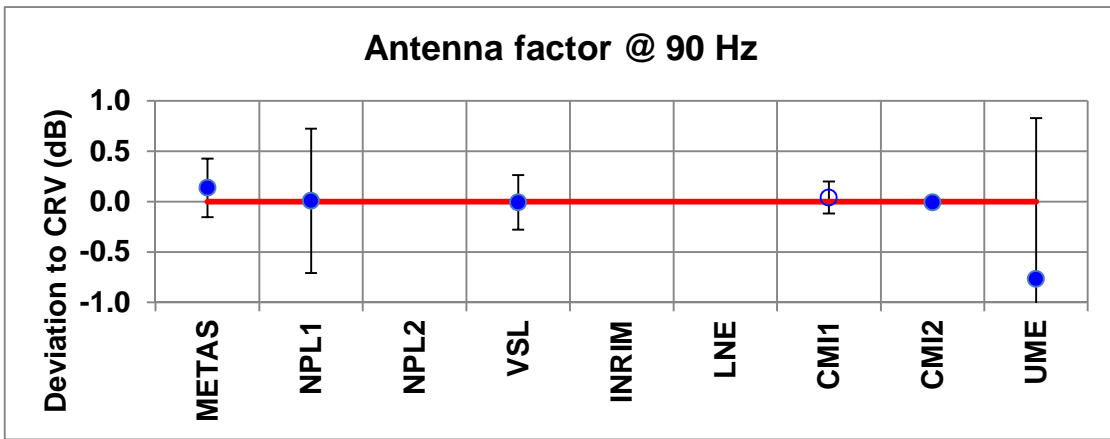

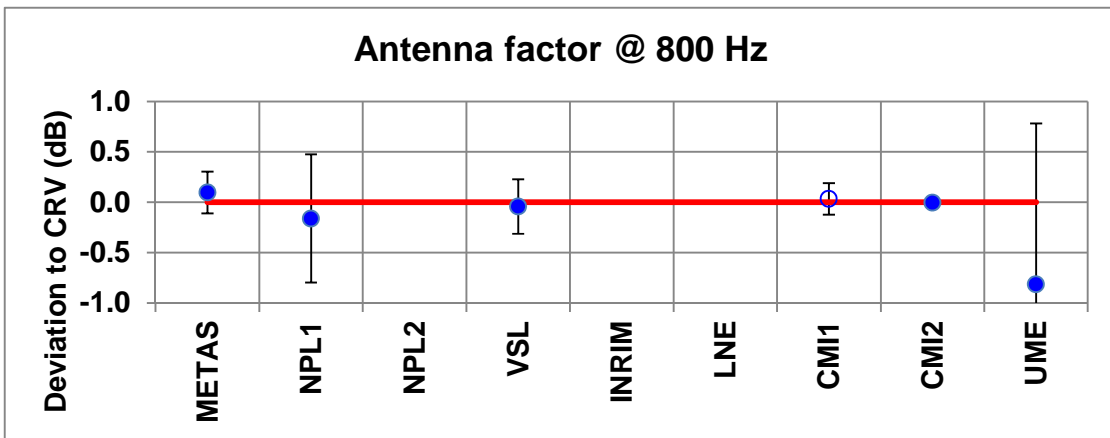
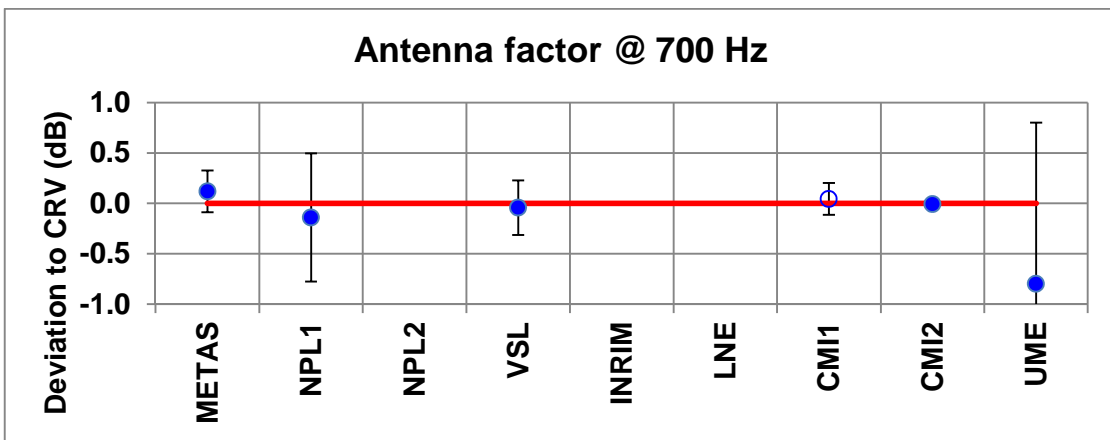
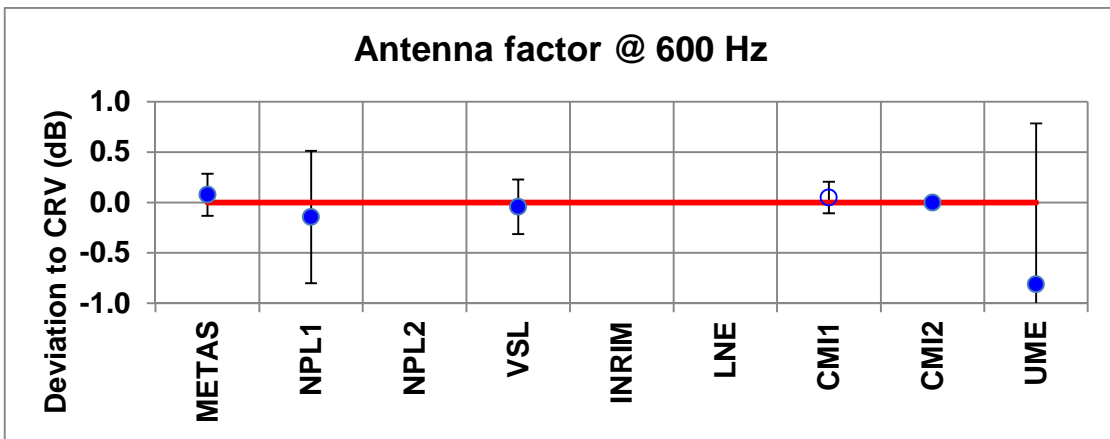
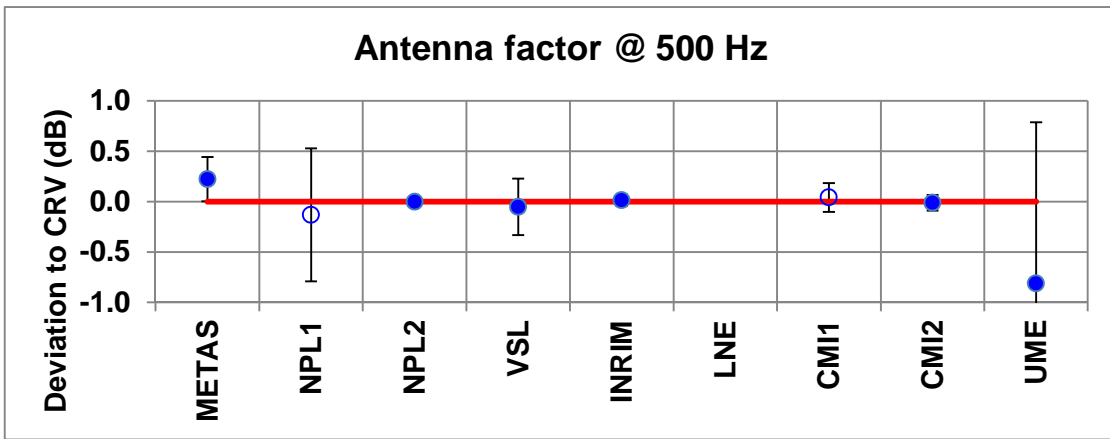

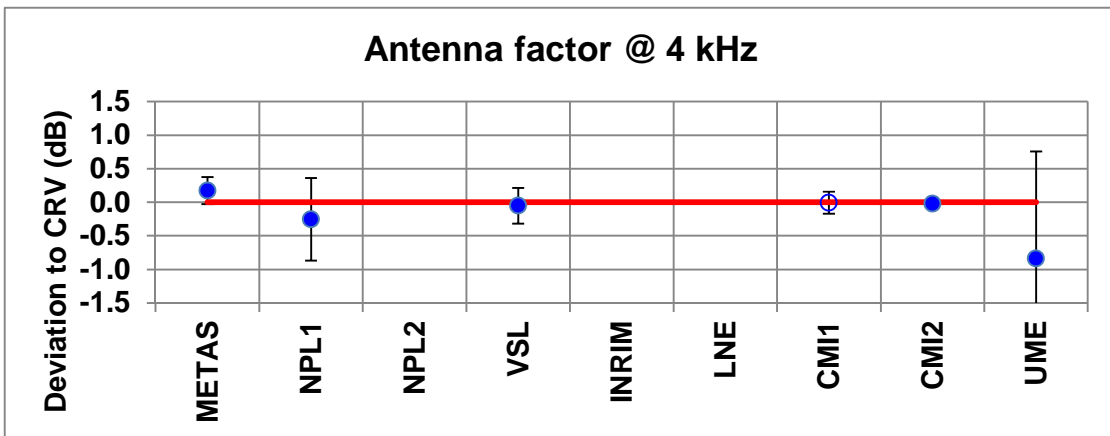
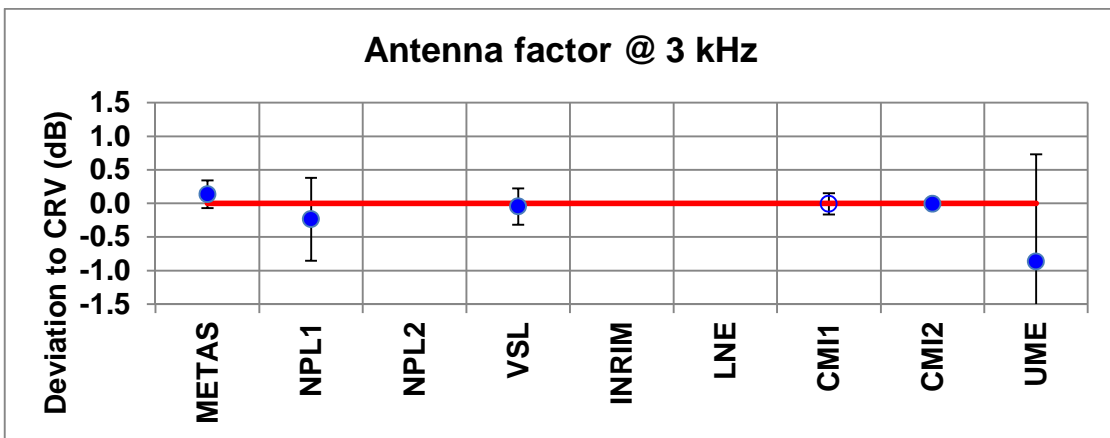
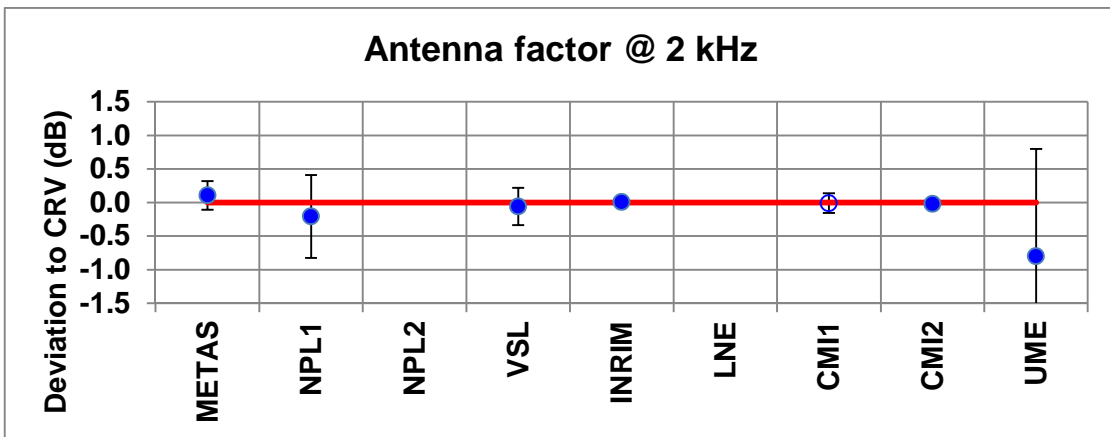
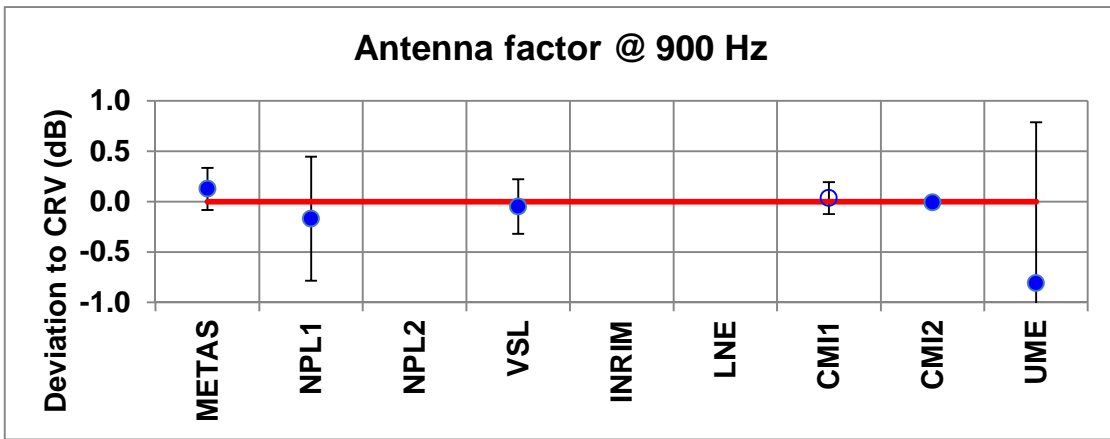

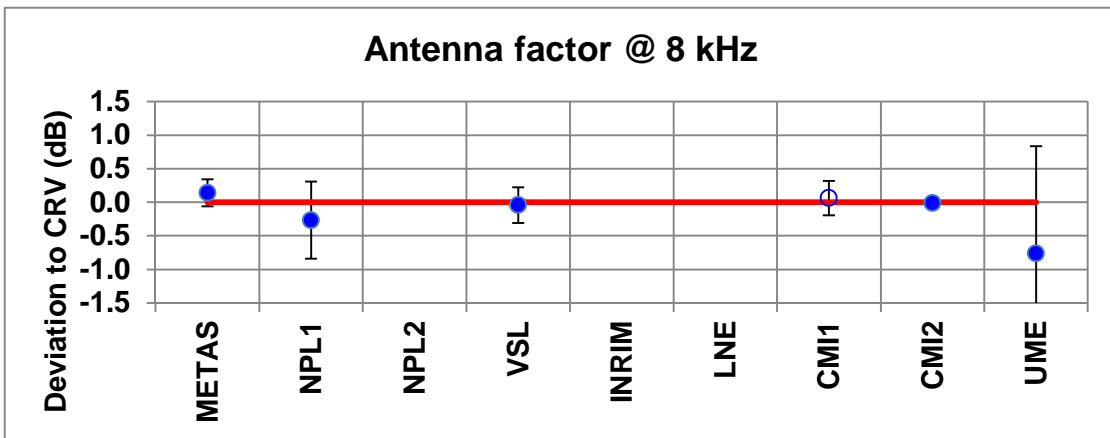
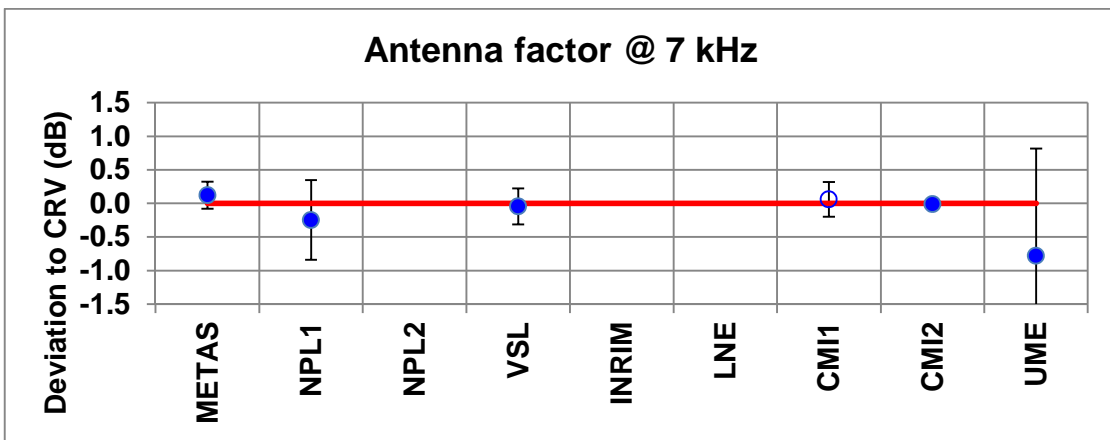
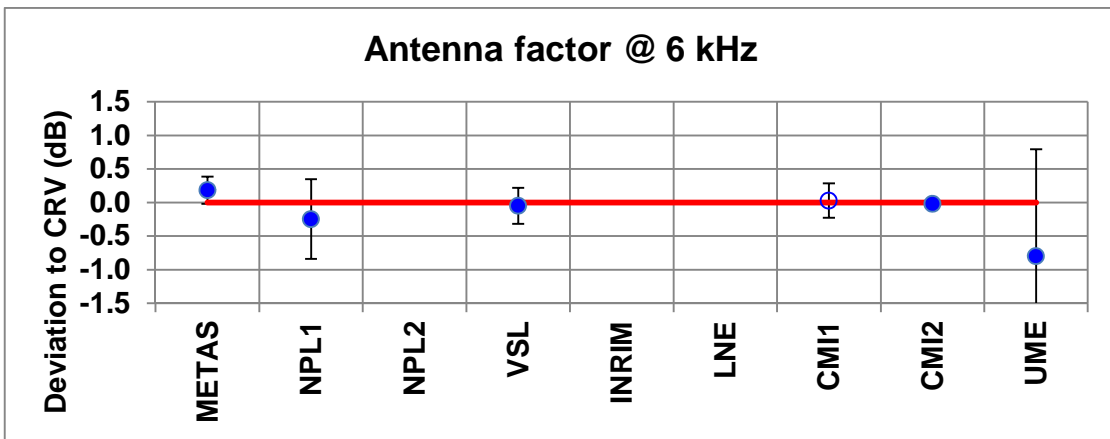
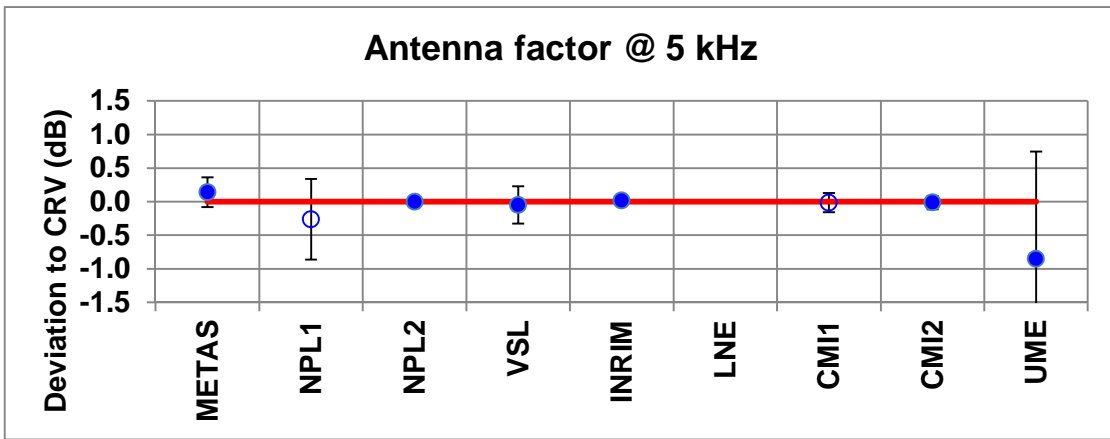

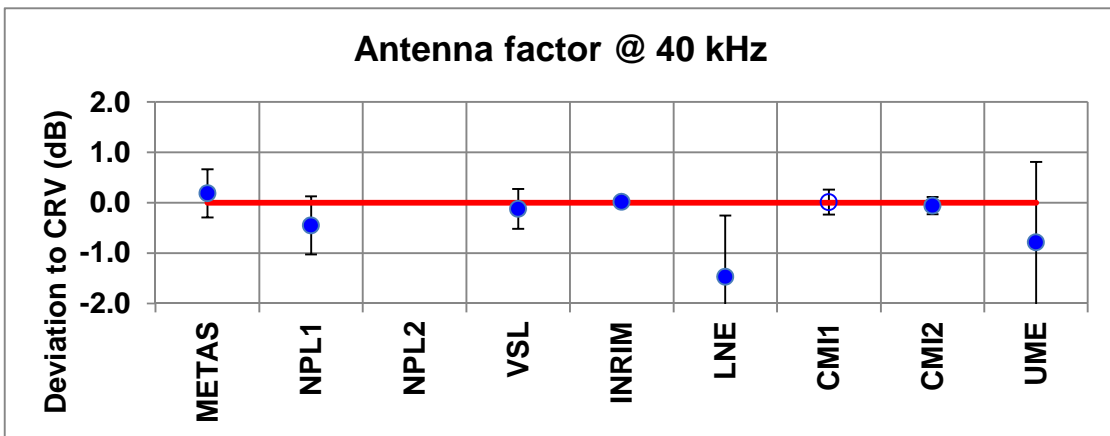
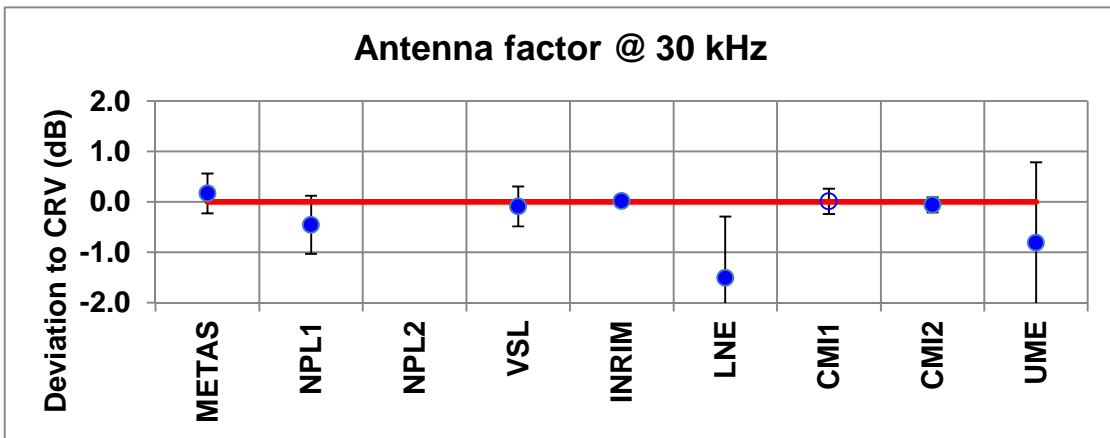
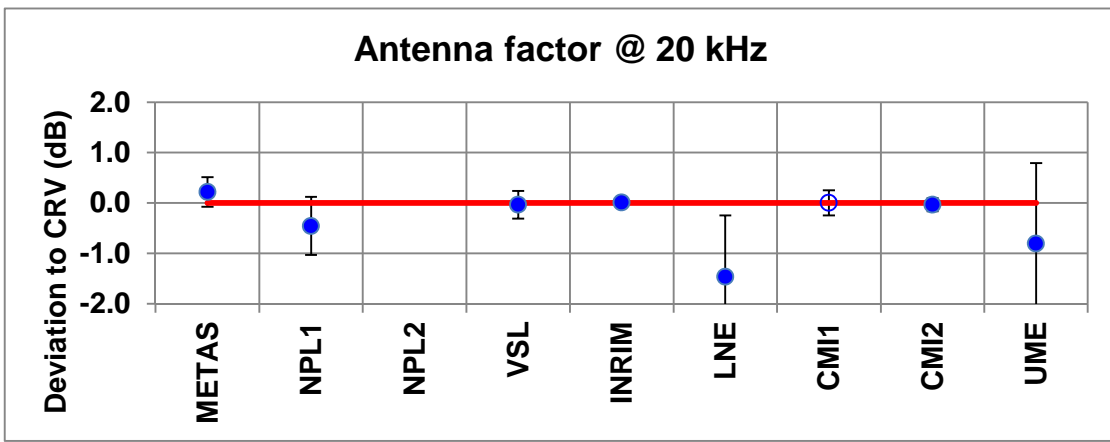
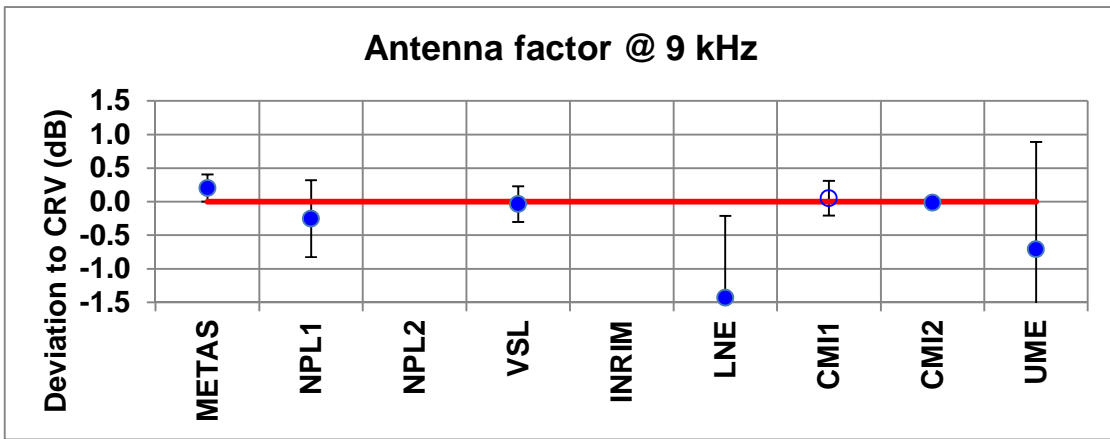

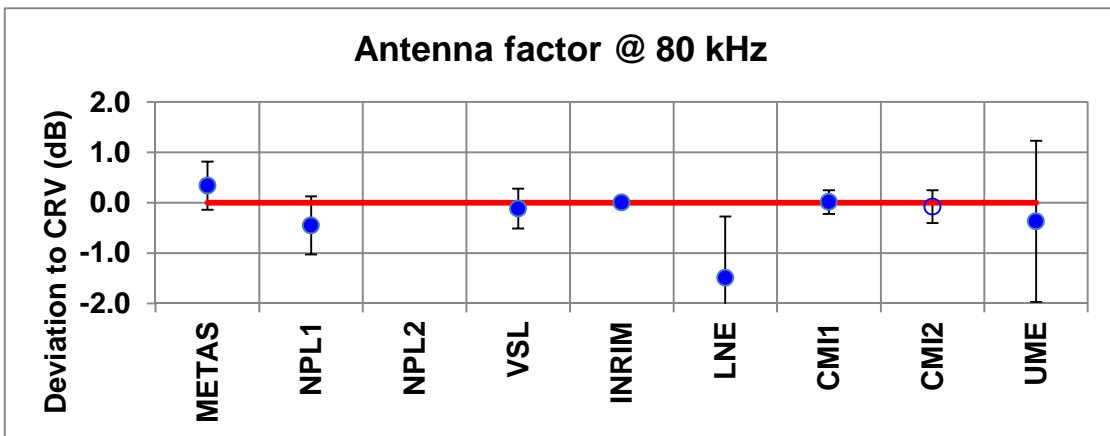
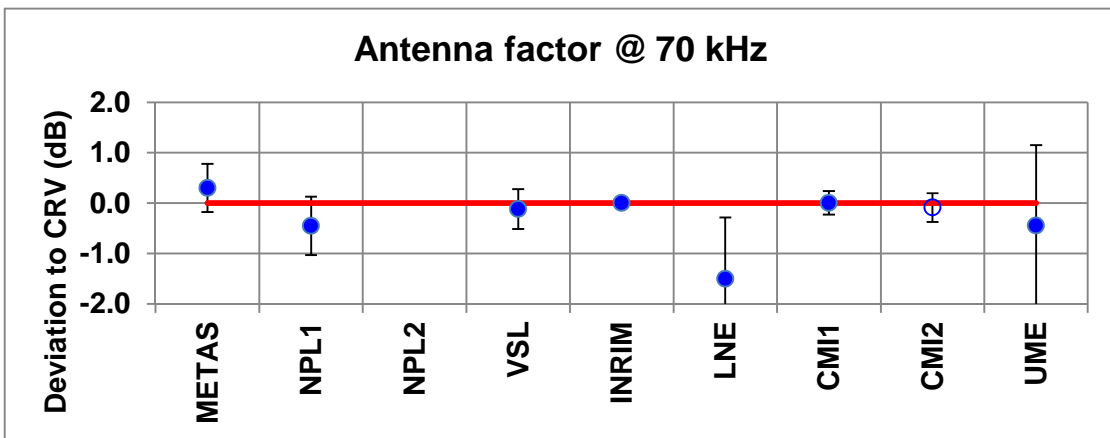
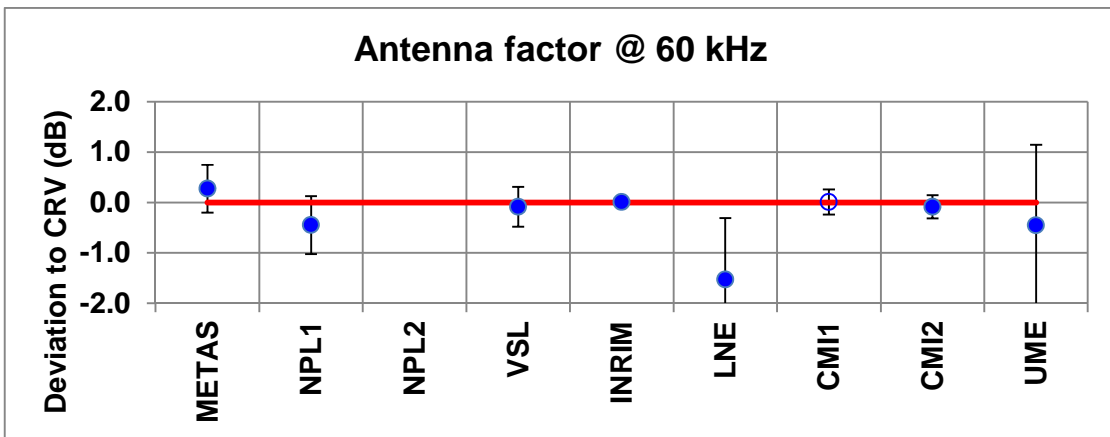
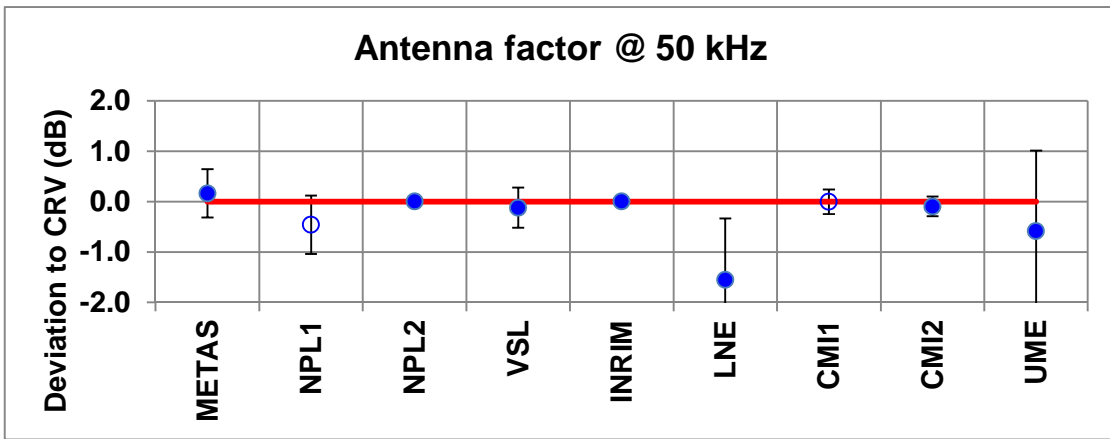

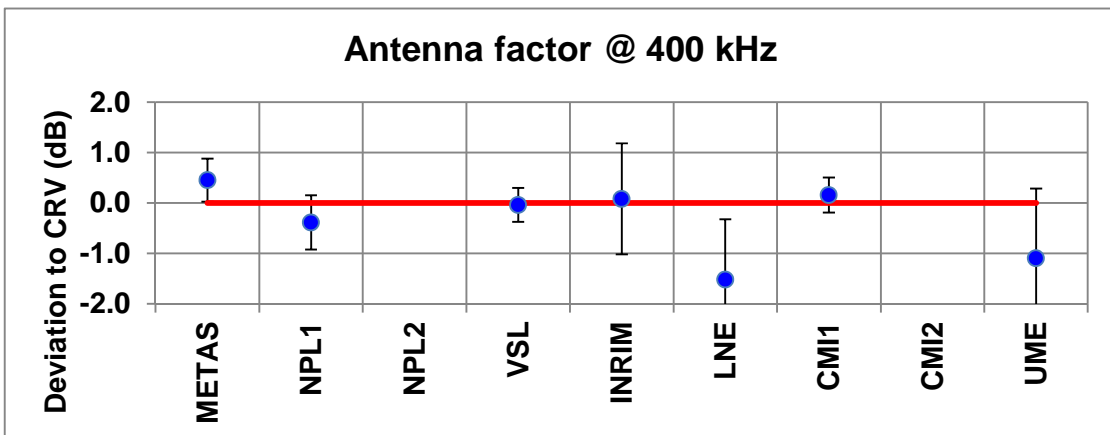
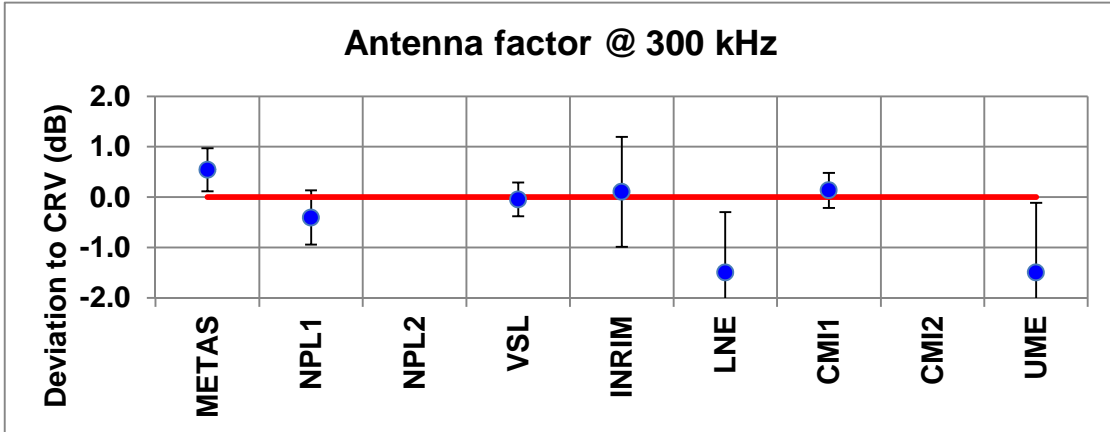
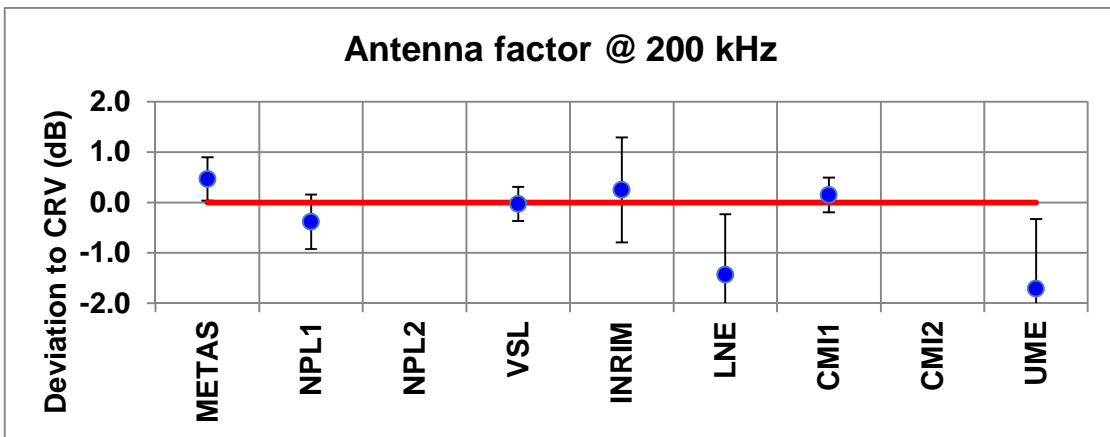
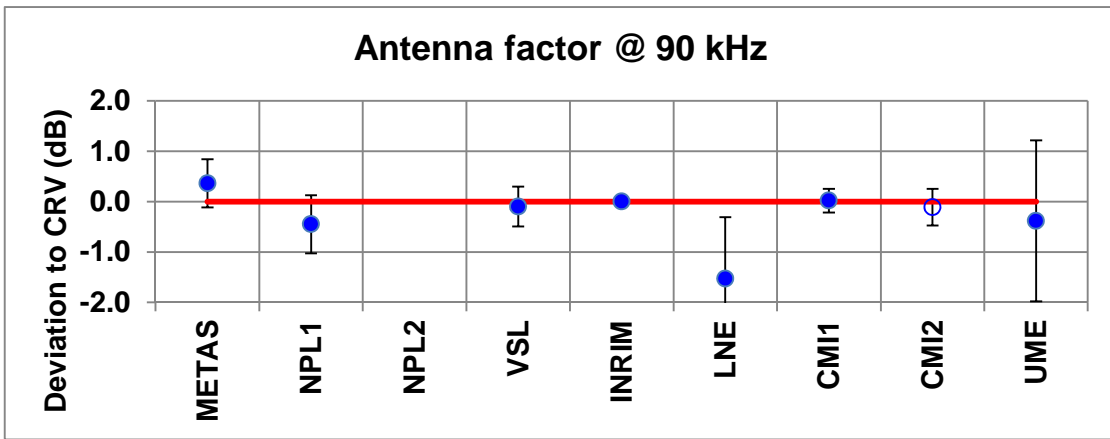

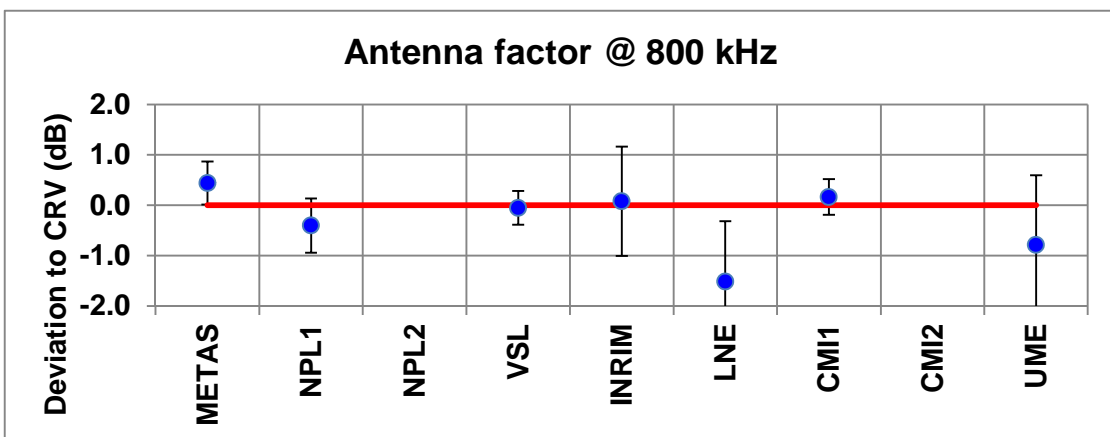
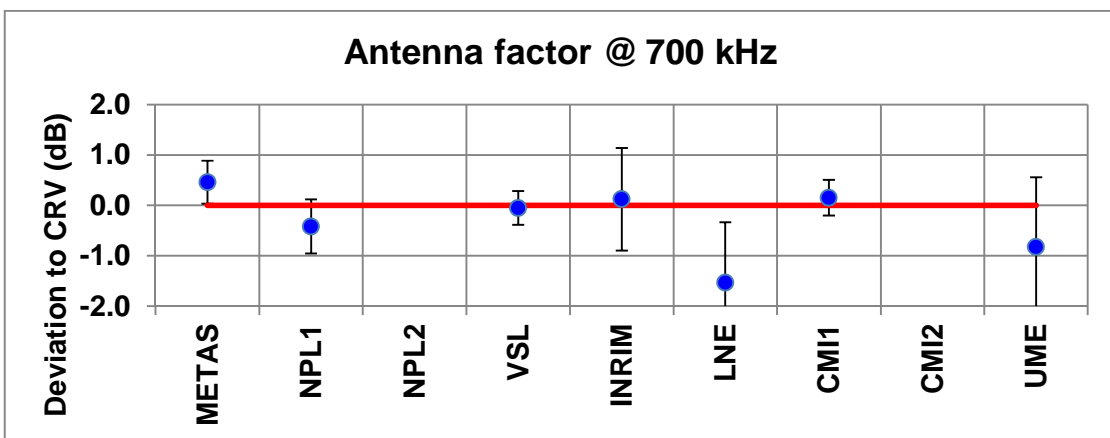
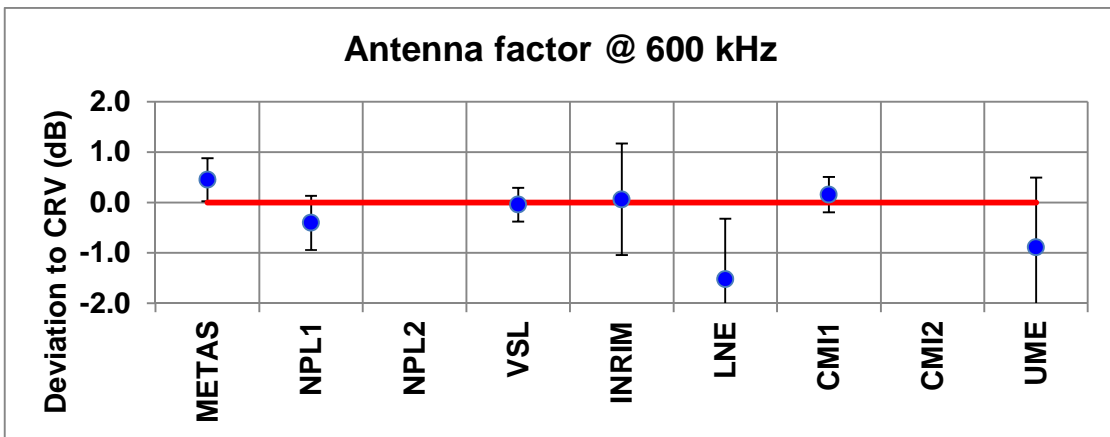
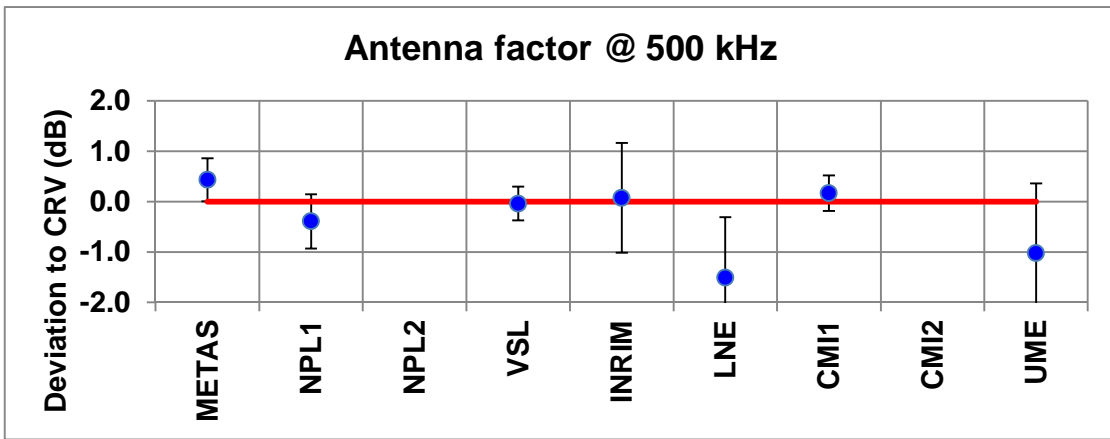

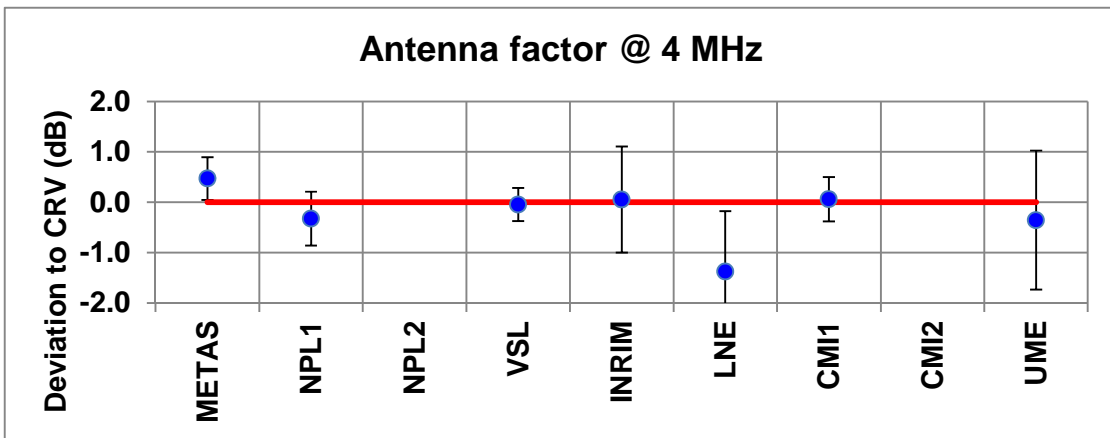
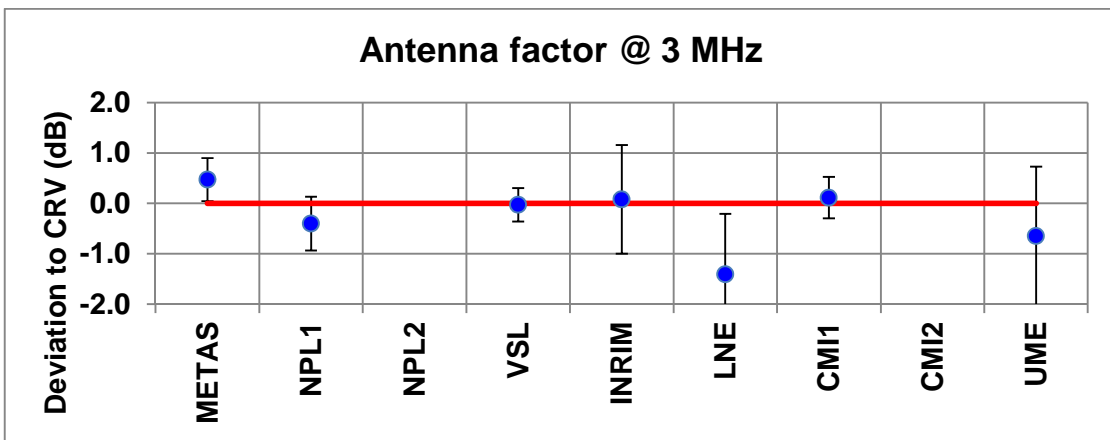
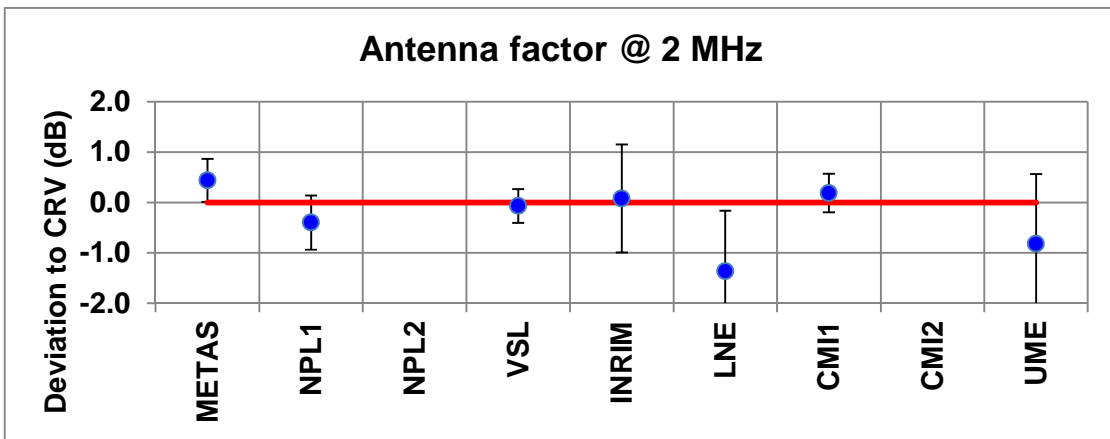
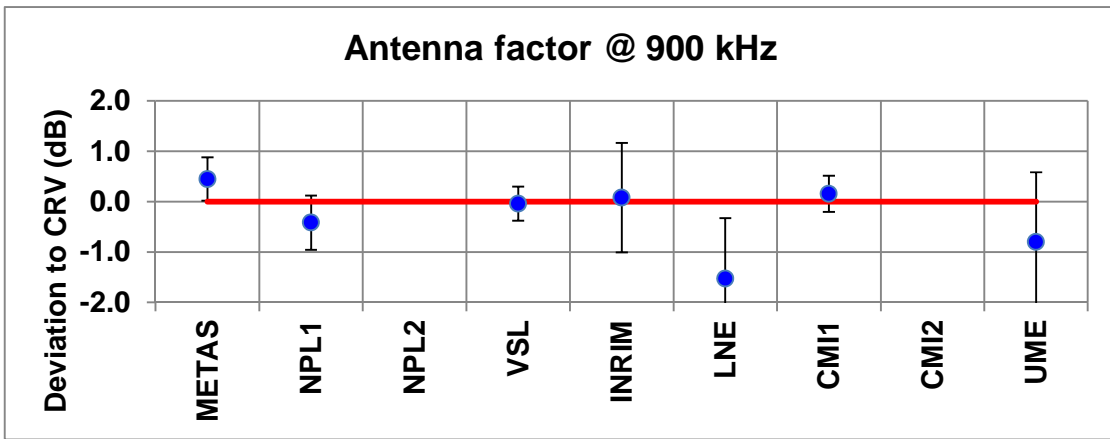

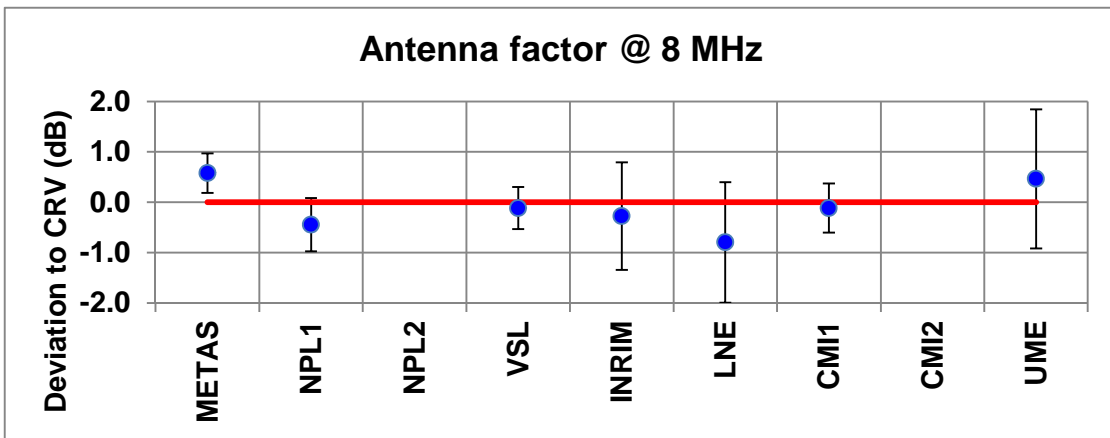
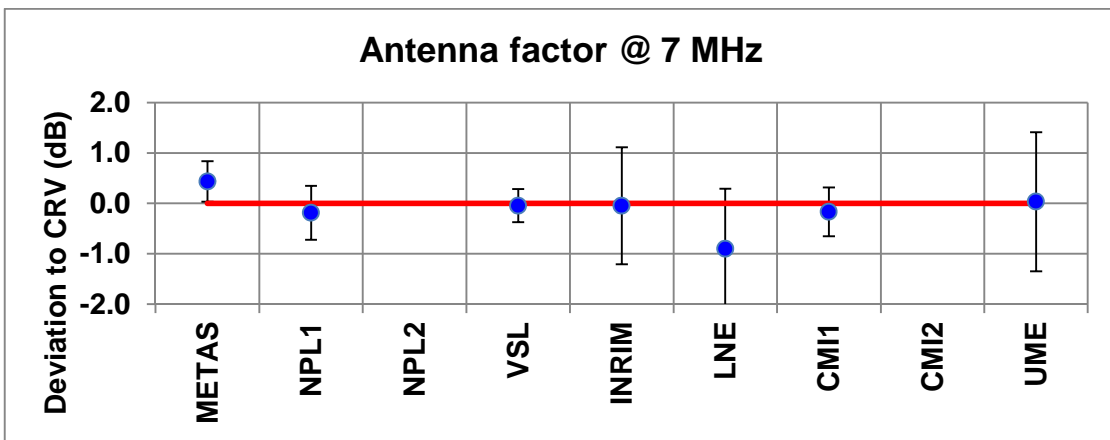
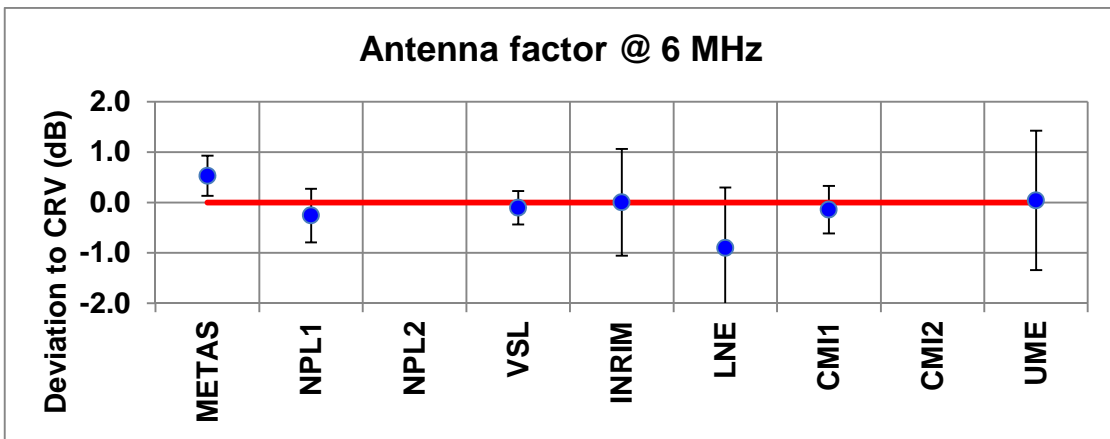
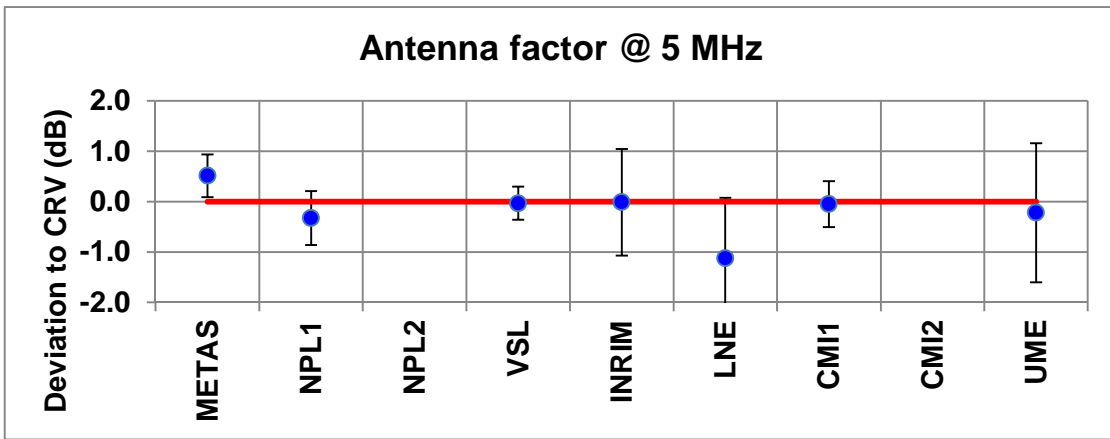

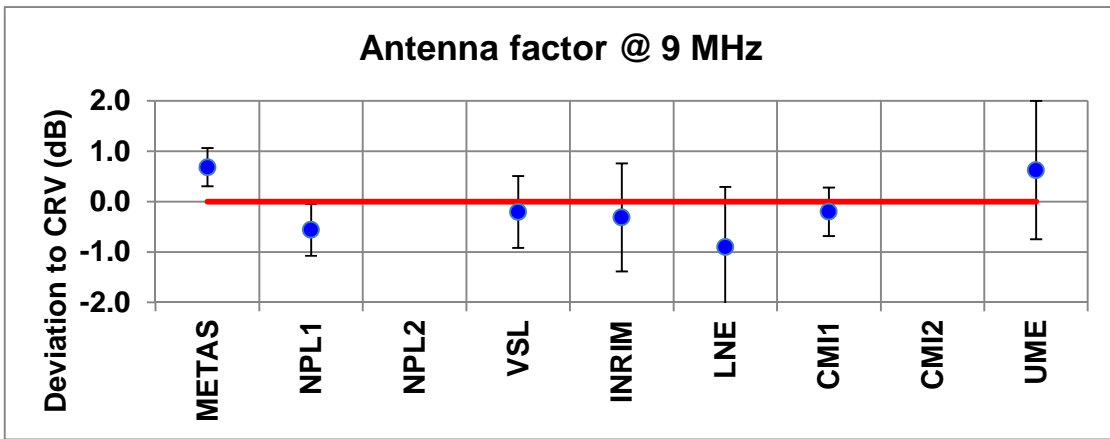

10 Annex B: Graphical S11 at mandatory frequencies

Note: Uncertainty bars are for k=2.

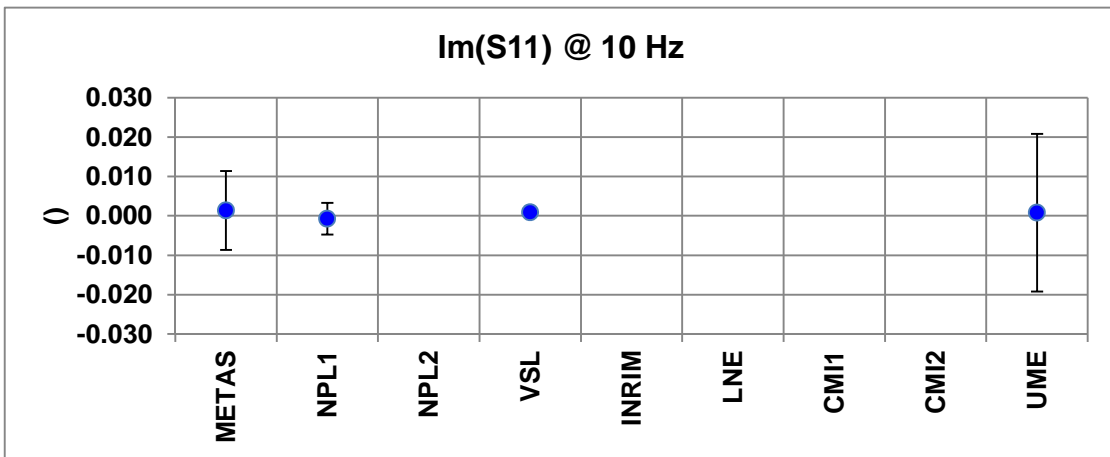
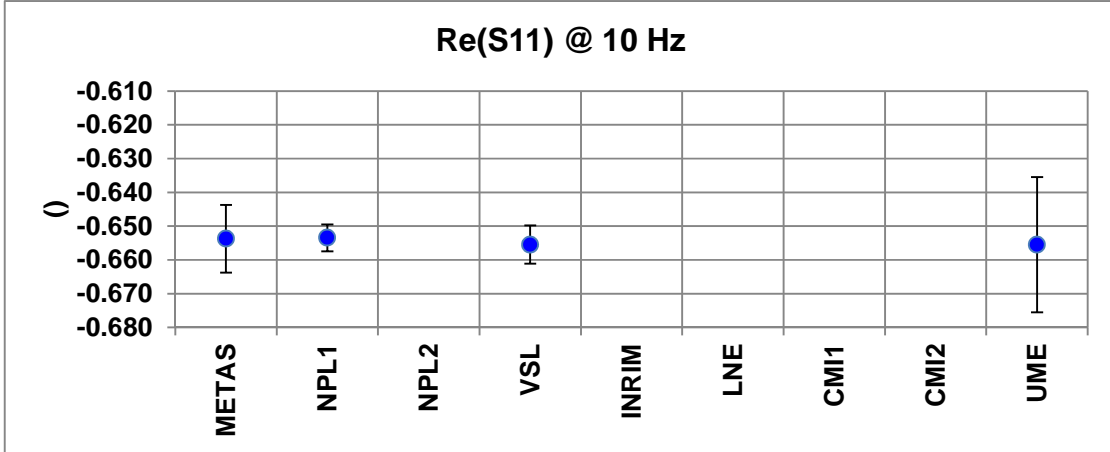

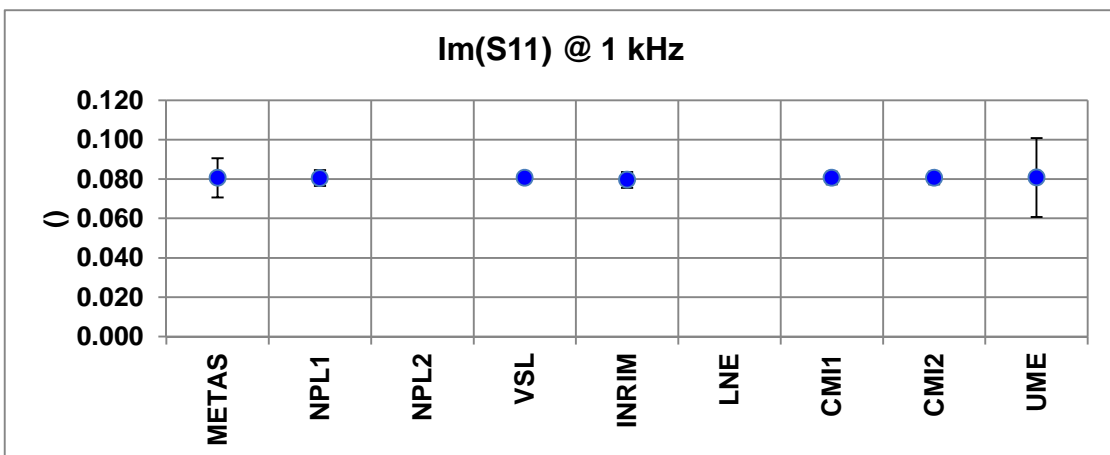
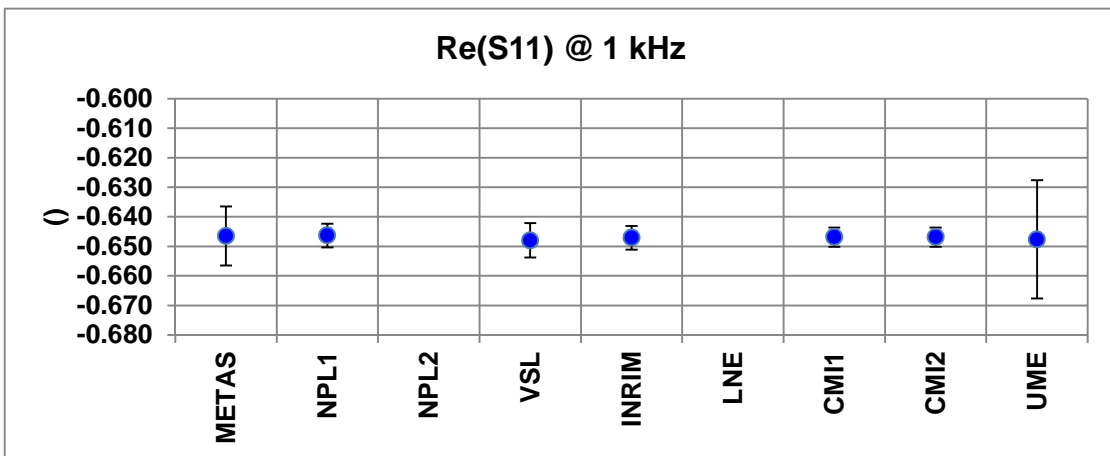
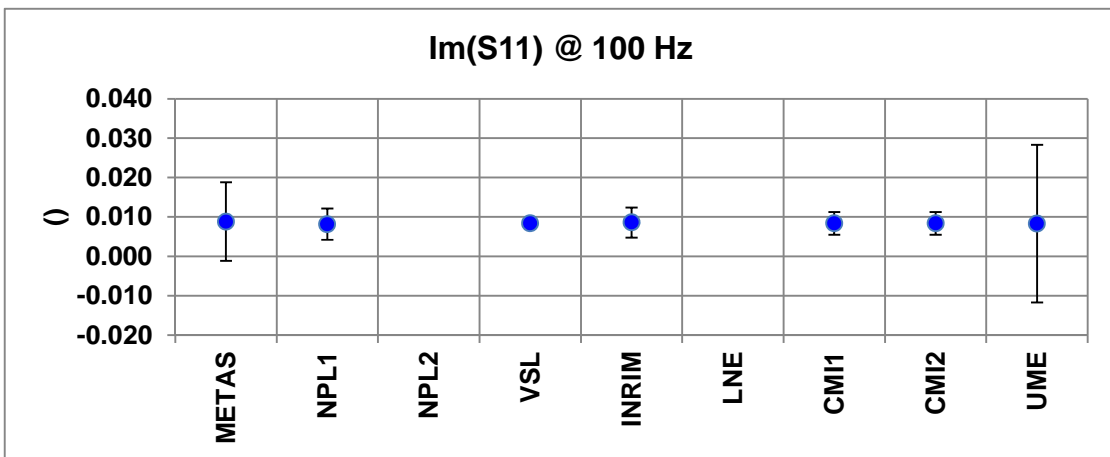
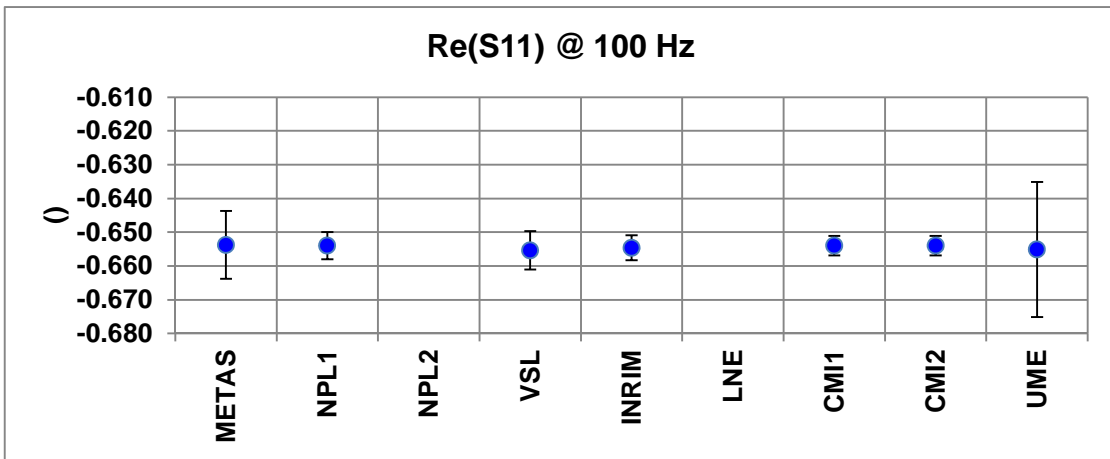

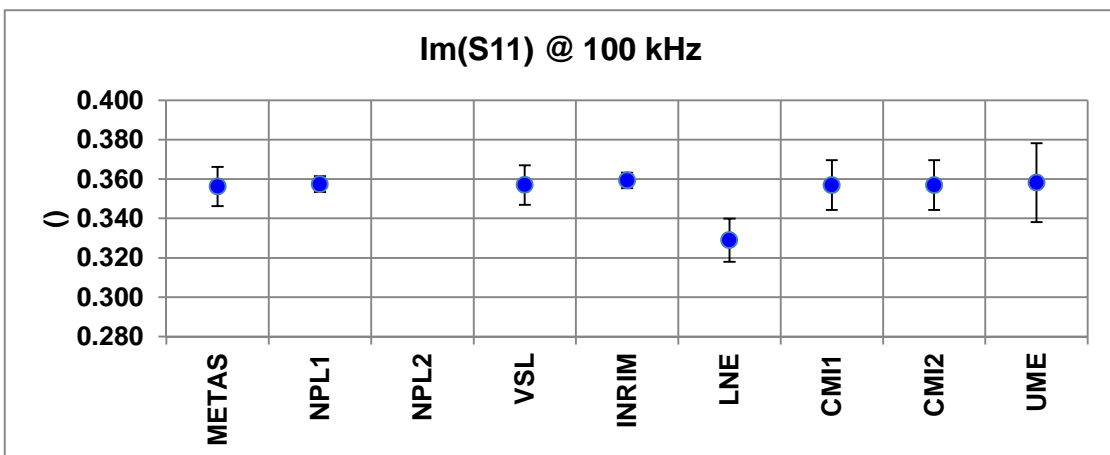
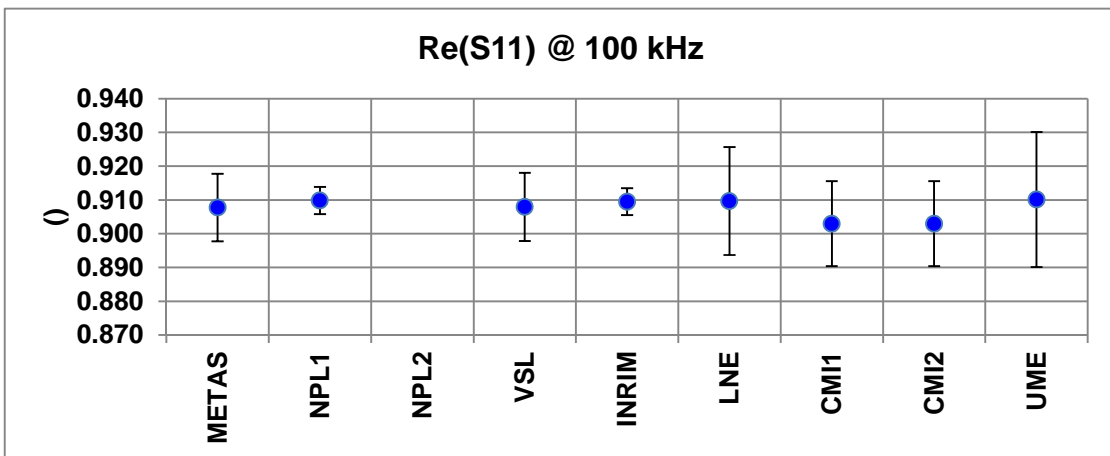
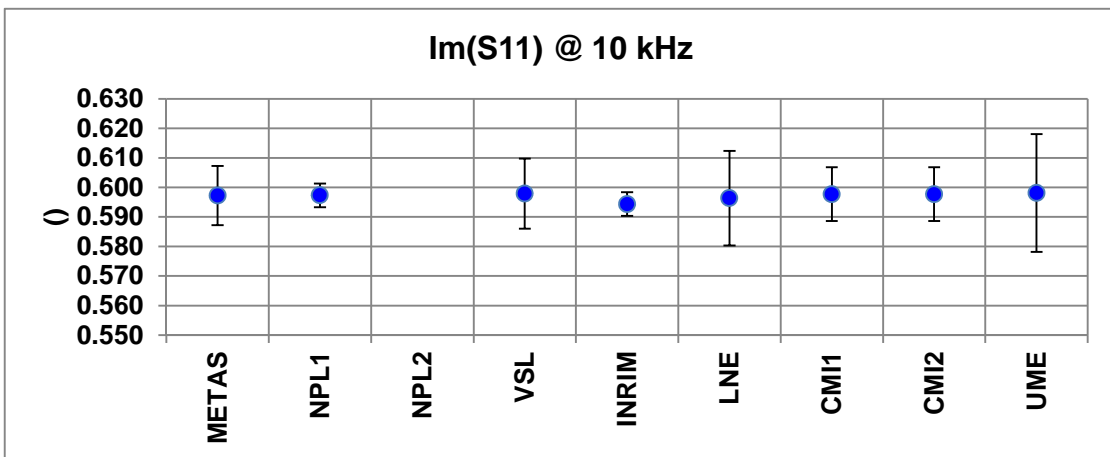
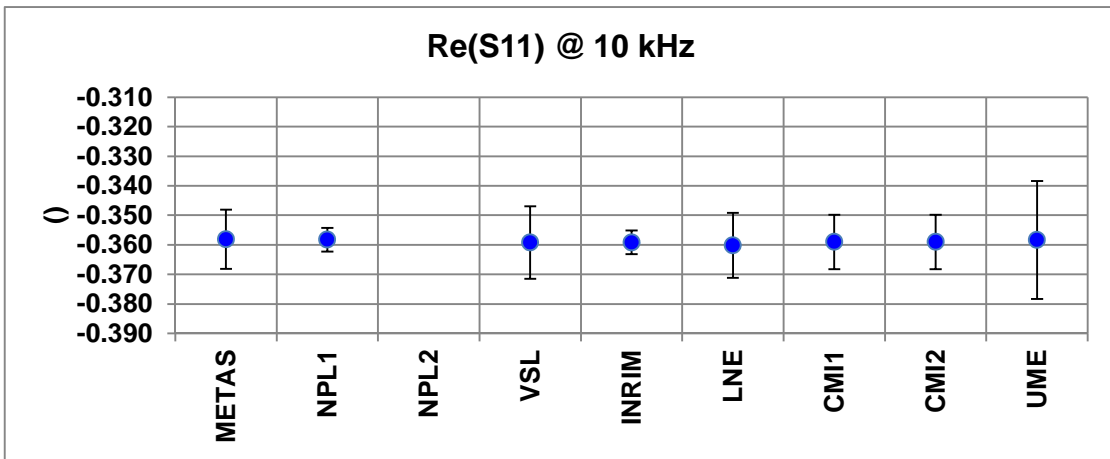

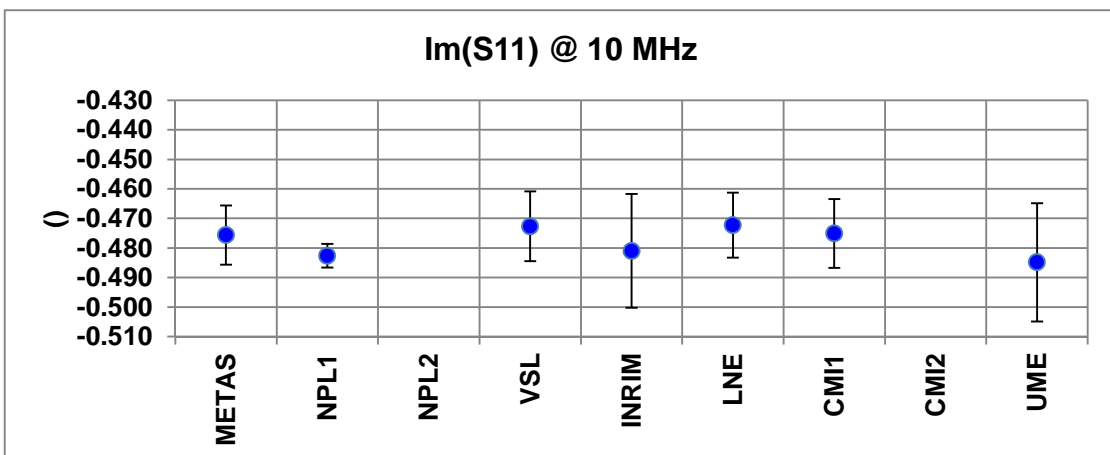
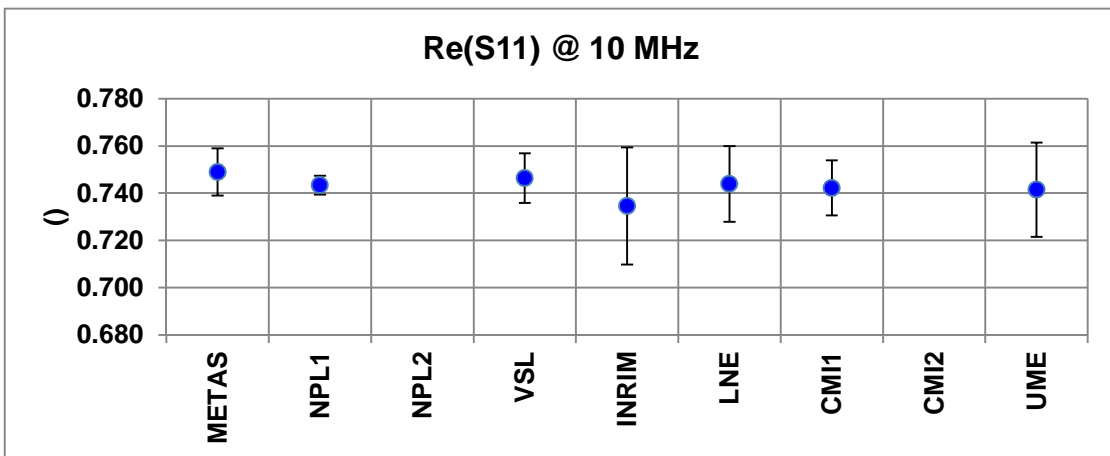
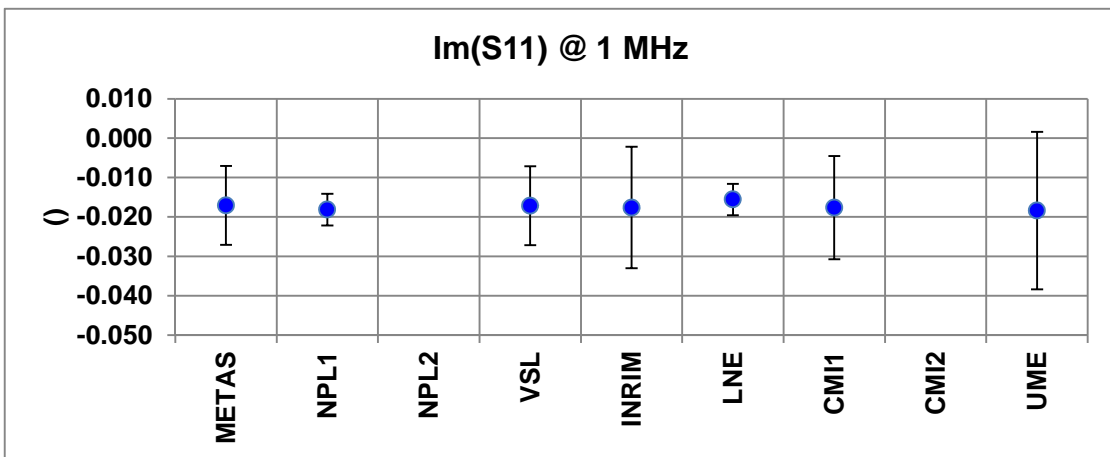
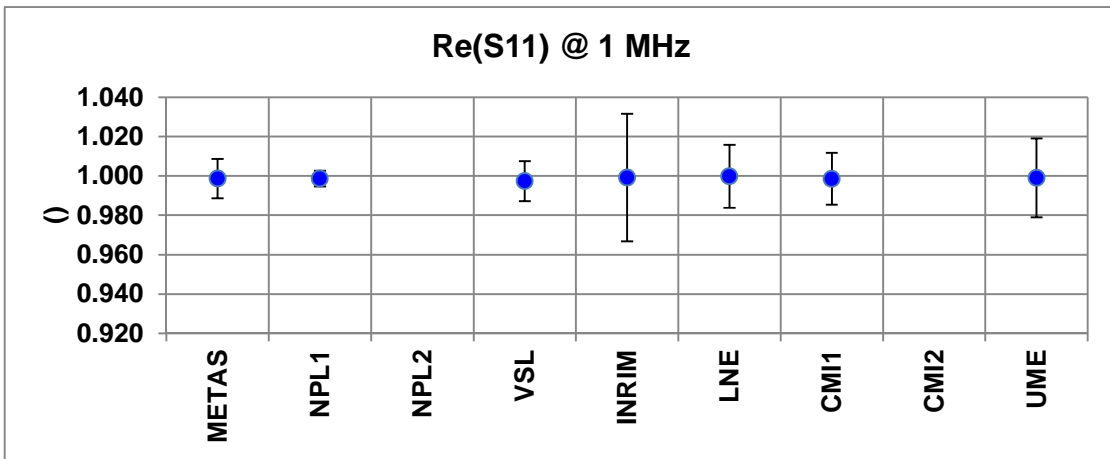

11 Annex C: Participants protocol and uncertainty budget

Are to be found hereafter in the following order

1. METAS
2. NPL1
3. NPL2
4. VSL
5. INRIM
6. LNE
7. Annex correction to LNE report
8. CMI1
9. CMI2
10. UME

EURAMET Supplementary Comparison: EURAMET.EM.RF-S27

Antenna factor for Loop Antennas

1 General Information

Laboratory Name	METAS
Author:	pyfr
Date:	21.07.2011
Laboratory Temperature range:	22-24 degrees

2 Measurements procedure

2.1 Measurement method 1 (low frequency)

2.1.1 Method

Three antenna method according to the following principle:

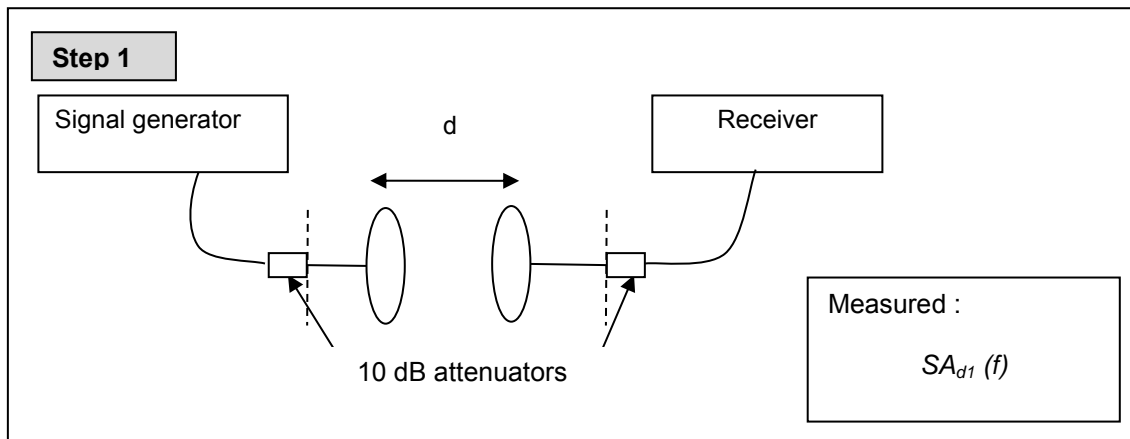

The antenna factor is obtained by using the following equations:

$$AF_1^{dB(pT / \mu V)} = \frac{(SA_{12}^{dB} + SA_{13}^{dB} - SA_{23}^{dB})}{2} - \frac{(60 \log_{10}(D_{12}^m) + 60 \log_{10}(D_{13}^m) - 60 \log_{10}(D_{23}^m) + 20 \log_{10}(f^{Hz}) - 62)}{2}$$

Where the index refers to the antenna pair 1-2, 1-3 and 2-3.

Legend:

- SA so called site attenuation (or inverse of the insertion loss)
- d is the separation distance of the phase centers
- r_1 is the radius of the first loop
- r_2 is the radius of the second loop
- $d_{eff} = \sqrt{d^2 + r_1^2 + r_2^2}$
- $D^m = \sqrt[3]{\frac{(d_{eff}^m)^3}{1 + \left(\frac{2\pi \cdot f \cdot d_{eff}}{c}\right)^2}} \cong d_{eff}$
- f is the frequency
- AF_1 is the antenna factors.
- $c = 2.9979 \cdot 10^8 \text{ m/s}$ is the speed of light

2.1.2 Small trick to measure site attenuation

The measurements should typically be performed at a distance of 1m. The measured attenuation is very important (up to 140 dB in some frequencies). As the distance dependence of the measurements is the same for all frequencies, following procedure has been developed and implemented by METAS:

In a first step, a full frequency sweep is performed at a reduced distance (typically 20 cm). The smallest attenuation is at a frequency near 20 kHz. Therefore, the measurement at one meter is performed only at 20 kHz, and the distance scaling factor is only determined at 20 kHz.

2.1.3 Measuring equipment

Device	Manufacturer	Type	Inventory
Function generator	Agilent	33220A	7133
Measuring Receiver	Rohde&Schwarz	ESS	4144
TOSM Calibration Kit N 50 Ω	Rohde&Schwarz	ZV-Z21	4112
Type-N Calibration Kit, Option 500	Agilent	85032F	5344
Magnetic Field Pickup Coil	Rohde&Schwarz	HZ-10	5265 6728

2.2 Measurement method 2 (high frequency)

2.2.1 Method

In a GTEM Cell:

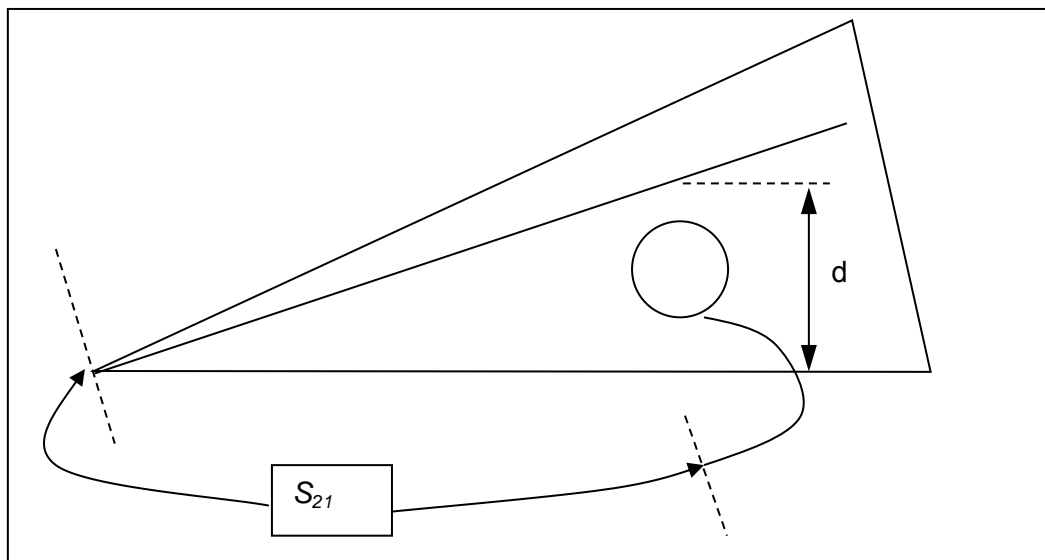

The value of the H-field in the GTEM cell is obtained as:

$$H_{GTEM}(x) = k_{H-Field}(x) \cdot \frac{\sqrt{P_1 \cdot Z_L}}{d} \cdot \frac{1}{Z_{vacuum}}$$

With

- $H_{GTEM}(x)$ the H-field in the GTEM cell at the position of the loop in A/m
- x the distance of the measuring point to the tip of the cell
- $Z_{vacuum} = 377 \Omega$ the vacuum impedance.
- $P_1 = \frac{U_1^2}{Z_L}$ input power into the GTEM cell
- U_1 the forward voltage into the GTEM cell
- Z_L the reference impedance of the cell (50 Ω)
- d the septum height
- $S_{21} \cong \frac{U_2}{U_1}$ the S21-parameter where port 1 is the input of GTEM cell and port 2 the output of the loop antenna
- U_2 the voltage measured at the loop antenna at 50 Ω .
- $k_{H-Field}(x)$ the absolute calibration factor for B-field (see below).

Out of this equation, we get the antenna factor $AF \equiv H / U_2$ of the loop antenna, expressed in (A/m/V).

$$AF [A/m/V] = \frac{1}{|S_{21}| \cdot d} \cdot \frac{1}{Z_{vacuum}}$$

2.2.2 Absolute calibration of the GTEM cell

Since the GTEM-cell is not as perfect as a TEM cell (reflections) the following semi-empirical model for the B-field has been developed: the factor $k_{H-Field}$ is the absolute calibration factor for the H-field is obtained as

$$k_{H-Field}(x) = \left| a(f) \cdot 1 - b(f) \cdot s_{GTEM}^{11} \cdot e^{2\pi i \cdot 2x \cdot f / c} \right|$$

With for the moment:

$$a(f) = b(f) = 1$$

And

- f the frequency

- c the speed of light
- S_{GTEM}^{11} the complex reflection coefficient of the GTEM cell
- $a(f)$, $b(f)$ fitting parameters. Both of these values should be 1.0 at low frequencies (10 kHz). They represent the loss of the connector making the transition from coaxial cable to the GTEM cell.
- x is the distance of the measurement place to the tip of the cell.

2.2.3 Measuring equipment

Device	Manufacturer	Type	Inventory
GTEM cell	MEB	GTEM 1750	2006
Signal generator	Rohde & Schwarz	SML 03	5250
Measuring Receiver	Rohde&Schwarz	ESS	4144
TOSM Calibration Kit N 50 Ω	Rohde&Schwarz	ZV-Z21	4112
Type-N Calibration Kit, Option 500	Agilent	85032F	5344

In order to reduce the reflections 10dB matching pad have been used.

Detailed Uncertainty budget for Antenna Factor

2.3 Frequency: 10 Hz

Uncertainty budget @ the frequency of 10 Hz						
Source of uncertainty	Type	Value	Probability distribution	k-factor	Sensitivity coefficient	Standard Uncertainty (dB)
Linearity of receiver-Signal generator	B	0.3 dB	rectangular	1.73	0.5	0.087
Linearity Kit	B	0.1 dB	normal	2.0	0.5	0.025
Mismatch Loop Antenna - Generator	B	0.11 dB	U-shape	1.4	0.86	0.068
Mismatch Loop Antenna - Receiver	B	0.11 dB	U-shape	1.4	0.86	0.068
Homogeneity – Repeteability	A	0.15 dB	normal	1.0	0.86	0.129
Distance uncertainty $60 \cdot \log_{10}(1+u(d)/d)$ With $u(d)/d=1/1000$	B	0.026 dB	rectangular	1.73	0.86	0.013
Frequency uncertainty	neglected	-	-	-	-	
Total Uncertainty (k=1)						0.185

Note: mismatch of 0.11 dB is given by 38 dB (10 dB attenuator) and 0 dB (loop antenna) return loss.

2.4 Frequency: 100 Hz

Uncertainty budget @ the frequency of 100 Hz						
Source of uncertainty	Type	Value	Probability distribution	k-factor	Sensitivity coefficient	Standard Uncertainty (dB)
Linearity of receiver-Signal generator	B	0.07 dB	rectangular	1.73	0.5	0.020
Linearity Kit	B	0.1 dB	normal	2.0	0.5	0.025
Mismatch Loop Antenna - Generator	B	0.11 dB	U-shape	1.4	0.86	0.068
Mismatch Loop Antenna - Receiver	B	0.11 dB	U-shape	1.4	0.86	0.068
Homogeneity – Repeteability	A	0.05 dB	normal	1.0	0.86	0.043
Distance uncertainty	B	0.026 dB	rectangular	1.73	0.86	0.013
Frequency uncertainty	neglected	-	-	-	-	
Total Uncertainty (k=1)						0.11

2.5 Frequency: 1 kHz

Uncertainty budget @ the frequency of 1 kHz						
Source of uncertainty	Type	Value	Probability distribution	k-factor	Sensitivity coefficient	Standard Uncertainty (dB)
Linearity of receiver-Signal generator	B	0.05 dB	rectangular	1.73	0.5	0.014
Linearity Kit	B	0.1 dB	normal	2.0	0.5	0.025
Mismatch Loop Antenna - Generator	B	0.11 dB	U-shape	1.4	0.86	0.068
Mismatch Loop Antenna - Receiver	B	0.11 dB	U-shape	1.4	0.86	0.068
Homogeneity – Repetability	A	0.05 dB	normal	1.0	0.86	0.043
Distance uncertainty	B	0.026 dB	rectangular	1.73	0.86	0.013
Frequency uncertainty	neglected	-	-	-	-	
Total Uncertainty (k=1)						0.11

2.6 Frequency: 10 kHz

Uncertainty budget @ the frequency of 10 kHz						
Source of uncertainty	Type	Value	Probability distribution	k-factor	Sensitivity coefficient	Standard Uncertainty (dB)
Linearity of receiver-Signal generator	B	0.05 dB	rectangular	1.73	0.5	0.014
Linearity Kit	B	0.1 dB	normal	2.0	0.5	0.025
Mismatch Loop Antenna - Generator	B	0.11 dB	U-shape	1.4	0.86	0.068
Mismatch Loop Antenna - Receiver	B	0.11 dB	U-shape	1.4	0.86	0.068
Homogeneity – Repetability	A	0.05 dB	normal	1.0	0.86	0.043
Distance uncertainty	B	0.026 dB	rectangular	1.73	0.86	0.013
Frequency uncertainty	neglected	-	-	-	-	
Total Uncertainty (k=1)						0.11

2.7 Frequency: 100 kHz

Uncertainty budget @ the frequency of 10 Hz						
Source of uncertainty	Type	Value	Probability distribution	k-factor	Sensitivity coefficient	Standard Uncertainty (dB)
Linearity of receiver-Signal generator	B	0.10 dB	rectangular	1.73	1.0	0.058
Linearity Kit	B	0.10 dB	normal	2.0	1.0	0.050
Mismatch Loop Antenna - Generator	B	0.22 dB	U-shape	1.4	1.0	0.157
Mismatch Loop Antenna - Receiver	B	0.11 dB	U-shape	1.4	1.0	0.079
Homogeneity – Repetability	A	0.13 dB	normal	1.0	1.0	0.130
Total Uncertainty (k=1)						0.232

Note: mismatch of 0.22 dB is given by 32 dB (Generator spec + 10 dB) and 0 dB (loop antenna) return loss.

2.8 Frequency: 1 MHz

Uncertainty budget @ the frequency of 10 Hz						
Source of uncertainty	Type	Value	Probability distribution	k-factor	Sensitivity coefficient	Standard Uncertainty (dB)
Linearity of receiver-Signal generator	B	0.10 dB	rectangular	1.73	1.0	0.058
Linearity Kit	B	0.10 dB	normal	2.0	1.0	0.050
Mismatch Loop Antenna - Generator	B	0.22 dB	U-shape	1.4	1.0	0.157
Mismatch Loop Antenna - Receiver	B	0.11 dB	U-shape	1.4	1.0	0.079
Homogeneity – Repetability	A	0.13 dB	normal	1.0	1.0	0.130
Total Uncertainty (k=1)						0.232

2.9 Frequency: 10 MHz

Uncertainty budget @ the frequency of 10 Hz						
Source of uncertainty	Type	Value	Probability distribution	k-factor	Sensitivity coefficient	Standard Uncertainty (dB)
Linearity of receiver-Signal generator	B	0.05 dB	rectangular	1.73	1.0	0.029
Linearity Kit	B	0.12 dB	normal	2.0	1.0	0.060
Mismatch Loop Antenna - Generator	B	0.22 dB	U-shape	1.4	1.0	0.157
Mismatch Loop Antenna - Receiver	B	0.11 dB	U-shape	1.4	1.0	0.079
Homogeneity – Repetability	A	0.13 dB	normal	1.0	1.0	0.130
Total Uncertainty (k=1)						0.228

EURAMET Supplementary Comparison: EURAMET.EM.RF-S27

Antenna factor for Loop Antennas

1 General Information

Laboratory Name:	National Physical Laboratory
Author:	David Gentle
Date:	16 September
Laboratory Temperature range:	23 ± 1 °C
Measurements carried out by:	Daniel Bownds & David Gentle
Dates of Measurement:	9 to 13 September 2011
Comparison Standard:	Rohde & Schwarz HZ-10 loop
Serial Number:	100149

2 Measurement procedure

2.1 General method

- 2.1.1 The HZ-10 loop antenna was positioned at the centre of a Crawford Type TEM cell (EMCO model 5106) with the plane of the loop perpendicular to the magnetic field and parallel to the direction of propagation. The separation between the septum of the TEM cell and the outer conductor was 90.8 cm.
- 2.1.2 The output from the loop was connected to the 50 Ω input of an HP89410A vector signal analyzer using a 1.5 m coaxial cable. The signal source of the HP89410A was used to set up a calculable, linearly polarised, electromagnetic field in the TEM cell, approximating to a plane wave. The relative field level was determined by connecting the output of the TEM cell to the HP89410A analyser via calibrated attenuators.
- 2.1.3 For frequencies below 10 kHz the signal input to the TEM cell was amplified using a Techron model 7790 power supply amplifier. In this case, a calibrated 40 dB high power attenuator followed by a 30 dB low power attenuator were attached to the output of the TEM cell to attenuate the signal to a level the HP89410A could measure.
- 2.1.4 For frequencies above 10 kHz, the Techron amplifier was not required and the 40 dB high power attenuator was removed, so only the 30 dB low power attenuator was used on the TEM cell output.
- 2.1.5 The setups used are shown below:

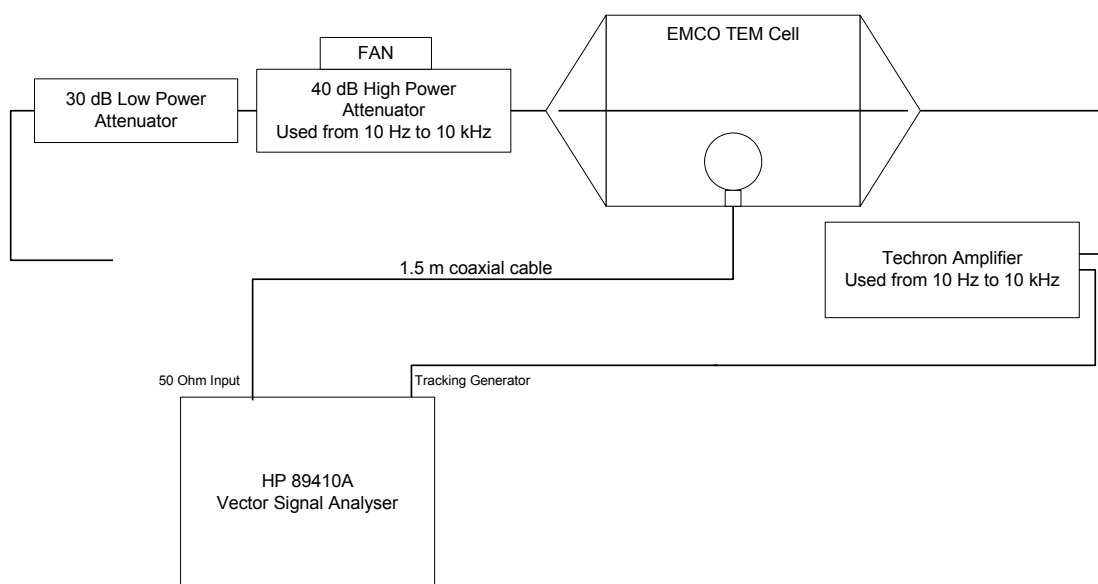

Figure 1. Equipment setup for loop measurement

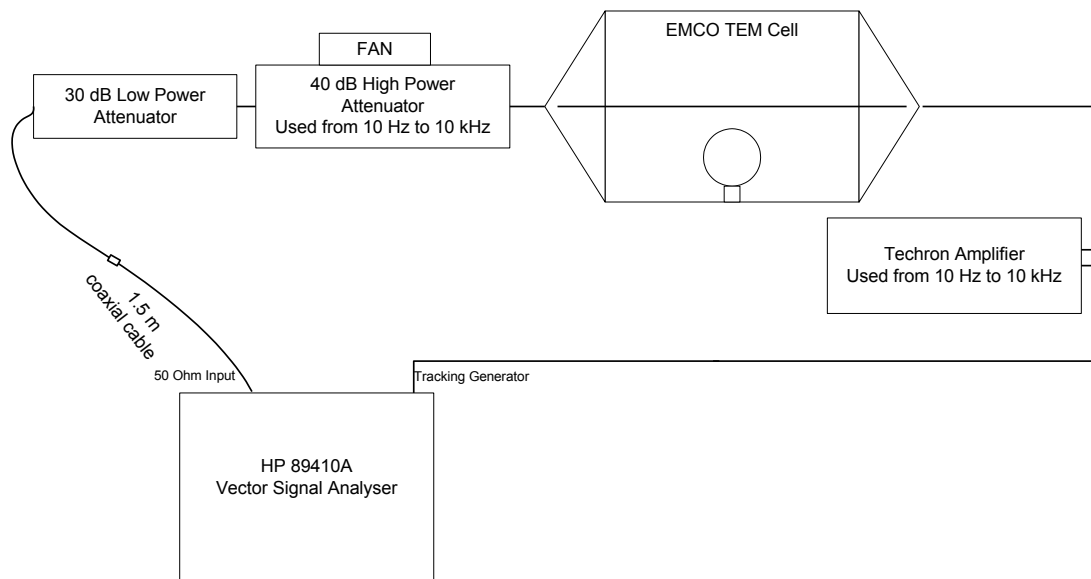

Figure 2. Equipment setup for cell measurement

- 2.1.6 The loss through the cell over the operating frequency range has been measured and shown to be insignificant.
- 2.1.7 When measuring the output from the cell (figure 2) the 1.5 m coaxial cable that was used to connect to the loop antenna during the loop measurements was connected to the short coaxial cable on the output of the attenuator so that any loss in this cable was taken into account. This 1.5 m cable was selected as the shortest cable that could be used to connect the loop to the HP89410A and whose impedance was as close to 50 Ω as possible over the operating range.

2.2 Calculation of the Magnetic Antenna Factor

- 2.2.1 The electric field Antenna Factor (AF) of a receiving antenna is the ratio between the plane wave electric field at the antenna (E_{TEM}) and the output voltage at the antenna terminals (V_{OUT}).

$$AF = \frac{E_{TEM}}{V_{OUT}} \quad (1)$$

- 2.2.2 In a TEM cell, the plane wave electric field can be calculated from the voltage applied to the cell (V_{TEM}) and the distance between the inner and outer conductor of the cell (b),

$$E_{TEM} = \frac{V_{TEM}}{b} \quad (2)$$

2.2.3 The voltage can be calculated from the impedance of the cell (Z_{Cell}) at the insertion point and the power delivered to the cell (P_{in}),

$$V_{TEM} = \sqrt{Z_{Cell} \cdot P_{in}} \quad (3)$$

and therefore

$$E_{TEM} = \frac{1}{b} \sqrt{Z_{Cell}} \sqrt{P_{in}} \quad (4)$$

2.2.4 The power delivered to the cell (P_{in}) is actually calculated by measuring the power out of the cell having the loss through the cell is negligible.

2.2.5 The second measurement, with the loop connected to the receiver, gives the power P_{OUT} . This is used to determine the output voltage at the antenna terminals

$$V_{OUT} = \sqrt{Z_R \cdot P_{OUT}} \quad (5)$$

with the impedance of the receiver Z_R , which is assumed to be 50 Ω .

2.2.6 Using Equations (4) and (5) in Equation (1) gives

$$AF = \frac{1}{b} \sqrt{\frac{Z_{Cell}}{Z_R}} \sqrt{\frac{P_{in}}{P_{OUT}}} \quad (6)$$

2.2.7 Converting Equation (6) to dB gives the electric field antenna factor:

$$AF(E)_{dB(V/m)} = P_{in(dB)} - P_{OUT(dB)} - 20 \log(b) + 10 \log\left(\frac{Z_{Cell}}{Z_R}\right) \quad (7)$$

2.2.8 Since the field in the TEM cell is assumed to be a plane wave, the ratio between the electric and the magnetic field is the wave impedance Z_0 , which is 377 Ω at high frequencies.

$$Z_0 = \frac{E}{H} \leftrightarrow H = \frac{E}{Z_0} \quad (8)$$

2.2.9 This leads to the following magnetic antenna factor in dB(S/m):

$$AF(H)_{dB(S/m)} = P_{in(dB)} - P_{OUT(dB)} - 20 \log(b) + 10 \log\left(\frac{Z_{Cell}}{Z_R}\right) - 20 \log(Z_0) \quad (9)$$

2.2.10 For passive loops at low frequencies, the signal from the loop is very low, so the power delivered to the TEM cell needs to be amplified to improve the signal to noise ratio. Additional attenuation is then required when measuring the output of the cell. Therefore, the power delivered to the cell, $P_{in(dB)}$, is the power measured in the through measurement, $P_{ref(dB)}$ plus the attenuation on the cell output, A.

$$P_{in(dB)} = P_{ref(dB)} + A_{(dB)} \quad (10)$$

- 2.2.11 The wave impedance in the cell will be very close to that of free space, 377Ω , at high frequencies, but as the frequency approaches 10 Hz the wave impedance will change, approaching 280Ω for the EMCO 5106 cell. Corrections have been applied to the measured results for the wave impedance variation for frequencies below 500 Hz. Above 500 Hz the correction is negligible.
- 2.2.12 Due to the presence of the electric field component in the TEM cell there is the possibility that this will be picked up by the loop, although it is a shielded loop, or by the connecting cable. These effects were assessed, first by rotating the loop by 180° about a vertical axis so that the H-field passed through the loop in the opposite direction. This will have the effect of introducing a relative phase change of 180° for the EMF induced in the loop from the H-field relative to any EMF induced from the E-field. It was found that this was no greater than 0.07 dB. The E-field pick-up on the connecting coaxial cable was assessed by measuring the output of the cable when the connector in the TEM cell was terminated in a matched load. There was negligible pick-up.

2.3 Measurement of Reflection Coefficients

- 2.3.1 The reflection coefficients of the loop were measured on an Agilent 4395A impedance/network analyzer using an HP 87512A reflection/transmission test set.
- 2.3.2 The Agilent 4395A was calibrated using a Type-N calibration kit and then a good quality Type-N to BNC adaptor was attached to the test port to measure the reflection coefficients of the loop. The 4395A calibration was checked first by measuring a Type-N check standard that had been calibrated by the NPL primary impedance measurement system, and then by checking the calibration at the test port, once the Type-N to BNC adaptor had been fitted, using a BNC short circuit and matched termination.

3 Results

The results of the antenna factor and reflection coefficient measurements are provided in a separate Excel spreadsheet. A graph of the antenna factor is given below.

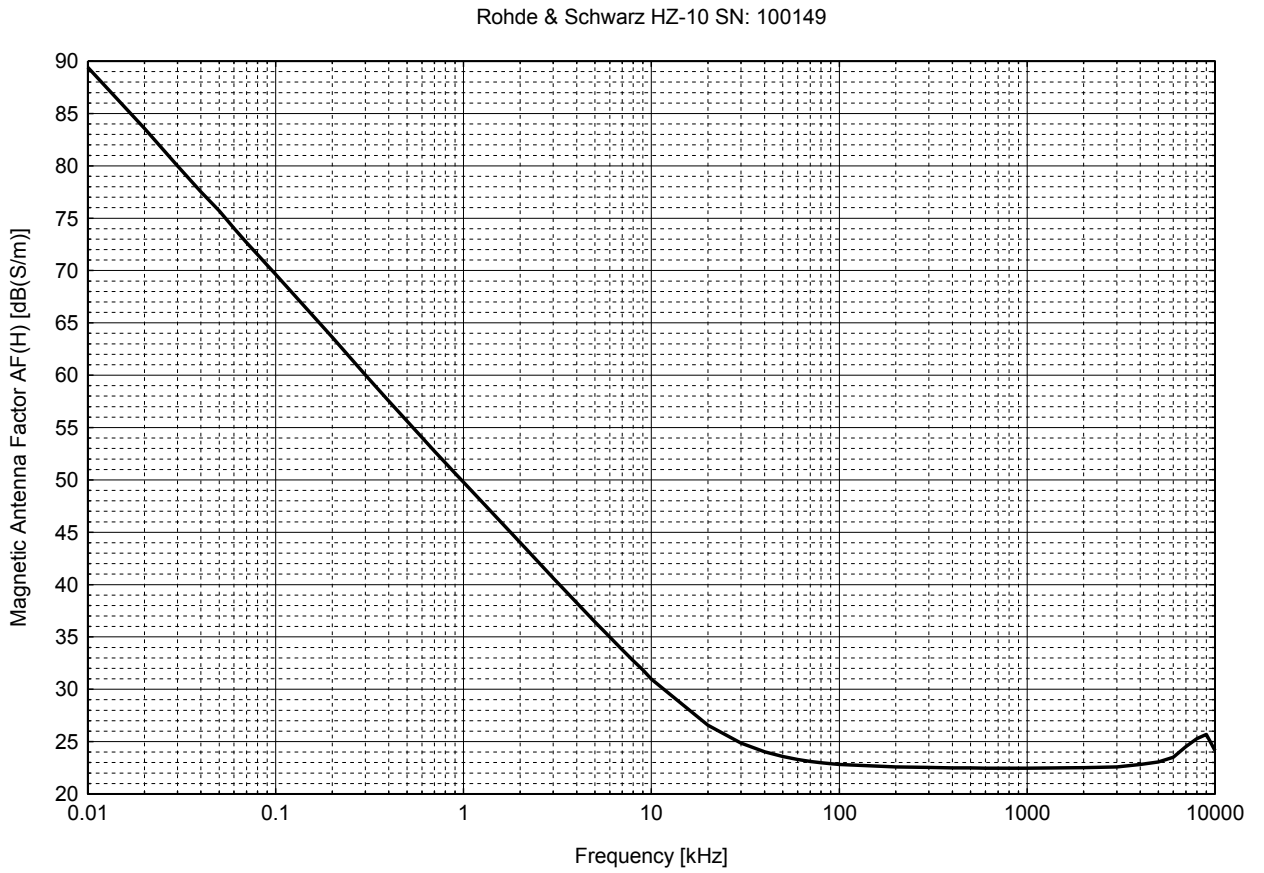

Figure 3. Magnetic Antenna Factor for HZ-10 loop

Detailed Uncertainty budget for Antenna Factor

3.1 Frequency: 10 Hz

Uncertainty budget @ the frequency of 10 Hz						
Source of uncertainty	Type	Value (dB)	Probability distribution	k-factor	Sensitivity coefficient	Standard Uncertainty (dB)
Wave impedance	B	0.30	Rectangular	1.73	1	0.173
Cell line impedance	B	0.17	Rectangular	1.73	1	0.098
Field uniformity	B	0.02	Rectangular	1.73	1	0.012
Septum height	B	0.02	Rectangular	1.73	1	0.012
Receiver sensitivity	B	0.04	Gaussian	2.00	1	0.021
Receiver linearity	B	0.16	Rectangular	1.73	1	0.092
Receiver resolution	B	0.01	Rectangular	1.73	1	0.006
System repeatability	A	0.03	Gaussian	1.00	1	0.030
Electric field rejection	B	0.07	Rectangular	1.73	1	0.042
Cable loss	B	0.05	Rectangular	1.73	1	0.029
TEM cell load reflections	B	0.34	U-shaped	1.41	1	0.241
Attenuators	B	0.06	Rectangular	1.73	1	0.035
Signal leakage	B	0.21	Rectangular	1.73	1	0.121
Mismatch (loop/receiver)	B	0.08	U-shaped	1.41	1	0.057
Mismatch (attenuator/TEM)	B	0.00	U-shaped	1.41	1	0.000
Loop positioning	B	0.10	Rectangular	1.73	1	0.058
Total Uncertainty (k=1)						0.37

3.2 Frequency: 100 Hz

Uncertainty budget @ the frequency of 100 Hz						
Source of uncertainty	Type	Value (dB)	Probability distribution	k-factor	Sensitivity coefficient	Standard Uncertainty (dB)
Wave impedance	B	0.30	Rectangular	1.73	1	0.173
Cell line impedance	B	0.17	Rectangular	1.73	1	0.098
Field uniformity	B	0.02	Rectangular	1.73	1	0.012
Septum height	B	0.02	Rectangular	1.73	1	0.012
Receiver sensitivity	B	0.01	Gaussian	2.00	1	0.005
Receiver linearity	B	0.06	Rectangular	1.73	1	0.033
Receiver resolution	B	0.01	Rectangular	1.73	1	0.006
System repeatability	A	0.03	Gaussian	1.00	1	0.030
Electric field rejection	B	0.07	Rectangular	1.73	1	0.042
Cable loss	B	0.05	Rectangular	1.73	1	0.029
TEM cell load reflections	B	0.34	U-shaped	1.41	1	0.241
Attenuators	B	0.06	Rectangular	1.73	1	0.035
Signal leakage	B	0.21	Rectangular	1.73	1	0.121
Mismatch (loop/receiver)	B	0.08	U-shaped	1.41	1	0.057
Mismatch (attenuator/TEM)	B	0.00	U-shaped	1.41	1	0.000
Loop positioning	B	0.10	Rectangular	1.73	1	0.058
Total Uncertainty (k=1)						0.36

3.3 Frequency: 1 kHz

Uncertainty budget @ the frequency of 1 kHz						
Source of uncertainty	Type	Value (dB)	Probability distribution	k-factor	Sensitivity coefficient	Standard Uncertainty (dB)
Wave impedance	B	0.00	Rectangular	1.73	1	0.000
Cell line impedance	B	0.17	Rectangular	1.73	1	0.098
Field uniformity	B	0.02	Rectangular	1.73	1	0.012
Septum height	B	0.02	Rectangular	1.73	1	0.012
Receiver sensitivity	B	0.00	Gaussian	2.00	1	0.001
Receiver linearity	B	0.06	Rectangular	1.73	1	0.033
Receiver resolution	B	0.01	Rectangular	1.73	1	0.006
System repeatability	A	0.01	Gaussian	1.00	1	0.014
Electric field rejection	B	0.07	Rectangular	1.73	1	0.042
Cable loss	B	0.05	Rectangular	1.73	1	0.029
TEM cell load reflections	B	0.34	U-shaped	1.41	1	0.241
Attenuators	B	0.06	Rectangular	1.73	1	0.035
Signal leakage	B	0.20	Rectangular	1.73	1	0.115
Mismatch (loop/receiver)	B	0.08	U-shaped	1.41	1	0.057
Mismatch (attenuator/TEM)	B	0.00	U-shaped	1.41	1	0.000
Loop positioning	B	0.10	Rectangular	1.73	1	0.058
Total Uncertainty (k=1)						0.31

3.4 Frequency: 10 kHz

Uncertainty budget @ the frequency of 10 kHz						
Source of uncertainty	Type	Value (dB)	Probability distribution	k-factor	Sensitivity coefficient	Standard Uncertainty (dB)
Wave impedance	B	0.00	Rectangular	1.73	1	0.000
Cell line impedance	B	0.17	Rectangular	1.73	1	0.098
Field uniformity	B	0.02	Rectangular	1.73	1	0.012
Septum height	B	0.02	Rectangular	1.73	1	0.012
Receiver sensitivity	B	0.00	Gaussian	2.00	1	0.001
Receiver linearity	B	0.06	Rectangular	1.73	1	0.033
Receiver resolution	B	0.01	Rectangular	1.73	1	0.006
System repeatability	A	0.00	Gaussian	1.00	1	0.004
Electric field rejection	B	0.07	Rectangular	1.73	1	0.042
Cable loss	B	0.05	Rectangular	1.73	1	0.029
TEM cell load reflections	B	0.34	U-shaped	1.41	1	0.241
Attenuators	B	0.06	Rectangular	1.73	1	0.035
Signal leakage	B	0.08	Rectangular	1.73	1	0.046
Mismatch (loop/receiver)	B	0.09	U-shaped	1.41	1	0.064
Mismatch (attenuator/TEM)	B	0.00	U-shaped	1.41	1	0.000
Loop positioning	B	0.10	Rectangular	1.73	1	0.058
Total Uncertainty (k=1)						0.29

3.5 Frequency: 100 kHz

Uncertainty budget @ the frequency of 100 kHz						
Source of uncertainty	Type	Value (dB)	Probability distribution	k-factor	Sensitivity coefficient	Standard Uncertainty (dB)
Wave impedance	B	0.00	Rectangular	1.73	1	0.000
Cell line impedance	B	0.17	Rectangular	1.73	1	0.098
Field uniformity	B	0.02	Rectangular	1.73	1	0.012
Septum height	B	0.02	Rectangular	1.73	1	0.012
Receiver sensitivity	B	0.00	Gaussian	2.00	1	0.001
Receiver linearity	B	0.06	Rectangular	1.73	1	0.033
Receiver resolution	B	0.01	Rectangular	1.73	1	0.006
System repeatability	A	0.00	Gaussian	1.00	1	0.002
Electric field rejection	B	0.07	Rectangular	1.73	1	0.042
Cable loss	B	0.05	Rectangular	1.73	1	0.029
TEM cell load reflections	B	0.34	U-shaped	1.41	1	0.241
Attenuators	B	0.03	Rectangular	1.73	1	0.017
Signal leakage	B	0.00	Rectangular	1.73	1	0.000
Mismatch (loop/receiver)	B	0.13	U-shaped	1.41	1	0.092
Mismatch (attenuator/TEM)	B	0.00	U-shaped	1.41	1	0.000
Loop positioning	B	0.10	Rectangular	1.73	1	0.058
Total Uncertainty (k=1)						0.29

3.6 Frequency: 1 MHz

Uncertainty budget @ the frequency of 1 MHz						
Source of uncertainty	Type	Value (dB)	Probability distribution	k-factor	Sensitivity coefficient	Standard Uncertainty (dB)
Wave impedance	B	0.00	Rectangular	1.73	1	0.000
Cell line impedance	B	0.17	Rectangular	1.73	1	0.098
Field uniformity	B	0.02	Rectangular	1.73	1	0.012
Septum height	B	0.02	Rectangular	1.73	1	0.012
Receiver sensitivity	B	0.00	Gaussian	2.00	1	0.001
Receiver linearity	B	0.06	Rectangular	1.73	1	0.033
Receiver resolution	B	0.01	Rectangular	1.73	1	0.006
System repeatability	A	0.01	Gaussian	1.00	1	0.006
Electric field rejection	B	0.07	Rectangular	1.73	1	0.042
Cable loss	B	0.05	Rectangular	1.73	1	0.029
TEM cell load reflections	B	0.34	U-shaped	1.41	1	0.241
Attenuators	B	0.03	Rectangular	1.73	1	0.017
Signal leakage	B	0.00	Rectangular	1.73	1	0.000
Mismatch (loop/receiver)	B	0.13	U-shaped	1.41	1	0.092
Mismatch (attenuator/TEM)	B	0.00	U-shaped	1.41	1	0.000
Loop positioning	B	0.10	Rectangular	1.73	1	0.058
Total Uncertainty (k=1)						0.29

3.7 Frequency: 10 MHz

Uncertainty budget @ the frequency of 10 MHz						
Source of uncertainty	Type	Value (dB)	Probability distribution	k-factor	Sensitivity coefficient	Standard Uncertainty (dB)
Wave impedance	B	0.00	Rectangular	1.73	1	0.000
Cell line impedance	B	0.17	Rectangular	1.73	1	0.098
Field uniformity	B	0.02	Rectangular	1.73	1	0.012
Septum height	B	0.02	Rectangular	1.73	1	0.012
Receiver sensitivity	B	0.00	Gaussian	2.00	1	0.001
Receiver linearity	B	0.06	Rectangular	1.73	1	0.033
Receiver resolution	B	0.01	Rectangular	1.73	1	0.006
System repeatability	A	0.01	Gaussian	1.00	1	0.008
Electric field rejection	B	0.07	Rectangular	1.73	1	0.042
Cable loss	B	0.05	Rectangular	1.73	1	0.029
TEM cell load reflections	B	0.34	U-shaped	1.41	1	0.241
Attenuators	B	0.03	Rectangular	1.73	1	0.017
Signal leakage	B	0.00	Rectangular	1.73	1	0.000
Mismatch (loop/receiver)	B	0.12	U-shaped	1.41	1	0.085
Mismatch (attenuator/TEM)	B	0.00	U-shaped	1.41	1	0.000
Loop positioning	B	0.10	Rectangular	1.73	1	0.058
Total Uncertainty (k=1)						0.29

EURAMET Supplementary Comparison: EURAMET.EM.RF-S27

Antenna factor for Loop Antennas

Helmholtz coil method for frequencies over the range 10 Hz to 120 kHz

1 General Information

Laboratory Name:	National Physical Laboratory Hampton Road Teddington TW11 0LW United Kingdom
Author:	Stuart Harmon
Report date:	1 November 2011
Laboratory ambient temperature:	20 ± 1 °C
Measurements carried out by:	Stuart Harmon
Dates of measurement:	19 to 20 September 2011
Comparison standard:	
Make:	Rohde & Schwarz
Mode:	HZ-10 magnetic field pickup coil
Serial Number:	100149

2 Measurements procedure

2.1 General method 1

- 2.1.1 The following procedure describes the determination of the free field antenna factor for a Rohde & Schwarz HZ-10 magnetic field pickup coil using a Helmholtz coil system.
- 2.1.2 The magnetic field pickup coil was positioned in a region of uniform magnetic field at the centre of a calibrated Helmholtz coil system. The pickup coil was aligned such that its output voltage indicated the maximum value of the magnetic flux density.
- 2.1.3 The current in the coil system was adjusted to produce a range of magnetic flux densities at various frequencies. The current waveform was sinusoidal.
- 2.1.4 The voltage induced in the pickup coil was measured for a $50\ \Omega$ load at a series of frequencies in the range 10 Hz to 120 kHz and the actual values of magnetic flux density were calculated from the measured currents.
- 2.1.5 The measurements were made at an ambient temperature of $20 \pm 1\ ^\circ\text{C}$.
- 2.1.6 The measurement setup is shown below:

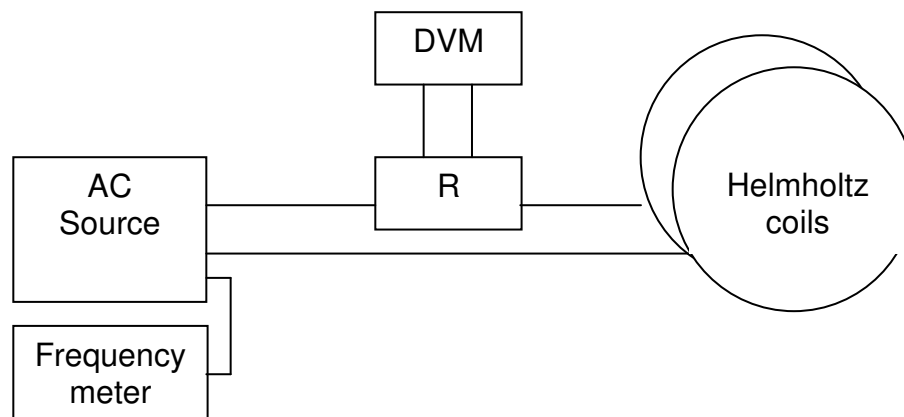

Figure 1. Equipment setup for pickup coil measurement

- 2.1.7 The determination of the Helmholtz coils magnetic field strength to current ratio (H/I) has been determined from DC to 120 kHz. The DC H/I is determined using a proton resonance magnetometer to measure the magnetic field at the centre of the Helmholtz coils whilst the current flowing in the coils is measured using a calibrated standard resistor and calibrated digital multimeter (DMM). The DC calibration is performed whilst the Helmholtz coil system is located inside a triaxial cancellation system where the magnitude and variations in the Earth's magnetic field have been reduced to an insignificant level. The frequency response is

characterized using a single turn search coil, with no frequency dependency, up to a frequency of 120 kHz.

- 2.1.8 The current in the Helmholtz coils during the characterization of the frequency response and for the measurement of the induced voltage of the HZ-10 magnetic field pickup coil is measured using a range of current shunts and calibrated DMM's. The calibration of each current shunt includes a determination of its DC value and a measurement of the AC/DC transfer difference at various frequencies over the operating range.
- 2.1.9 Traceability to the SI for the measurements detailed in this report are obtained from standards realized and maintained by NPL, and include:
- frequency
 - resistance via the quantized Hall effect
 - voltage via the Josephson effect
 - AC/DC transfer standards for current and voltage
- 2.1.10 All measurements are covered by United Kingdom Accreditation Service (UKAS) accreditation in accordance with ISO/IEC 17025:2005 'General requirements for the competence of testing and calibration laboratories'.

2.2 Calculation of the Magnetic Antenna Factor

- 2.2.1 The magnetic Antenna Factor, $AF(H)$, is defined by the ratio of the magnetic field strength, H , to output voltage, U , across a conventional 50Ω load:

$$AF = 20 \cdot \log_{10} \left(\frac{H}{U} \right) \quad (1)$$

Where:

$AF(H)$ is measured in dB(S/m)

H is measured in A/m

U is measured in V

- 2.2.2 The free field antenna factor when expressed in dB(pT/ μ V) has the following conversion applied.

$$AF_{(pT/\mu V)} = \mu_0 \cdot 10^6 \cdot AF_{(S/m)} \quad (2)$$

or

$$AF_{(dB(pT/\mu V))} = 1.984 + AF_{(dB(S/m))} \quad (3)$$

Where:

$\mu_0 = 4\pi \cdot 10^{-7}$ H/m

2.2.3 The appropriate magnetic flux density generated by the Helmholtz coil system was set so that the pickup coil output voltage had sufficient resolution so that uncertainty contributions such as DMM offsets were insignificant and DMM errors were greatly reduced. The magnetic flux densities required for the calibration of the pickup coil ranged from 1.9 mT at 10 Hz to 2.7 μ T at 120 kHz.

2.2.4 During the measurements, the corresponding current shunt voltage and pickup coil output voltage at various frequencies were recorded. Where required, corrections were made to the measured voltages to account for DMM errors and loading of the input impedance of the DMM's. At higher frequencies it is possible that the loading of the input impedance of the DMM will affect the pickup coil output voltage and the output voltage of the shunt resistor. To estimate this effect, a second similar DMM is connected in parallel with the first DMM and readings taken with one, then two DMM's in parallel. From the two readings, it is possible to calculate the value corrected for the loading of the input impedance from the relationship:

$$V_C = \frac{V_{c1}V_{c2}}{2V_{c2} - V_{c1}} \quad (4)$$

Where:

V_C is the corrected voltage in V

V_{C1} is the measured voltage using one DMM in V

V_{C2} is the measured voltage using two DMM's in V

2.2.5 The current, in A, flowing in the Helmholtz coil is determined from:

$$I = \frac{V_{shunt}}{R_{shunt}} \quad (5)$$

Where:

R_{shunt} is the resistance of the current shunt at the measured frequency, i.e. corrected for the frequency response in Ω .

2.2.6 The magnetic flux density, B, at the centre of the Helmholtz coil system is then determined from the following:

$$B = \mu_0 \left(\frac{H}{I} \times I \right) \quad (6)$$

Where:

B is measured in T

H/I is the magnetic field strength to current ratio in A/m/A, at the specific frequency

2.2.7 From the calculated magnetic flux density and corrected pickup coil output voltage at each frequency, the pickup coil sensitivity in dB(ρ T/ μ V) is determined. Using the relationship, (3), the AF(H) is determined in dB(S/m).

3 Results

3.1 The antenna factor, AF(H), results are given in Table 1.

Frequency (Hz)	Antenna factor AF(H) (dB(S/m))	AF(H) Uncertainty ($k = 1$) (\pm dB)
10	89.598	0.010
20	83.580	0.0105
50	75.613	0.0105
100	69.595	0.0105
500	55.739	0.0105
1 000	49.934	0.0105
5 000	36.701	0.0105
10 000	31.333	0.0105
50 000	24.037	0.015
100 000	23.29	0.030
120 000	23.18	0.032

Table 1. Magnetic Antenna Factor for HZ-10 loop

3.2 A graph of the antenna factor, AF(H), is shown Figure 2.

Rohde & Schwarz HZ-10, Serial No. 100149

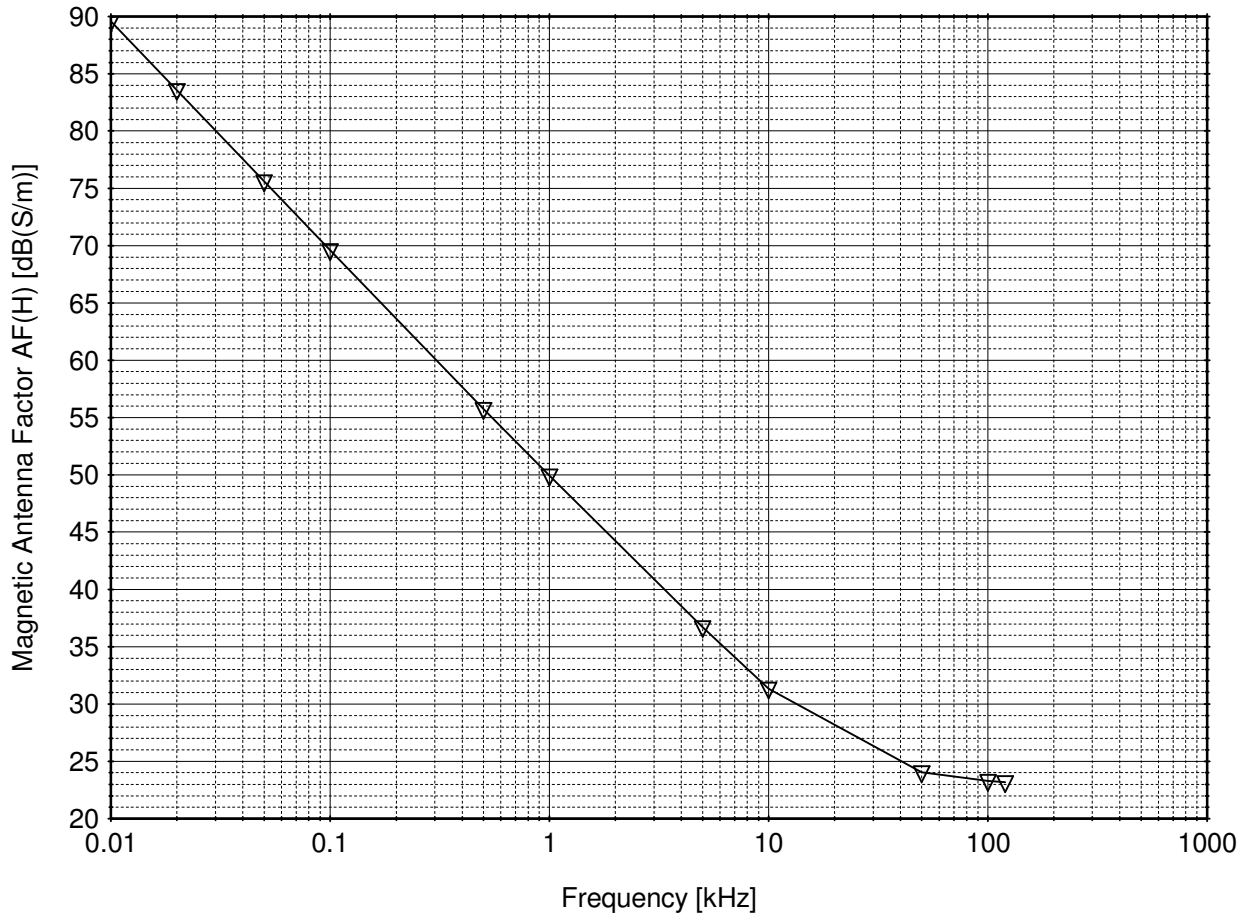

Figure 2. Magnetic Antenna Factor for HZ-10 loop

4 Detailed Uncertainty budget for Antenna Factor

4.1 Frequency: 10 Hz

Uncertainty budget at a frequency of 10 Hz							
Source of Uncertainty	Type	Value (%)	Probability distribution	Divisor	c_i	u_i (%)	v_i or v_{eff}
Calibration of Helmholtz coils	B	0.03	normal	2	1	0.0150	inf.
Helmholtz coils frequency response	B	0	normal	2	1	0.0000	inf.
DVM calibration (shunt)	B	0.05	normal	2	1	0.0250	inf.
DMM uncertainty (shunt)	B	0.024	normal	2	1	0.0120	inf.
Resolution of shunt voltage	B	0.05	rectangular	1.7321	1	0.0289	inf.
Current shunt uncertainty	B	0.02	normal	2	1	0.0100	inf.
Current shunt frequency response	B	0.03	normal	2	1	0.0150	inf.
Current shunt drift	B	0.1	rectangular	1.7321	1	0.0577	inf.
Shunt loading	B	0	rectangular	1.7321	1	0.0000	inf.
O/P resistor frequency response	B	0	rectangular	1.7321	1	0.0000	inf.
DVM calibration (loop)	B	0.05	normal	2	1	0.0250	inf.
DMM uncertainty (loop)	B	0.024	normal	2	1	0.0120	inf.
O/P voltage resolution	B	0.05	rectangular	1.7321	1	0.0289	inf.
Correction for DMM I/P impedance	B	0	rectangular	1.7321	1	0.0000	inf.
Measurement of frequency	B	0.001	rectangular	1.7321	1	0.0006	inf.
Frequency meter uncertainty	B	0.001	normal	2	1	0.0005	inf.
Loop not aligned for maximum reading	B	0.05	rectangular	1.7321	1	0.0289	inf.
Loop displaced from centre of axis	B	0.05	rectangular	1.7321	1	0.0289	inf.
Non-uniformity of field	B	0.083	rectangular	1.7321	1	0.0479	inf.
Repeatability of measurement	A	0.017	normal	1	1	0.0170	10
Combined uncertainty ($k=1$)						0.1065	15398
Combined uncertainty ($k=1$)			0.1065	%			
which equates to			0.0092	dB			
quoted uncertainty			± 0.010	dB			

4.2 Frequency: 20 Hz to 10 kHz

Uncertainty budget at frequencies of 20 Hz to 10 kHz							
Source of Uncertainty	Type	Value (%)	Probability distribution	Divisor	c_i	u_i (%)	v_i or v_{eff}
Calibration of Helmholtz coils	B	0.04	normal	2	1	0.0200	inf.
Helmholtz coils frequency response	B	0.06	normal	2	1	0.0300	inf.
DVM calibration (shunt)	B	0.05	normal	2	1	0.0250	inf.
DMM uncertainty (shunt)	B	0.024	normal	2	1	0.0120	inf.
Resolution of shunt voltage	B	0.05	rectangular	1.7321	1	0.0289	inf.
Current shunt uncertainty	B	0.05	normal	2	1	0.0250	inf.
Current shunt frequency response	B	0.03	normal	2	1	0.0150	inf.
Current shunt drift	B	0.1	rectangular	1.7321	1	0.0577	inf.
Shunt loading	B	0	rectangular	1.7321	1	0.0000	inf.
O/P resistor frequency response	B	0.01	rectangular	1.7321	1	0.0058	inf.
DVM calibration (loop)	B	0.05	normal	2	1	0.0250	inf.
DMM uncertainty (loop)	B	0.027	normal	2	1	0.0135	inf.
O/P voltage resolution	B	0.05	rectangular	1.7321	1	0.0289	inf.
Correction for DMM I/P impedance	B	0.05	rectangular	1.7321	1	0.0289	inf.
Measurement of frequency	B	0.001	rectangular	1.7321	1	0.0006	inf.
Frequency meter uncertainty	B	0.001	normal	2	1	0.0005	inf.
Loop not aligned for maximum reading	B	0.05	rectangular	1.7321	1	0.0289	inf.
Loop displaced from centre of axis	B	0.05	rectangular	1.7321	1	0.0289	inf.
Non-uniformity of field	B	0.083	rectangular	1.7321	1	0.0479	inf.
Repeatability of measurement	A	0.005	normal	1	1	0.0050	2
Combined uncertainty ($k=1$)						0.1165	590263
Combined uncertainty ($k=1$)			0.1165	%			
which equates to			0.0101	dB			
quoted uncertainty			± 0.0105	dB			

4.3 Frequency: 50 kHz

Uncertainty budget at a frequency of 50 kHz							
Source of Uncertainty	Type	Value (%)	Probability distribution	Divisor	c_i	u_i (%)	v_i or v_{eff}
Calibration of Helmholtz coils	B	0.04	normal	2	1	0.0200	inf.
Helmholtz coils frequency response	B	0.25	normal	2	1	0.1250	inf.
DVM calibration (shunt)	B	0.05	normal	2	1	0.0250	inf.
DMM uncertainty (shunt)	B	0.036	normal	2	1	0.0180	inf.
Resolution of shunt voltage	B	0.02	rectangular	1.7321	1	0.0115	inf.
Current shunt uncertainty	B	0.012	normal	2	1	0.0060	inf.
Current shunt frequency response	B	0.03	normal	2	1	0.0150	inf.
Current shunt drift	B	0.1	rectangular	1.7321	1	0.0577	inf.
Shunt loading	B	0.006	rectangular	1.7321	1	0.0035	inf.
O/P resistor frequency response	B	0.01	rectangular	1.7321	1	0.0058	inf.
DVM calibration (loop)	B	0.05	normal	2	1	0.0250	inf.
DMM uncertainty (loop)	B	0.036	normal	2	1	0.0180	inf.
O/P voltage resolution	B	0.02	rectangular	1.7321	1	0.0115	inf.
Correction for DMM I/P impedance	B	0.0675	rectangular	1.7321	1	0.0390	inf.
Measurement of frequency	B	0.001	rectangular	1.7321	1	0.0006	inf.
Frequency meter uncertainty	B	0.001	normal	2	1	0.0005	inf.
Loop not aligned for maximum reading	B	0.05	rectangular	1.7321	1	0.0289	inf.
Loop displaced from centre of axis	B	0.05	rectangular	1.7321	1	0.0289	inf.
Non-uniformity of field	B	0.083	rectangular	1.7321	1	0.0479	inf.
Repeatability of measurement	A	0.005	normal	1	1	0.0050	2
Combined uncertainty ($k=1$)						0.1653	2391339
Combined uncertainty ($k=1$)			0.1653	%			
which equates to			0.0143	dB			
quoted uncertainty			± 0.015	dB			

4.4 Frequency: 100 kHz

Uncertainty budget at a frequency of 100 kHz							
Source of Uncertainty	Type	Value (%)	Probability distribution	Divisor	c_i	u_i (%)	v_i or v_{eff}
Calibration of Helmholtz coils	B	0.04	normal	2	1	0.0200	inf.
Helmholtz coils frequency response	B	0.5	normal	2	1	0.2500	inf.
DVM calibration (shunt)	B	0.05	normal	2	1	0.0250	inf.
DMM uncertainty (shunt)	B	0.09	normal	2	1	0.0450	inf.
Resolution of shunt voltage	B	0.02	rectangular	1.7321	1	0.0115	inf.
Current shunt uncertainty	B	0.014	normal	2	1	0.0070	inf.
Current shunt frequency response	B	0.03	normal	2	1	0.0150	inf.
Current shunt drift	B	0.1	rectangular	1.7321	1	0.0577	inf.
Shunt loading	B	0.038	rectangular	1.7321	1	0.0219	inf.
O/P resistor frequency response	B	0.28	rectangular	1.7321	1	0.1617	inf.
DVM calibration (loop)	B	0.05	normal	2	1	0.0250	inf.
DMM uncertainty (loop)	B	0.09	normal	2	1	0.0450	inf.
O/P voltage resolution	B	0.02	rectangular	1.7321	1	0.0115	inf.
Correction for DMM I/P impedance	B	0.0755	rectangular	1.7321	1	0.0436	inf.
Measurement of frequency	B	0.001	rectangular	1.7321	1	0.0006	inf.
Frequency meter uncertainty	B	0.001	normal	2	1	0.0005	inf.
Loop not aligned for maximum reading	B	0.05	rectangular	1.7321	1	0.0289	inf.
Loop displaced from centre of axis	B	0.05	rectangular	1.7321	1	0.0289	inf.
Non-uniformity of field	B	0.083	rectangular	1.7321	1	0.0479	inf.
Repeatability of measurement	A	0.005	normal	1	1	0.0050	4
Combined uncertainty ($k=1$)						0.3234	7.E+07
Combined uncertainty ($k=1$)			0.3234	%			
which equates to			0.0280	dB			
quoted uncertainty			± 0.030	dB			

4.5 Frequency: 120 kHz

Uncertainty budget at a frequency of 120 kHz							
Source of Uncertainty	Type	Value (%)	Probability distribution	Divisor	c_i	u_i (%)	v_i or v_{eff}
Calibration of Helmholtz coils	B	0.04	normal	2	1	0.0200	inf.
Helmholtz coils frequency response	B	0.5	normal	2	1	0.2500	inf.
DVM calibration (shunt)	B	0.05	normal	2	1	0.0250	inf.
DMM uncertainty (shunt)	B	0.09	normal	2	1	0.0450	inf.
Resolution of shunt voltage	B	0.02	rectangular	1.7321	1	0.0115	inf.
Current shunt uncertainty	B	0.014	normal	2	1	0.0070	inf.
Current shunt frequency response	B	0.03	normal	2	1	0.0150	inf.
Current shunt drift	B	0.1	rectangular	1.7321	1	0.0577	inf.
Shunt loading	B	0.04	rectangular	1.7321	1	0.0231	inf.
O/P resistor frequency response	B	0.39	rectangular	1.7321	1	0.2252	inf.
DVM calibration (loop)	B	0.05	normal	2	1	0.0250	inf.
DMM uncertainty (loop)	B	0.09	normal	2	1	0.0450	inf.
O/P voltage resolution	B	0.02	rectangular	1.7321	1	0.0115	inf.
Correction for DMM I/P impedance	B	0.075	rectangular	1.7321	1	0.0433	inf.
Measurement of frequency	B	0.001	rectangular	1.7321	1	0.0006	inf.
Frequency meter uncertainty	B	0.001	normal	2	1	0.0005	inf.
Loop not aligned for maximum reading	B	0.05	rectangular	1.7321	1	0.0289	inf.
Loop displaced from centre of axis	B	0.05	rectangular	1.7321	1	0.0289	inf.
Non-uniformity of field	B	0.083	rectangular	1.7321	1	0.0479	inf.
Repeatability of measurement	A	0.005	normal	1	1	0.0050	2
Combined uncertainty ($k=1$)						0.3594	5.E+07
Combined uncertainty ($k=1$)			0.3594	%			
which equates to			0.0312	dB			
quoted uncertainty			± 0.032	dB			

EURAMET Supplementary Comparison: EURAMET.EM.RF-S27

Antenna factor for Loop Antennas

1 General Information

Laboratory Name	VSL
Author:	Dongsheng Zhao
Date:	3 October 2011 until 9 November 2011
Laboratory Temperature range:	$(22.9 \pm 0.5) ^\circ\text{C}$

2 Measurements procedure

2.1 Measurement method 1 (low frequency)

2.1.1 Helmholtz + Lock-in analyzer method

For generating the EM field necessary for the measurement on the loop antennas, at low frequencies (up to 100 kHz), one of the 3 coil sets of the VSL 3D Helmholtz coil was used. The EUT (equipment under test) is placed between the coil sets. A DMM (digital multi-meter) is used to measure the current flowing through the coil set using the shunt resistor.

The lock-in analyzer was used as source and detector.

In Fig.1, the Helmholtz + Lock-in analyzer method is illustrated. The measurement is done in the frequency range 10 Hz-100 kHz. The data obtained between 10 Hz and 20 kHz is used for the final result.

2.1.2 Measuring equipment

Helmholtz coils; VSL made
Justervesenet shunt JV-NT-50x50-100mA SN:010
Lock-in analyzer Stanford research systems SR 830 SN: 23354
HP 3458A SN:2823A26750
50 Ohm terminations

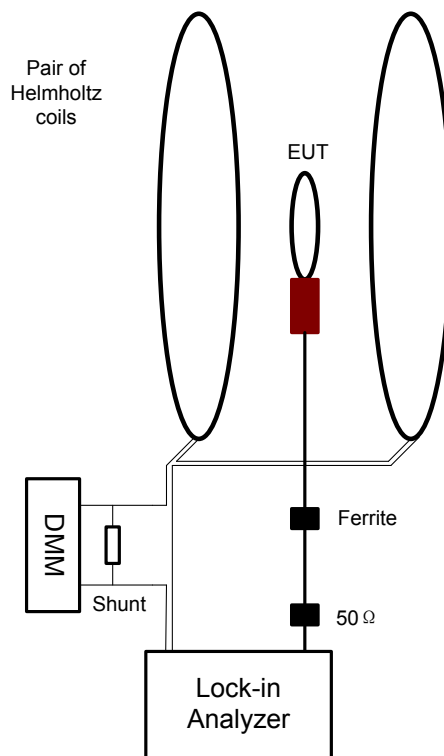

Fig. 1 Circuitry LF measurements (Helmholtz + Lock-in analyzer method)

2.2 Measurement method 2 (high frequency)

2.2.1 TEM cell + VNA (vector network analyzer) method

For the frequencies from 10 kHz and above, the 75 cm septum height symmetric TEM cell was used as the field generating device. The VNA was used as source and detector.

In Fig.2, TEM cell + VNA method is illustrated. The measurement is done in the frequency range 10 kHz-10 MHz.

2.2.2 Measuring equipment

TEM cell; VSL made
R&S VNA ZVR + Calibration kit ZV-Z21 SN:100577
50 Ohm terminations
Attenuator: KDI 30 KDIA8630N 30dB

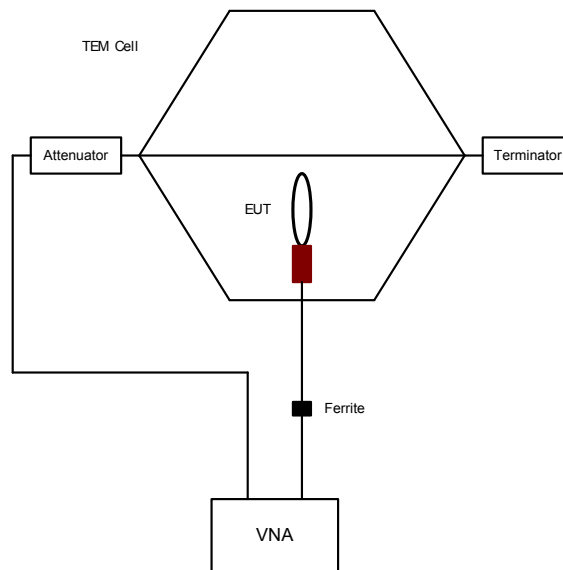

Fig. 2 Circuitry HF measurements (TEM cell + VNA method)

3 Detailed Uncertainty budget for Antenna Factor

3.1 Frequency: 10 Hz

Uncertainty budget @ the frequency of 10Hz						
Source of uncertainty	Type	Value (dB)	Probability distribution	k-factor	Sensitivity coefficient	Standard Uncertainty (dB)
Field homogeneity	B	0.020	Rectangular	1/√3	1	0.012
Angle and position of RS coil	B	0.133	Rectangular	1/√3	1	0.077
Angle and position of Reference coil	B	0.133	Rectangular	1/√3	1	0.077
Accuracy lock-in analyzer for RS coil	B	0.086	Rectangular	1/√3	1	0.050
Accuracy lock-in analyzer for Ref coil	B	0.086	Rectangular	1/√3	1	0.050
Connector, cable and repeatability	A	0.050	Gaussian	1	1	0.050
combined uncertainty (k=1)						0.14
Expanded uncertainty (k=2):						0.28

3.2 Frequency: 100 Hz

Uncertainty budget @ the frequency of 100Hz						
Source of uncertainty	Type	Value (dB)	Probability distribution	k-factor	Sensitivity coefficient	Standard Uncertainty (dB)
Field homogeneity	B	0.020	Rectangular	1/√3	1	0.012
Angle and position of RS coil	B	0.133	Rectangular	1/√3	1	0.077
Angle and position of Reference coil	B	0.133	Rectangular	1/√3	1	0.077
Accuracy lock-in analyzer for RS coil	B	0.086	Rectangular	1/√3	1	0.050

Accuracy lock-in analyzer for Ref coil	B	0.086	Rectangular	1/√3	1	0.050
Connector, cable and repeatability	A	0.050	Gaussian	1	1	0.050
combined uncertainty (k=1)						0.14
Expanded uncertainty (k=2):						0.28

3.3 Frequency: 1 kHz

Uncertainty budget @ the frequency of 1kHz						
Source of uncertainty	Type	Value (dB)	Probability distribution	k-factor	Sensitivity coefficient	Standard Uncertainty (dB)
Field homogeneity	B	0.020	Rectangular	1/√3	1	0.012
Angle and position of RS coil	B	0.133	Rectangular	1/√3	1	0.077
Angle and position of Reference coil	B	0.133	Rectangular	1/√3	1	0.077
Accuracy lock-in analyzer for RS coil	B	0.086	Rectangular	1/√3	1	0.050
Accuracy lock-in analyzer for Ref coil	B	0.086	Rectangular	1/√3	1	0.050
Connector, cable and repeatability	A	0.050	Gaussian	1	1	0.050
combined uncertainty (k=1)						0.14
Expanded uncertainty (k=2):						0.28

3.4 Frequency: 10 kHz

Uncertainty budget @ the frequency of 10kHz						
Source of uncertainty	Type	Value (dB)	Probability distribution	k-factor	Sensitivity coefficient	Standard Uncertainty (dB)
Field homogeneity	B	0.020	Rectangular	1/√3	1	0.012
Angle and position of RS coil	B	0.133	Rectangular	1/√3	1	0.077
Angle and position of Reference coil	B	0.133	Rectangular	1/√3	1	0.077
Accuracy lock-in analyzer for RS coil	B	0.086	Rectangular	1/√3	1	0.050
Accuracy lock-in analyzer for Ref coil	B	0.086	Rectangular	1/√3	1	0.050
Connector, cable and repeatability	A	0.050	Gaussian	1	1	0.050
combined uncertainty (k=1)						0.14
Expanded uncertainty (k=2):						0.28

3.5 Frequency: 100 kHz

Uncertainty budget @ the frequency of 100kHz						
Source of uncertainty	Type	Value (dB)	Probability distribution	k-factor	Sensitivity coefficient	Standard Uncertainty (dB)
Field homogeneity	B	0.053	Rectangular	1/√3	1	0.031
Angle and position of RS coil	B	0.133	Rectangular	1/√3	1	0.077

Angle and position of Reference coil	B	0.133	Rectangular	$1/\sqrt{3}$	1	0.077
S parameter measurement	B	0.150	Gaussian	1	1	0.150
Mismatch	B	0.086	Rectangular	$1/\sqrt{3}$	1	0.050
Connector, cable and repeatability	A	0.050	Gaussian	1	1	0.050
combined uncertainty (k=1)						0.20
Expanded uncertainty (k=2):						0.40

3.6 Frequency: 1 MHz

Uncertainty budget @ the frequency of 1MHz						
Source of uncertainty	Type	Value (dB)	Probability distribution	k-factor	Sensitivity coefficient	Standard Uncertainty (dB)
Field homogeneity	B	0.053	Rectangular	$1/\sqrt{3}$	1	0.031
Angle and position of RS coil	B	0.133	Rectangular	$1/\sqrt{3}$	1	0.077
Angle and position of Reference coil	B	0.133	Rectangular	$1/\sqrt{3}$	1	0.077
S parameter measurement	B	0.150	Gaussian	1	1	0.150
Mismatch	B	0.086	Rectangular	$1/\sqrt{3}$	1	0.050
Connector, cable and repeatability	A	0.050	Gaussian	1	1	0.050
combined uncertainty (k=1)						0.20
Expanded uncertainty (k=2):						0.40

3.7 Frequency: 10 MHz

Uncertainty budget @ the frequency of 10MHz						
Source of uncertainty	Type	Value (dB)	Probability distribution	k-factor	Sensitivity coefficient	Standard Uncertainty (dB)
Field homogeneity	B	0.053	Rectangular	$1/\sqrt{3}$	1	0.031
Angle and position of RS coil	B	0.133	Rectangular	$1/\sqrt{3}$	1	0.077
Angle and position of Reference coil	B	0.133	Rectangular	$1/\sqrt{3}$	1	0.077
S parameter measurement	B	0.150	Gaussian	1	1	0.150
Mismatch	B	0.086	Rectangular	$1/\sqrt{3}$	1	0.050
Connector, cable and repeatability	A	0.300	Gaussian	1	1	0.300
combined uncertainty (k=1)						0.36
Expanded uncertainty (k=2):						0.71

4 Supplementary informations

4.1 Actual measurements

The loop antenna was installed in the geometric centre of the TEM cell or the Helmholtz coils respectively using several special mounting tools. Coaxial cabling was supported by non-conducting foam material thus that the disturbance of the E-field lines was minimized (perpendicular to the field direction).

All readings were registered using the IEEE 488 interfaces of the measuring devices.

Measurements from 10 Hz up to 100 kHz at levels from 65 dB μ A/m up to 125 dB μ A/m were performed in a set of Helmholtz coils combined with a lock-in analyzer.
Measurements from 10 kHz up to 10 MHz at the level of 58 dB μ A/m up to 68 dB μ A/m were performed in a TEM cell combined with a VNA.

4.2 Repeatability

All measurements were repeated at least two times. Also the loop was exposed after turning it 180 degrees around its axis.

The reproducibility has been tested by removing and reinstalling the probe.

The results appeared to be completely in line with each other considering the uncertainty in the measurements.

4.3 Traceability

The properties of the Helmholtz set up are based on DC properties as well as theoretical properties on basis of the geometrical dimensions.

The DC measurements were performed using a DC current source and a calibrated Hall probe.

The Hall probe calibration is performed in an NMR magnetometer facility.

A home-made single turn coil is used to measure the discrepancy between the AC properties and DC properties of the Helmholtz coil. Since the resonance frequency of this single turn coil is far above the maximum frequency of interest, the AC properties of the single turn coil have been considered to be calculable.

4.4 Equipments used for impedance measurement

Measurement method used: LCR meter (10 Hz - 2 MHz)

System components

QuadTech Precision LCR meter 10Hz – 2MHz SN:5460026

Measurement method used: VNA (10 kHz - 10 MHz)

System components

Rohde und Schwarz VNA ZVR + Calibration kit ZV-Z21 SN:100577
--

4.5 Measurement results

EURAMET Supplementary Comparison: EURAMET.EM.RF-S27 Antenna factor for Loop Antennas

Laboratory Name	VSL
Author	Dongsheng Zhao
Date	3 October 2011 until 9 November 2011
Laboratory Temperature range	(22.9 ± 0.5)°C
Calibration methods	Helmholtz + Lock-in analyzer method TEM cell + Lock-in analyzer method TEM cell + VNA method
Measuring equipment	Helmholtz coils; VSL made Justervesenet shunt JV-NT-50x50-100mA SN:010 Lock-in analyzer Standord research systems SR 830 SN: 23354 HP 3458A SN:2823A26750 50 Ohm terminations TEM cell; VSL made Attenuator: KDI 30 KDIA8630N 30dB Rohde und Schwarz VNA ZVR + Calibration kit ZV-Z21 SN:100577 QuadTech Precison LCR meter 10Hz – 2MHz SN:5460026

Frequency (Hz)	Free Field antenna factor (dB(S/m))	Total Standard Uncertainty on AF (k=1) (dB)	S11 parameter (Real Part) ()	S11 parameter (Imaginary Part) ()	Total Standard Uncertainty on Re[S11] (k=1) ()	Total Standard Uncertainty on Im[S11] (k=1) ()
10	89.57	0.14	-0.655	0.00085	0.003	0.00002
20	83.55	0.14	-0.655	0.00169	0.003	0.00002
30	80.03	0.14	-0.656	0.00251	0.003	0.00004
40	77.53	0.14	-0.656	0.00334	0.003	0.00005
50	75.60	0.14	-0.656	0.0041	0.003	0.0001
60	74.01	0.14	-0.655	0.0050	0.003	0.0001
70	72.67	0.14	-0.655	0.0058	0.003	0.0001
80	71.51	0.14	-0.655	0.0067	0.003	0.0001
90	70.49	0.14	-0.655	0.0075	0.003	0.0001
100	69.57	0.14	-0.655	0.0083	0.003	0.0001
200	63.55	0.14	-0.655	0.0166	0.003	0.0002
300	60.05	0.14	-0.655	0.0249	0.003	0.0003
400	57.58	0.14	-0.654	0.0331	0.003	0.0004
500	55.69	0.14	-0.653	0.041	0.003	0.001
600	54.15	0.14	-0.652	0.049	0.003	0.001
700	52.85	0.14	-0.651	0.057	0.003	0.001
800	51.74	0.14	-0.650	0.065	0.003	0.001
900	50.76	0.14	-0.649	0.073	0.003	0.001
1000	49.89	0.14	-0.648	0.081	0.003	0.001
2000	44.17	0.14	-0.632	0.155	0.003	0.002
3000	40.83	0.14	-0.611	0.225	0.003	0.003
4000	38.47	0.14	-0.586	0.291	0.004	0.004
5000	36.65	0.14	-0.556	0.353	0.004	0.004
6000	35.19	0.14	-0.522	0.411	0.004	0.005
7000	33.98	0.14	-0.485	0.464	0.005	0.005
8000	32.95	0.14	-0.445	0.513	0.005	0.006

9000	32.07	0.14	-0.403	0.558	0.006	0.006
10000	31.30	0.14	-0.359	0.598	0.006	0.006
20000	27.00	0.14	0.073	0.789	0.008	0.003
30000	25.23	0.20	0.384	0.770	0.008	0.003
40000	24.37	0.20	0.577	0.695	0.007	0.004
50000	23.92	0.20	0.697	0.614	0.005	0.004
60000	23.66	0.20	0.773	0.544	0.004	0.004
70000	23.45	0.20	0.826	0.484	0.003	0.004
80000	23.33	0.20	0.862	0.434	0.005	0.005
90000	23.25	0.20	0.888	0.392	0.005	0.005
100000	23.18	0.20	0.908	0.357	0.005	0.005
200000	22.94	0.20	0.975	0.179	0.005	0.005
300000	22.89	0.20	0.988	0.112	0.005	0.005
400000	22.85	0.20	0.993	0.074	0.005	0.005
500000	22.83	0.20	0.995	0.050	0.005	0.005
600000	22.83	0.20	0.997	0.031	0.005	0.005
700000	22.84	0.20	0.997	0.016	0.005	0.005
800000	22.82	0.20	0.997	0.004	0.005	0.005
900000	22.84	0.20	0.997	-0.007	0.005	0.005
1000000	22.85	0.20	0.997	-0.017	0.005	0.005
2000000	22.84	0.20	0.993	-0.093	0.005	0.005
3000000	22.96	0.20	0.985	-0.155	0.005	0.005
4000000	23.10	0.20	0.972	-0.217	0.005	0.005
5000000	23.36	0.20	0.954	-0.278	0.005	0.005
6000000	23.66	0.20	0.928	-0.340	0.005	0.005
7000000	24.67	0.20	0.893	-0.398	0.005	0.006
8000000	25.63	0.24	0.848	-0.462	0.005	0.006
9000000	26.05	0.38	0.761	-0.507	0.005	0.006
10000000	24.40	0.36	0.746	-0.473	0.005	0.006

EURAMET Supplementary Comparison: EURAMET.EM.RF-S27

Antenna factor for Loop Antennas

Report of the measurements performed at INRIM (Torino, Italy)

1 General Information

Laboratory Name	INRIM
Authors:	M. Borsero, D. Giordano, G. Vizio
Date:	from 2012-01-16 to 2012-02-02
Laboratory Temperature range:	(23±1) °C

2 Measurements procedure

Two different calibration methods were used: one for the lower frequency range (10 Hz to 100 kHz) and one for the higher frequency range (200 kHz to 10 MHz).

2.1 Measurement method 1 (lower frequency)

2.1.1 Method

From 10 Hz to 100 kHz the loop antenna was calibrated by the INRIM Helmholtz coil system for the generation of reference magnetic fields. A 50 Ω load was connected through a T adapter to the coaxial cable supplied with the loop antenna. The antenna factor was obtained by measuring the voltage across the loop antenna load with a lock-in amplifier previously calibrated, while the generated magnetic field strength was estimated by the product of the system coil constant (generated magnetic field/per unit current) and the current flowing in the coils, measured through a non-inductive shunt and a voltmeter.

The DC coil constant of the Helmholtz coil system was determined by means of a Hall effect meter, traceable to the national reference for DC magnetic field. Correction factors were introduced to take into account stray parameter effects as a function of the frequency.

The models for the measurement of the output voltage and the generated magnetic field are given by:

$$U = k_{LI} \cdot V_{LI} \cdot \frac{50}{R_{50meas}} \quad (1)$$

$$H = \frac{k_0}{R_{guild}} \cdot V_{mult} \cdot d_{tot} \quad \text{for frequencies } \leq 30 \text{ kHz} \quad (2a)$$

$$H = \frac{k_0 \cdot h_{tot}}{R_{guild}} \cdot V_{mult} \cdot d_{tot} \quad \text{for frequencies } > 30 \text{ kHz} \quad (2b)$$

where:

- U is the output voltage across the 50 Ω load;
- V_{LI} is the lock-in amplifier output;
- $R_{50 \text{ meas}}$ is the measurement value of the 50 Ω load;
- k_{LI} is the lock-in amplifier calibration factor;
- H is the generated magnetic field strength;
- k_0 is the Helmholtz system DC coil constant;
- h_{tot} is the correction factor that takes into account the stray capacitances introduced by the connection cable between the shunt and the coils and those between the turns;
- d_{tot} takes into account the non-uniformity of the generated magnetic field and the perturbation introduced by the floor and walls;
- V_{mult} is the voltage across the shunt;
- R_{guild} is the non-inductive shunt resistance value.

The loop antenna factor is then obtained as:

$$AF = 20 \cdot \log \frac{H}{U} \quad (3)$$

2.1.2 Measuring equipment

Lock-in amplifier	NF Corporation	mod. LI5640
Helmholtz coil system	INRIM (17 turns per coil; 0,35 m radius)	
AC Shunt 0,1 Ω , 10 W	Guildline	mod. 7320
Multimeter	Agilent Technologies	mod. 3458
Impedance analyzer	Agilent Technologies	mod. 4294A

2.2 Measurement method 2 (higher frequency)

2.2.1 Method

From 200 kHz to 10 MHz the loop antenna was calibrated by means of the so called "Standard-Field Method". The reference magnetic field was generated using a standard transmitting loop antenna, which is a single turn shielded loop with a 0,25 m diameter. The current feeding the loop was measured through a radio-frequency current probe and a power meter.

The travelling standard was placed in the reference field, aligned coaxially with the transmitting antenna at distances ranging from 0,4 m to 1 m.

The average magnetic field strength was calculated from the diameters of the transmitting loop and travelling standard, the distance between them and the current feeding the transmitting loop.

The antenna factor was obtained from the ratio of the average magnetic field to the voltage measured on a 50 Ω load by means of a spectrum analyzer.

2.2.2 Measuring equipment

Signal generator	Rohde & Schwarz	mod. SML03
Transmitting loop	INRIM (single turn; 0,25 m diameter)	
Power meter	Agilent Technologies	mod. N1914A
Power sensor	Agilent Technologies	mod. 8482A
Current Probe	Rohde & Schwarz	mod. ESH2-Z1
Spectrum analyzer	Rohde & Schwarz	mod. FSP13
Vector Network Analyzer	Rohde & Schwarz	mod. ZVRE

3 Detailed Uncertainty budget for Antenna Factor

3.1 Frequency: 10 Hz

Uncertainty budget @ the frequency of 10 Hz						
Source of uncertainty	Type	Value (dB)	Probability distribution	k-factor	Sensitivity coefficient	Standard uncertainty (dB)
DC coil constant k_0	B	0,019	Normal	2,00	1	0,0095
Shunt resistance R_{quild}	B	0,004	Rectangular	1,73	1	0,0025
Voltage across the shunt V_{mult}	B	0,008	Rectangular	1,73	1	0,0043
Field non-uniformity and floor effects d_{tot}	B	0,031	Rectangular	1,73	1	0,018
Lock-in amplifier calibration factor k_{LI}	B	0,030	Rectangular	1,73	1	0,017
50 Ω load $R_{50 \text{ meas}}$	B	0,001	Rectangular	1,73	1	0,0004
Output voltage across the 50 Ω load V_{LI}	B	0,031	Rectangular	1,73	1	0,018
Repeatability	A	0,010	Normal	1,00	1	0,010
Total Uncertainty (k=1)						0,034

3.2 Frequency: 100 Hz

Uncertainty budget @ the frequency of 100 Hz						
Source of uncertainty	Type	Value (dB)	Probability distribution	k-factor	Sensitivity coefficient	Standard uncertainty (dB)
DC coil constant k_0	B	0,019	Normal	2,00	1	0,0095
Shunt resistance R_{quild}	B	0,004	Rectangular	1,73	1	0,0025
Voltage across the shunt V_{mult}	B	0,008	Rectangular	1,73	1	0,0043
Field non-uniformity and floor effects d_{tot}	B	0,031	Rectangular	1,73	1	0,018
Lock-in amplifier calibration factor k_{LI}	B	0,030	Rectangular	1,73	1	0,017
50 Ω load $R_{50 \text{ meas}}$	B	0,001	Rectangular	1,73	1	0,0004
Output voltage across the 50 Ω load V_{LI}	B	0,010	Rectangular	1,73	1	0,006
Repeatability	A	0,010	Normal	1,00	1	0,010
Total Uncertainty (k=1)						0,030

3.3 Frequency: 1 kHz

Uncertainty budget @ the frequency of 1 kHz						
Source of uncertainty	Type	Value (dB)	Probability distribution	k-factor	Sensitivity coefficient	Standard uncertainty (dB)
DC coil constant k_0	B	0,019	Normal	2,00	1	0,0095
Shunt resistance R_{quild}	B	0,004	Rectangular	1,73	1	0,0025
Voltage across the shunt V_{mult}	B	0,008	Rectangular	1,73	1	0,0043
Field non-uniformity and floor effects d_{tot}	B	0,031	Rectangular	1,73	1	0,018
Lock-in amplifier calibration factor k_{LI}	B	0,030	Rectangular	1,73	1	0,017
50 Ω load $R_{50 \text{ meas}}$	B	0,001	Rectangular	1,73	1	0,0004
Output voltage across the 50 Ω load V_{LI}	B	0,009	Rectangular	1,73	1	0,005
Repeatability	A	0,010	Normal	1,00	1	0,010
Total Uncertainty (k=1)						0,029

3.4 Frequency: 10 kHz

Uncertainty budget @ the frequency of 10 kHz						
Source of uncertainty	Type	Value (dB)	Probability distribution	k-factor	Sensitivity coefficient	Standard uncertainty (dB)
DC coil constant k_0	B	0,019	Normal	2,00	1	0,0095
Shunt resistance R_{quild}	B	0,004	Rectangular	1,73	1	0,0025
Voltage across the shunt V_{mult}	B	0,008	Rectangular	1,73	1	0,0043
Field non-uniformity and floor effects d_{tot}	B	0,031	Rectangular	1,73	1	0,018
Lock-in amplifier calibration factor k_{LI}	B	0,030	Rectangular	1,73	1	0,017
50 Ω load $R_{50 \text{ meas}}$	B	0,001	Rectangular	1,73	1	0,0004
Output voltage across the 50 Ω load V_{LI}	B	0,009	Rectangular	1,73	1	0,005
Repeatability	A	0,010	Normal	1,00	1	0,010
Total Uncertainty (k=1)						0,029

3.5 Frequency: 100 kHz

Uncertainty budget @ the frequency of 100 kHz						
Source of uncertainty	Type	Value (dB)	Probability distribution	k-factor	Sensitivity coefficient	Standard uncertainty (dB)
DC coil constant k_0	B	0,021	Normal	2,00	1	0,010
Stray parameter correction factor h_{tot}	B	0,018	Rectangular	1,73	1	0,01
Shunt resistance R_{quild}	B	0,004	Rectangular	1,73	1	0,0025
Voltage across the shunt V_{mult}	B	0,012	Rectangular	1,73	1	0,007
Field non-uniformity and floor effects d_{tot}	B	0,035	Rectangular	1,73	1	0,02
Lock-in amplifier calibration factor k_{LI}	B	0,030	Rectangular	1,73	1	0,017
50 Ω load $R_{50 \text{ meas}}$	B	0,001	Rectangular	1,73	1	0,0004
Output voltage across the 50 Ω load V_{LI}	B	0,009	Rectangular	1,73	1	0,005
Repeatability	A	0,010	Normal	1,00	1	0,010
Total Uncertainty (k=1)						0,033

3.6 Frequency: 1 MHz

Uncertainty budget @ the frequency of 1 MHz						
Source of uncertainty	Type	Value (dB)	Probability distribution	k-factor	Sensitivity coefficient	Standard uncertainty (dB)
Transmitting antenna feed current	B	0,83	Normal	2,00	1	0,42
Receiving loop output voltage	B	0,41	Normal	2,00	1	0,20
Separation distance and loop alignment	B	0,10	Rectangular	1,73	1	0,06
Field non-uniformity	B	0,27	Rectangular	1,73	1	0,16
Repeatability	A	0,24	Normal	1,00	1	0,24
Total Uncertainty (k=1)						0,55

3.7 Frequency: 10 MHz

Uncertainty budget @ the frequency of 10 MHz						
Source of uncertainty	Type	Value (dB)	Probability distribution	k-factor	Sensitivity coefficient	Standard uncertainty (dB)
Transmitting antenna feed current	B	0,82	Normal	2,00	1	0,41
Receiving loop output voltage	B	0,40	Normal	2,00	1	0,20
Separation distance and loop alignment	B	0,10	Rectangular	1,73	1	0,06
Field non-uniformity	B	0,34	Rectangular	1,73	1	0,20
Repeatability	A	0,25	Normal	1,00	1	0,25
Total Uncertainty (k=1)						0,56

EURAMET Supplementary Comparison: EURAMET.EM.RF-S27

Antenna factor for Loop Antennas

1 General Information

Laboratory Name	Laboratoire national de métrologie et d'essais
Author:	Yannick LE SAGE
Date:	21/02/2012 – 22/02/2012
Laboratory Temperature range:	23,0±1,5 °C

2 Measurements procedure

2.1 Measurement method 1 (low frequency)

2.1.1 Method

/

2.1.2 Measuring equipment

/

2.2 Measurement method 2 (high frequency)

2.2.1 Method

Method by substitution

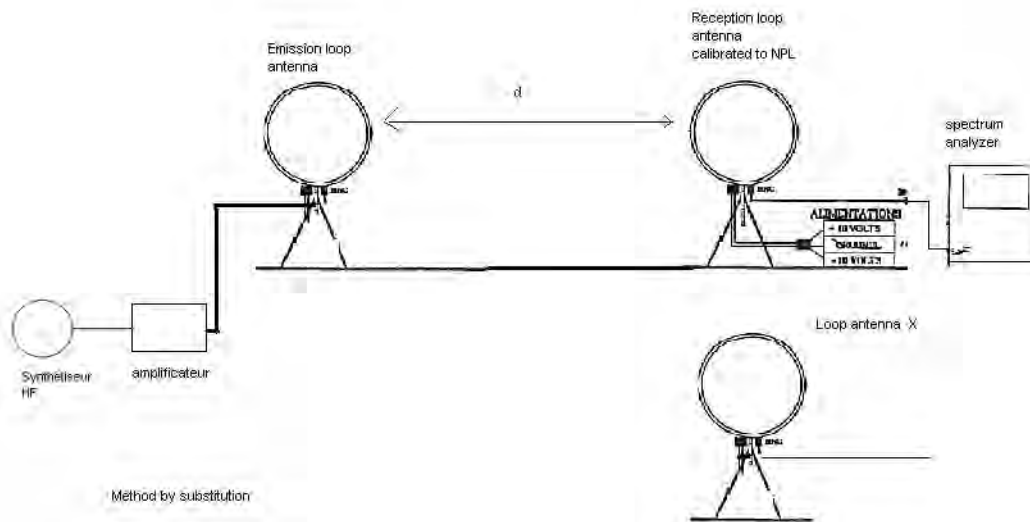

$$E = F + P + U$$

With :

E : Electric field (dB μ V/m)

F : antenna Factor (dB/m)

P : Cable Insertion loss (dB)

U : Voltage measured on spectrum analyzer (dB μ V)

As the uncertainties in dB are small, mathematic model is :

$$(u(E))^2 = (u(F))^2 + (u(P))^2 + (u(U))^2$$

2.2.2 Measuring equipment

Equipment used :

- spectrum analyzer Rohde & Schwarz FSEK 30 N°841 829/003
- synthesizer HP3325B
- loop antenna Rohde & Schwarz HF H2-Z2 N°841 801/007
- amplifier PRANA AP32DT20

3 Detailed Uncertainty budget for Antenna Factor

3.1 Frequency: 10 Hz

/

3.2 Frequency: 10 kHz

Uncertainty budget @ the frequency of 10 kHz						
Source of uncertainty	Type	Value	Probability distribution	k-factor	Sensitivity coefficient	Standard Uncertainty (dB)
Repeatability/alignment	A	0,16	k=1	1	1	0.16
loop antenna calibration	B	1,00	k=2	2	1	0.50
Spectrum analyzer calibration	B	0,40	k=2	2	1	0.20
attenuation cable calibration	B	0,04	k=1	1	1	0.04
drift loop antenna	B	0,70	Rectangular	3,46	1	0.20
drift spectrum analyzer	B	0,35	Rectangular	3,46	1	0.10
resolution spectrum analyzer	B	0,005	Rectangular	1,73	1	0.00
temperature variation on spectrum analyzer	B	0,10	Rectangular	1,73	1	0.06
Total Uncertainty (k=1)						0.61

3.3 Frequency: 100 kHz

Uncertainty budget @ the frequency of 100 kHz						
Source of uncertainty	Type	Value	Probability distribution	k-factor	Sensitivity coefficient	Standard Uncertainty (dB)
repeatability	A	0,17	k=1	1	1	0.17
loop antenna calibration	B	1,00	k=2	2	1	0.50
Spectrum analyzer calibration	B	0,40	k=2	2	1	0.20
attenuation cable calibration	B	0,04	k=1	1	1	0.04
drift loop antenna	B	0,70	Rectangular	3,46	1	0.20
drift spectrum analyzer	B	0,35	Rectangular	3,46	1	0.10
resolution spectrum analyzer	B	0,005	Rectangular	1,73	1	0.00
temperature variation on spectrum analyzer	B	0,10	Rectangular	1,73	1	0.06
Total Uncertainty (k=1)						0.61

3.4 Frequency: 1 MHz

Uncertainty budget @ the frequency of 1 MHz						
Source of uncertainty	Type	Value	Probability distribution	k-factor	Sensitivity coefficient	Standard Uncertainty (dB)
repeatability	A	0,16	k=1	1	1	0.16
loop antenna calibration	B	1,00	k=2	2	1	0.50
Spectrum analyzer calibration	B	0,40	k=2	2	1	0.20
attenuation cable calibration	B	0,04	k=1	1	1	0.04
drift loop antenna	B	0,70	Rectangular	3,46	1	0.20
drift spectrum analyzer	B	0,35	Rectangular	3,46	1	0.10
resolution spectrum analyzer	B	0,005	Rectangular	1,73	1	0.00
temperature variation on spectrum analyzer	B	0,10	Rectangular	1,73	1	0.06
Total Uncertainty (k=1)						0.61

3.5 Frequency: 10 MHz

Uncertainty budget @ the frequency of 10 MHz						
Source of uncertainty	Type	Value (dB)	Probability distribution	k-factor	Sensitivity coefficient	Standard Uncertainty (dB)
repeatability	A	0,14	k=1	1	1	0,14
loop antenna calibration	B	1,00	k=2	2	1	0,50
Spectrum analyzer calibration	B	0,40	k=2	2	1	0,20
attenuation cable calibration	B	0,04	k=1	1	1	0,04
drift loop antenna	B	0,70	Rectangular	3,46	1	0,20
drift spectrum analyzer	B	0,35	Rectangular	3,46	1	0,10
resolution spectrum analyzer	B	0,005	Rectangular	1,73	1	0,00
temperature variation on spectrum analyzer	B	0,10	Rectangular	1,73	1	0,06
Total Uncertainty (k=1)						0,60

Annex to LNE results

After completion of the comparison, LNE noticed that some of their results were outside of their uncertainty declaration. Therefore a new correction was developed by LNE to overcome this problem.

The algorithm is explained here below, but the LNE results documented in the main part of the comparison have not been corrected by this algorithm.

Algorithm

An algorithm is developed and coded in Excel to allow simple use.

The calculation a positioning of the antennas according to fig 1 with the following parameters :

- Radius of transmit antenna
- Radius of standard receive antenna
- Radius of calibrated receive antenna
- Distance between antennas
- Frequency

fig : 1 : substitution method

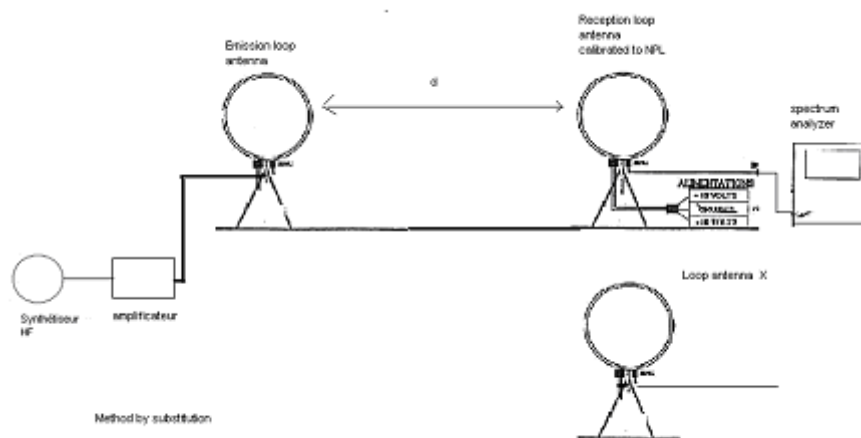

The current flowing along the wire of the loop is supposed to be uniform, because of the small size of transmitting antenna to the wavelength. $\lambda=30$ m (for $f=10$ MHz)

This current is decomposed into unitary elements. The H-Field radiated at the location of antenna under test is then calculated for each of this current elements, the contributions of each currents are summed, taking into account the phase information..

The flow of the fields through an antenna loop is computed only for the vector component of the field perpendicular to the plane of the receive antenna.

The plane of receive antenna is parallel to the plane of the transmitting antenna.

Formulas for the current radiated by an elementary current are derived from the Book : Principles of planar near-field antenna measurements (S. Gregson, J. McCormick, C. Parini)

Below the component H_y of the field radiated by an elementary current is given for a current aligned with axis Z.

Component H_y on axis Z

$$\Re(H_y) = -\frac{I_0 \cdot dl}{2\lambda \cdot R} \left(\left(\frac{\lambda}{2\pi \cdot R} \right) \cos(kR) + \sin(kR) \right) \left(\frac{x}{R} \right)$$

Component H_y on axis X

$$\Re(H_y) = -\frac{I_0 \cdot dl}{2\lambda \cdot R} \left(\left(\frac{\lambda}{2\pi \cdot R} \right) \cos(kR) + \sin(kR) \right) \left(\frac{z}{R} \right)$$

This calculation is implemented in a spreadsheet with a line for each point for different locations. The calculation includes the two perpendicular components of current and the contribution are summed for each elementary current along the wire of the loop. The H field calculated by this method is given on figure 2, for a line parallel to the plane of the receiving loop.

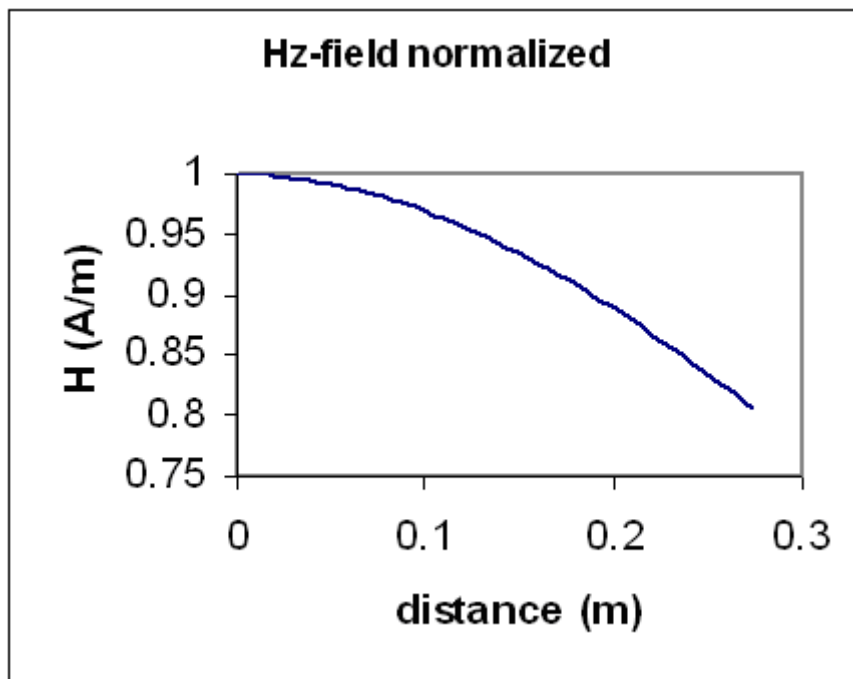

Fig 2 : Representation of Hz field according to the distance

The correction factor is determined by the summation of the H field along this line from 0m to the radius of the receiving antenna, either the standard or the calibrated antenna.

For a calibrated antenna smaller than the the receiving standard, H fields flow normalized by the antenna surface in calibrated antenna is higher than for the standard antenna, leading to an underestimate of the calibrated antenna factor. The correction factor is calculated as the ratio of the H fields flow normalized by the antenna surface in the calibrated antenna over the same ratio for the standard antenna.

In the case of the comparison the ration is positive. We must add the correction factor calculated below (cf fig 2 and 3) in order to compensate the effective antenna factor for the H field non-uniformity.

Case : receiving antenna with radius=0,055cm (fig 3)

Correction of Antenna factor according to the frequency :

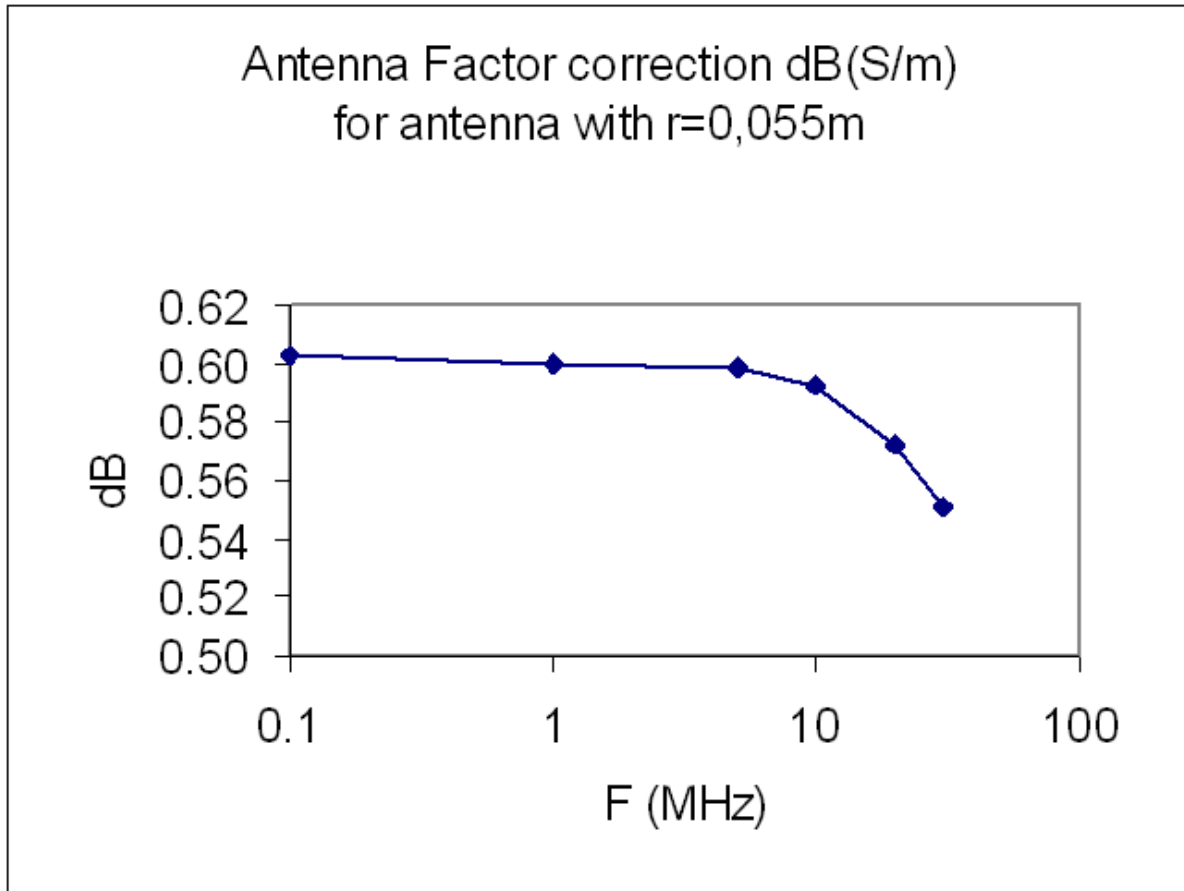

figure : 3 antenna factor correction

The average correction factor is +0.59 dB and decreases to +0.54 dB when the frequency reaches 30 MHz.

Figure 4 : a chart with different corrections according to the radius :

frequency	loop antenna			
	r=0,055 m	r=0,155m	r=0,275m	r=0,55m
MHz	antenna factor correction (dB)	antenna factor correction (dB)	antenna factor correction (dB)	antenna factor correction (dB)
0.009	+0.59	+0.40	0.00	-1.55
0.1	+0.59	+0.40	0.00	-1.55
1	+0.59	+0.40	0.00	-1.55
10	+0.58	+0.40	0.00	-1.53
30	+0.54	+0.37	0.00	-1.41

Antenna factor for comparison :

frequency (Hz)	antenna factor dB(S/m) EURAMET EM RF-S27	antenna factor corrector	new value : antenna factor corrected dB(S/m)	uncertainty on antenna factor (dB)
9000	30.7	+0.6	31.3	0.61
10000	29.9	+0.6	30.5	0.61
20000	25.6	+0.6	26.2	0.61
30000	23.8	+0.6	24.4	0.61
40000	23.0	+0.6	23.6	0.61
50000	22.5	+0.6	23.1	0.61
60000	22.2	+0.6	22.8	0.61
70000	22.1	+0.6	22.7	0.61
80000	22.0	+0.6	22.5	0.61
90000	21.8	+0.6	22.4	0.61
100000	21.7	+0.6	22.3	0.61
200000	21.5	+0.6	22.1	0.61
300000	21.4	+0.6	22.0	0.61
400000	21.4	+0.6	22.0	0.61
500000	21.4	+0.6	22.0	0.61
600000	21.4	+0.6	21.9	0.61
700000	21.4	+0.6	21.9	0.61
800000	21.4	+0.6	21.9	0.61
900000	21.4	+0.6	21.9	0.61
1000000	21.4	+0.6	21.9	0.61
2000000	21.5	+0.6	22.1	0.61
3000000	21.6	+0.6	22.2	0.61
4000000	21.8	+0.6	22.4	0.61
5000000	22.3	+0.6	22.9	0.61
6000000	22.9	+0.6	23.5	0.61
7000000	23.8	+0.6	24.4	0.61
8000000	24.9	+0.6	25.5	0.61
9000000	25.4	+0.6	25.9	0.61
10000000	23.8	+0.6	24.4	0.60

EURAMET Supplementary Comparison: EURAMET.EM.RF-S27

Antenna factor for Loop Antennas

1 General Information

Laboratory Name	Czech Metrology Institute, Microwave Measurement Laboratory
Author:	Karel Dražil
Date:	9. 3. – 30. 3. 2012
Laboratory Temperature range:	(21.5 – 23.0)°C

2 Measurements procedure

2.1 Measurement method 1

2.1.1 Method

Measurement in Helmholtz coils

The loop antenna was calibrated in Helmholtz coils (2 x 1 turn, 0.4 m diameter). At frequencies up to 5 kHz a multifunction calibrator with transconductance amplifier was used as the current generating device. At higher frequencies an arbitrary waveform generator was used as signal source and the current delivered to the coils was measured by means of coaxial shunt resistor and AC voltmeter (up to 100 kHz) or RF power meter, respectively. The voltage delivered by the antenna under test to the 50 Ω load was measured using the AC voltmeter (up to 100 kHz) or RF power meter, respectively. Antenna factor AF was calculated using formula

$$AF = 20 \log \left(\frac{K_H I}{U} \right),$$

where K_H is the H-constant of Helmholtz coils, I is the current in the coils and U is the voltage at the antenna output terminated in 50 Ω load.

The complex reflection coefficient of the antenna at frequencies up to 100 kHz was calculated from impedance values measured using an LCR meter. A vector network analyzer (calibrated using OSL technique) was used to obtain reflection coefficient values in frequency band from 100 kHz to 10 MHz.

2.1.2 Measuring equipment

Helmholtz coil 2 x 1 turn, 0.4 m diameter, self made, calibration constant $K_B = 4.462 \mu\text{T/A}$
Multifunction calibrator, model 4800, Wavetek, ser. no. 29960
Transconductance amplifier, model 4600, Wavetek – Datron, ser. no. 27131
Arbitrary waveform generator, model 33120A, Hewlett – Packard, ser. no. US34020521
Audioanalyzer, model 8903A, Hewlett – Packard, ser. no. 2505A05285
50 Ω termination, model II-0049, Tektronix
Coaxial shunt resistor 10 m Ω , model CSR2, RAO, ser. no. 005
Power sensor, model NRV-Z4, Rohde & Schwarz, ser. no. 848264/008
Power sensor, model NRV-Z5, Rohde & Schwarz, ser. no. 100410
RF power meter, model NRVD, Rohde & Schwarz, ser. no. 835843/022
RF power meter, model NRVS, Rohde & Schwarz, ser. no. 100125
Multi-frequency LCR meter, model 4274A, Hewlett – Packard, ser. no. 2147J02200
Vector analyzer, model BM553, Tesla, ser. no. 019365
Steel ruler 500 mm, Preisser, GmbH., no. 67

2.2 Measurement method 2 (high frequency)

2.2.1 Method

Measurement with reference transmitting loop antenna

In the frequency range from 100 kHz to 10 MHz a small single-turn unbalanced loop antenna (with calculable antenna factor) was used to generate the standard magnetic field. The transmitting and receiving loop antennas were positioned coaxially to each other at a spacing of 27 cm. A measuring receiver was used to measure the incident power delivered to the transmitting antenna and the power delivered by the receiving antenna, respectively. In order to eliminate linearity error of the receiver, reference attenuator with attenuation value near to that of the measurement setup was used during the measurement of the power delivered to the transmitting antenna. Antenna factor AF_2 of the receiving antenna was obtained using formula

$$AF_2 = 10 \log \frac{P_1}{P_2} - AF_1 + 20 \log \frac{\sqrt{1 + \left(\frac{2\pi Df}{c}\right)^2}}{240R_0\pi^3 \frac{f}{c} (D^2 + r_1^2 + r_2^2)^{\frac{3}{2}}},$$

where AF_1 is the (magnetic) antenna factor of the transmitting loop antenna, P_1 is the incident power at the transmitting antenna, P_2 is the power delivered by receiving antenna to the load $R_0 = 50 \Omega$, D is spacing between antennas, r_1 , r_2 are radii of transmitting and receiving loops, respectively, f is the frequency and c is the light velocity.

Reflection coefficient of the antenna was measured using vector network analyzer (OSL calibrated).

2.2.2 Measuring equipment

Single-turn loop antenna, diameter 0.1 m, self made, no. 01

Measuring receiver, model ESCS30, Rohde & Schwarz, ser. no. 847793/019

Arbitrary waveform generator, model 33120A, Hewlett – Packard, ser. no. US34020521

Attenuator 40 dB, Weinschel, ser. no. BB8367

Attenuator 30 dB, Weinschel, ser. no. BB8427

Attenuator 10 dB, Weinschel, ser. no. BB8878

Steel ruler 500 mm, Preisser, GmbH., no. 67

Vector analyzer, model BM553, Tesla, ser. no. 019365

2.3 Measurement method 3 (high frequency)

2.3.1 Method

Measurement in TEM cell

In the frequency range from 100 kHz to 10 MHz, an alternative measurement in TEM cell (with nominal characteristic impedance 50Ω) was performed. The loop antenna was placed in the center of the cell, halfway between the bottom wall and the septum. RF power meters with 50Ω sensors were used to measure the power at the output of the TEM cell and at the antenna output. Antenna factor AF was calculated using formula

$$AF = 10 \log \left(\frac{P_T}{P_u} \right) - 20 \log(120\pi h),$$

where P_T is the power measured at the output of the TEM cell, P_u is the power measured at the antenna output and h is the distance between septum and bottom wall of the cell.

Reflection coefficient of the antenna was measured using vector network analyzer (OSL calibrated).

2.3.2 Measuring equipment

Rectangular TEM cell, septum to wall distance 0.25 m, own design

Arbitrary waveform generator, model 33120A, Hewlett – Packard, ser. no. US34020521

Power sensor, model NRV-Z4, Rohde & Schwarz, ser. no. 848264/008

Power sensor, model NRV-Z5, Rohde & Schwarz, ser. no. 100410

RF power meter, model NRVD, Rohde & Schwarz, ser. no. 835843/022

RF power meter, model NRVS, Rohde & Schwarz, ser. no. 100125

3 Detailed Uncertainty budget for Antenna Factor

3.1 Frequency: 10 Hz (measurement in Helmholtz Coils)

Uncertainty budget @ the frequency of 10 Hz						
Source of uncertainty	Type	Value (dB)	Probability distribution	k-factor	Sensitivity coefficient	Standard Uncertainty (dB)
Helmholtz coil calibration constant uncertainty	B	0.0217	normal	1	1	0.0217
Current uncertainty	B	0.0087	normal	1	1	0.0087
Imperfect antenna termination influence	B	0.0008	normal	1	1	0.0008
Voltage meas. uncertainty	B	0.0130	normal	1	1	0.0130
Field Homogeneity	B	0.0647	normal	1	1	0.0647
Repeatability	A	0.0014	normal	1	1	0.0014
Total Uncertainty (k=1)						0.070

3.2 Frequency: 100 Hz (measurement in Helmholtz Coils)

Uncertainty budget @ the frequency of 100 Hz						
Source of uncertainty	Type	Value (dB)	Probability distribution	k-factor	Sensitivity coefficient	Standard Uncertainty (dB)
Helmholtz coil calibration constant uncertainty	B	0.0217	normal	1	1	0.0217
Current uncertainty	B	0.0087	normal	1	1	0.0087
Imperfect antenna termination influence	B	0.0008	normal	1	1	0.0008
Voltage meas. uncertainty	B	0.0130	normal	1	1	0.0130
Field Homogeneity	B	0.0647	normal	1	1	0.0647
Repeatability	A	0.0024	normal	1	1	0.0024
Total Uncertainty (k=1)						0.070

3.3 Frequency: 1 kHz (measurement in Helmholtz Coils)

Uncertainty budget @ the frequency of 1 kHz						
Source of uncertainty	Type	Value (dB)	Probability distribution	k-factor	Sensitivity coefficient	Standard Uncertainty (dB)
Helmholtz coil calibration constant uncertainty	B	0.0217	normal	1	1	0.0217
Current uncertainty	B	0.0087	normal	1	1	0.0087
Imperfect antenna termination influence	B	0.0008	normal	1	1	0.0008
Voltage meas. uncertainty	B	0.0130	normal	1	1	0.0130
Field Homogeneity	B	0.0647	normal	1	1	0.0647
Repeatability	A	0.0024	normal	1	1	0.0024
Total Uncertainty (k=1)						0.070

3.4 Frequency: 10 kHz (measurement in Helmholtz Coils)

Uncertainty budget @ the frequency of 10 kHz						
Source of uncertainty	Type	Value (dB)	Probability distribution	k-factor	Sensitivity coefficient	Standard Uncertainty (dB)
Helmholtz coil calibration constant uncertainty	B	0.0217	normal	1	1	0.0217
Current measurement uncertainty	B	0.0997	normal	1	1	0.0997
Imperfect antenna termination influence	B	0.0014	normal	1	1	0.0014
Voltage meas. uncertainty	B	0.0130	normal	1	1	0.0130
Field Homogeneity	B	0.0647	normal	1	1	0.0647
Repeatability	A	0.0042	normal	1	1	0.0042
Total Uncertainty (k=1)						0.122

3.5 Frequency: 100 kHz (measurement in Helmholtz Coils)

Uncertainty budget @ the frequency of 100 kHz						
Source of uncertainty	Type	Value (dB)	Probability distribution	k-factor	Sensitivity coefficient	Standard Uncertainty (dB)
Helmholtz coil calibration constant uncertainty	B	0.0217	normal	1	1	0.0217
Current measurement uncertainty	B	0.0997	normal	1	1	0.0997
Imperfect antenna termination influence	B	0.0044	normal	1	1	0.0044
Voltage meas. uncertainty	B	0.0130	normal	1	1	0.0130
Field Homogeneity	B	0.0647	normal	1	1	0.0647
Repeatability	A	0.0016	normal	1	1	0.0016
Total Uncertainty (k=1)						0.122

3.6 Frequency: 100 kHz (measurement with reference antenna)

Uncertainty budget @ the frequency of 100 kHz						
Source of uncertainty	Type	Value (dB)	Probability distribution	k-factor	Sensitivity coefficient	Standard Uncertainty (dB)
Mismatch uncertainty	B	0.2027	U-shape	1.41	1	0.1433
Antenna factor uncertainty	B	0.1009	normal	1	1	0.1009
Positional effects	B	0.29	rectangular	1.73	1	0.1674
Reference attenuator uncertainty	B	0.0790	normal	1	1	0.0790
Measuring receiver resolution (transmitted power measurement)	B	0.05	rectangular	1.73	1	0.0289
Measuring receiver resolution (received power measurement)	B	0.05	rectangular	1.73	1	0.0289
Repeatability	A	0.0125	normal	1	1	0.0125
Total Uncertainty (k=1)						0.259

3.7 Frequency: 100 kHz (measurement in TEM cell)

Uncertainty budget @ the frequency of 100 kHz						
Source of uncertainty	Type	Value (dB)	Probability distribution	k-factor	Sensitivity coefficient	Standard Uncertainty (dB)
TEM cell septum distance	B	0.0864	rectangular	1.73	1	0.0499
TEM cell impedance	B	0.0433	rectangular	1.73	1	0.0250
TEM cell output mismatch	B	0.05	normal	1	1	0.0500
Power meter uncertainty (at TEM cell output)	B	0.080	normal	1	1	0.0800
Power meter uncertainty (at antenna output)	B	0.060	normal	1	1	0.0600
Antenna-power meter mismatch uncertainty	B	0.0839	U-shape	1.41	1	0.0593
Field homogeneity	B	0.60	rectangular	1.73	1	0.3464
Repeatability	A	0.0119	normal	1	1	0.0119
Total Uncertainty (k=1)						0.373

3.8 Frequency: 1 MHz (measurement in Helmholtz Coils)

Uncertainty budget @ the frequency of 1 MHz						
Source of uncertainty	Type	Value (dB)	Probability distribution	k-factor	Sensitivity coefficient	Standard Uncertainty (dB)
Helmholtz coil calibration constant uncertainty	B	0.0217	normal	1	1	0.0217
Current uncertainty	B	0.1814	normal	1	1	0.1814
Output power measurement uncertainty	B	0.05	normal	1	1	0.0500
Mismatch uncertainty	B	0.0863	U-shape	1.41	1	0.0610
Field Homogeneity	B	0.0647	normal	1	1	0.0647
Repeatability	A	0.0025	normal	1	1	0.0025
Total Uncertainty (k=1)						0.209

3.9 Frequency: 1 MHz (measurement with reference antenna)

Uncertainty budget @ the frequency of 1 MHz						
Source of uncertainty	Type	Value (dB)	Probability distribution	k-factor	Sensitivity coefficient	Standard Uncertainty (dB)
Mismatch uncertainty	B	0.2085	U-shape	1.41	1	0.1474
Antenna factor uncertainty	B	0.1009	normal	1	1	0.1009
Positional effects	B	0.29	rectangular	1.73	1	0.1674
Reference attenuator uncertainty	B	0.0790	normal	1	1	0.0790
Measuring receiver resolution (transmitted power measurement)	B	0.05	rectangular	1.73	1	0.0289
Measuring receiver resolution (received power measurement)	B	0.05	rectangular	1.73	1	0.0289
Repeatability	A	0.0473	normal	1	1	0.0473
Total Uncertainty (k=1)						0.265

3.10 Frequency: 1 MHz (measurement in TEM cell)

Uncertainty budget @ the frequency of 1 MHz						
Source of uncertainty	Type	Value (dB)	Probability distribution	k-factor	Sensitivity coefficient	Standard Uncertainty (dB)
TEM cell septum distance	B	0.0864	rectangular	1.73	1	0.0499
TEM cell impedance	B	0.0433	rectangular	1.73	1	0.0250
TEM cell output mismatch	B	0.05	normal	1	1	0.0500
Power meter uncertainty (at TEM cell output)	B	0.080	normal	1	1	0.0800
Power meter uncertainty (at antenna output)	B	0.060	normal	1	1	0.0600
Antenna-power meter mismatch uncertainty	B	0.0863	U-shape	1.41	1	0.0610
Field homogeneity	B	0.60	rectangular	1.73	1	0.3464
Repeatability	A	0.0839	normal	1	1	0.0839
Total Uncertainty (k=1)						0.383

3.11 Frequency: 10 MHz (measurement in Helmholtz Coils)

Uncertainty budget @ the frequency of 10 MHz						
Source of uncertainty	Type	Value (dB)	Probability distribution	k-factor	Sensitivity coefficient	Standard Uncertainty (dB)
Helmholtz coil calibration constant uncertainty	B	0.0217	normal	1	1	0.0217
Current uncertainty	B	0.256	normal	1	1	0.2560
Output power measurement uncertainty	B	0.05	normal	1	1	0.0500
Mismatch uncertainty	B	0.0762	U-shape	1.41	1	0.0539
Field Homogeneity	B	0.0647	normal	1	1	0.0647
Repeatability	A	0.081	normal	1	1	0.0810
Total Uncertainty (k=1)						0.287

3.12 Frequency: 10 MHz (measurement with reference antenna)

Uncertainty budget @ the frequency of 10 MHz						
Source of uncertainty	Type	Value (dB)	Probability distribution	k-factor	Sensitivity coefficient	Standard Uncertainty (dB)
Mismatch uncertainty	B	0.1841	U-shape	1.41	1	0.1302
Antenna factor uncertainty	B	0.1010	normal	1	1	0.1010
Positional effects	B	0.29	rectangular	1.73	1	0.1674
Reference attenuator uncertainty	B	0.0790	normal	1	1	0.0790
Measuring receiver resolution (transmitted power measurement)	B	0.05	rectangular	1.73	1	0.0289
Measuring receiver resolution (received power measurement)	B	0.05	rectangular	1.73	1	0.0289
Repeatability	A	0.0239	normal	1	1	0.0239
Total Uncertainty (k=1)						0.252

3.13 Frequency: 10 MHz (measurement in TEM cell)

Uncertainty budget @ the frequency of 10 MHz						
Source of uncertainty	Type	Value (dB)	Probability distribution	k-factor	Sensitivity coefficient	Standard Uncertainty (dB)
TEM cell septum distance	B	0.0864	rectangular	1.73	1	0.0499
TEM cell impedance	B	0.0433	rectangular	1.73	1	0.0250
TEM cell output mismatch	B	0.05	normal	1	1	0.0500
Power meter uncertainty (at TEM cell output)	B	0.080	normal	1	1	0.0800
Power meter uncertainty (at antenna output)	B	0.060	normal	1	1	0.0600
Antenna-power meter mismatch uncertainty	B	0.0762	U-shape	1.41	1	0.0539
Field homogeneity	B	0.60	rectangular	1.73	1	0.3464
Repeatability	A	0.0824	normal	1	1	0.0824
Total Uncertainty (k=1)						0.381

EURAMET Supplementary Comparison: EURAMET.EM.RF-S27

Antenna factor for Loop Antennas

1 General Information

Laboratory Name:	Czech Metrology Institute, Department of Electromagnetic Quantities
Author:	Dr. Josef Kupec, Michal Ulvr
Date:	15.-20.3. 2012
Laboratory Temperature range:	22,1-23,4 °C

2 Measurements procedure

2.1 Measurement method 1 (low frequency)

2.1.1 Method

Coil standard of magnetic flux density (self made, No. 1201) was used. It is Helmholtz solenoid - diameter 337,5 mm, one layer of windings with 0,75 mm copper wire (20 + 20 windings), leading of thread 1,8 mm, wound on glass-textit frame. Homogeneity of B was measured and calculated for the space of pick-up coil HZ-10. Correction for inhomogeneity (less than 0,5 %) was made. Solenoid was fed with generator Agilent 33220A. Current through windings was measured with calibrated voltmeter HP 34401A and standard resistor. Induced voltage was measured with voltmeter 3458A through 50Ω resistor. Nominal constant of solenoid is 100 μT/A. It was calibrated by comparing with standard quartz solenoid for DC and low frequency. Resonance frequency of solenoid No. 1201 was measured (535 kHz). Correction of constant of solenoid for higher frequencies (from 10 kHz to 100 kHz) was made. For example about 3,4 % for 100 kHz. Magnetic field strength H (A·m⁻¹) was calculated:

$$H = K_H \cdot I$$

where K_H (m⁻¹) is H-constant of the coil and I (A) is current.

The complex reflection coefficient of the antenna was calculated from measured impedance values (using LCR meter).

2.1.2 Measuring equipment

- multimeter HP 34401A
- multimeter Agilent 3458A
- generator Agilent 33220A
- coil standard of magnetic flux density, No. 1201
- resistor standard Tinsley 0,1 Ω, type 1682
- resistor Fluke, type A40
- multi-frequency LCR meter HP 4274A

2.2 Measurement method 2 (high frequency)

2.2.1 Method

2.2.2 Measuring equipment

2.3 Measurement method 3 (... if needed)

2.3.1 Method

2.3.2 Measuring equipment

3 Detailed Uncertainty budget for Antenna Factor

3.1 Frequency: 10 Hz

Uncertainty budget at the frequency of 10 Hz						
Source of uncertainty	Type	Value (%)	Probability distribution	k-factor	Sensitivity coefficient	Standard Uncertainty (dB)
Uncertainty at induced voltage measurement	B	0,80	Norm.	1	1	0,070
Uncertainty at current measurement	B	1,00	Norm.	1	1	0,086
Uncertainty of constant of standard B and its frequency correction	B	0,10	Norm.	1	1	0,009
Uncertainty of correction of inhomogeneity of B	B	0,10	Norm.	1	1	0,009
Uncertainty of value of 50Ω resistor	B	0,10	Norm.	1	0,17	0,002
Repeatability (place of pick-up coil in B solenoid, current, voltage)	A	1,20	Norm.	1	1	0,104
Total Uncertainty (k=1)						0,15

3.2 Frequency: 100 Hz

Uncertainty budget at the frequency of 100 Hz						
Source of uncertainty	Type	Value (%)	Probability distribution	k-factor	Sensitivity coefficient	Standard Uncertainty (dB)
Uncertainty at induced voltage measurement	B	0,25	Norm.	1	1	0,022
Uncertainty at current measurement	B	0,30	Norm.	1	1	0,026
Uncertainty of constant of standard B and its frequency correction	B	0,10	Norm.	1	1	0,009
Uncertainty of correction of inhomogeneity of B	B	0,10	Norm.	1	1	0,009
Uncertainty of value of 50Ω resistor	B	0,10	Norm.	1	0,17	0,002
Repeatability (place of pick-up coil in B solenoid, current, voltage)	A	0,25	Norm.	1	1	0,022
Total Uncertainty (k=1)						0,04

3.3 Frequency: 1 kHz

Uncertainty budget at the frequency of 1 kHz						
Source of uncertainty	Type	Value (%)	Probability distribution	k-factor	Sensitivity coefficient	Standard Uncertainty (dB)
Uncertainty at induced voltage measurement	B	0,25	Norm.	1	1	0,022
Uncertainty at current measurement	B	0,30	Norm.	1	1	0,026
Uncertainty of constant of standard B and its frequency correction	B	0,10	Norm.	1	1	0,009
Uncertainty of correction of inhomogeneity of B	B	0,10	Norm.	1	1	0,009
Uncertainty of value of 50Ω resistor	B	0,10	Norm.	1	0,17	0,002
Repeatability (place of pick-up coil in B solenoid, current, voltage)	A	0,25	Norm.	1	1	0,022
Total Uncertainty (k=1)						0,04

3.4 Frequency: 10 kHz

Uncertainty budget at the frequency of 10 kHz						
Source of uncertainty	Type	Value (%)	Probability distribution	k-factor	Sensitivity coefficient	Standard Uncertainty (dB)
Uncertainty at induced voltage measurement	B	0,30	Norm.	1	1	0,026
Uncertainty at current measurement	B	0,40	Norm.	1	1	0,035
Uncertainty of constant of standard B and its frequency correction	B	0,20	Norm.	1	1	0,017
Uncertainty of correction of inhomogeneity of B	B	0,10	Norm.	1	1	0,009
Uncertainty of value of 50Ω resistor	B	0,40	Norm.	1	0,17	0,006
Repeatability (place of pick-up coil in B solenoid, current, voltage)	A	0,30	Norm.	1	1	0,026
Total Uncertainty (k=1)						0,05

3.5 Frequency: 100 kHz

Uncertainty budget at the frequency of 100 kHz						
Source of uncertainty	Type	Value (%)	Probability distribution	k-factor	Sensitivity coefficient	Standard Uncertainty (dB)
Uncertainty at induced voltage measurement	B	1,40	Norm.	1	1	0,12
Uncertainty at current measurement	B	1,60	Norm.	1	1	0,14
Uncertainty of constant of standard B and its frequency correction	B	0,50	Norm.	1	1	0,04
Uncertainty of correction of inhomogeneity of B	B	0,20	Norm.	1	1	0,02
Repeatability (place of pick-up coil in B solenoid, current, voltage)	A	0,90	Norm.	1	1	0,08
Total Uncertainty (k=1)						0,20

EURAMET Supplementary Comparison: EURAMET.EM.RF-S27

Antenna factor for Loop Antennas

1 General Information

Laboratory Name : TÜBİTAK UME

Authors : Mustafa ÇETİNTAŞ, Osman ŞEN, Soydan ÇAKIR

Date : 11.06.2012 – 08.07.2012

Ambient Temperature: (23 ±2)°C

Humidity : (45 ± 10)%

2 Measurement procedure

2.1 Measurement method 1 (low frequency)

2.1.1 Method

The measurements were performed in accordance with the IEEE Std 291-1991 by using a standard transmitting loop method. The magnetic field value at the distance d from the transmitting antenna was calculated by using equations 1 and 3. A resistor (0.5Ω) was connected in series with the transmitting antenna. The RMS value of the current flowing through the transmitting antenna was calculated by using equation 2. The input impedance of the oscilloscope was adjusted $1 M\Omega$. Measurement setups are given in Figure 1 and Figure 2 for related frequency ranges. In measurements, the distance d for each frequency;

0,15 m for 10 Hz

0,30 m for the frequency range 20 Hz – 100 kHz

$$E = \frac{60AI}{(R_0)^3} \left[1 + \left(\frac{2\pi R_0}{d} \right)^2 \right]^{1/2} \quad (1)$$

$$I = \frac{V}{R} \quad (2)$$

Where:

$$R_0 = [d + r_1^2 + r_2^2]^{1/2}$$

E = Magnitude of the equivalent free-space RMS electric field strength, in V/m

A = Area of the transmitting loop antenna, in m^2

I = RMS current in the transmitting loop, assumed uniform around the loop, in A

λ = Free-space wavelength, in m

d = Distance between the centers of the transmitting and receiving loop antenna, in m

r_1 = Mean radius of the transmitting loop antenna, in m

r_2 = Mean radius of the receiving loop antenna, in m

$$H = \frac{E}{\eta_0} \quad (3)$$

H = Magnetic field. strength in A/m

η_0 = Impedance of free space, equal to approximately 377Ω

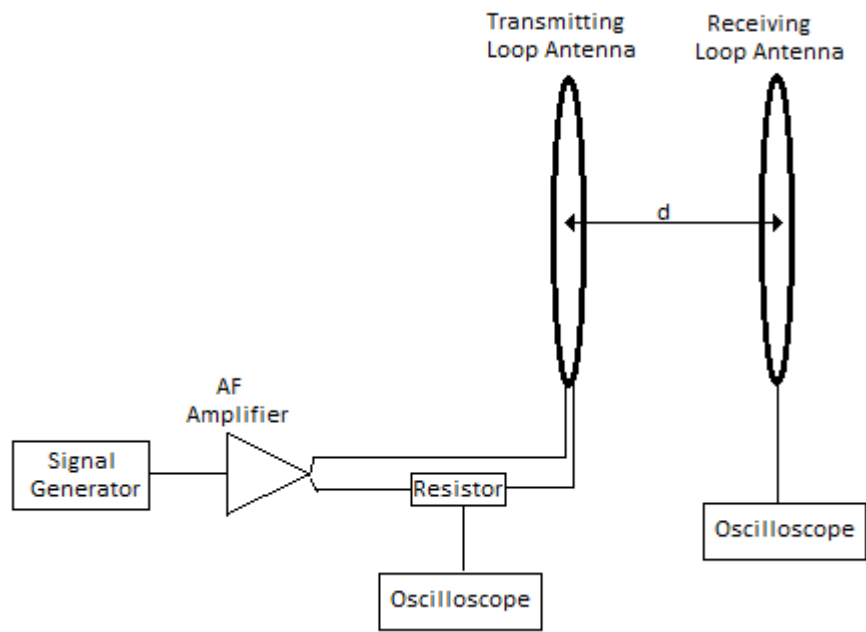

Figure 1. Calibration setup for 10 Hz

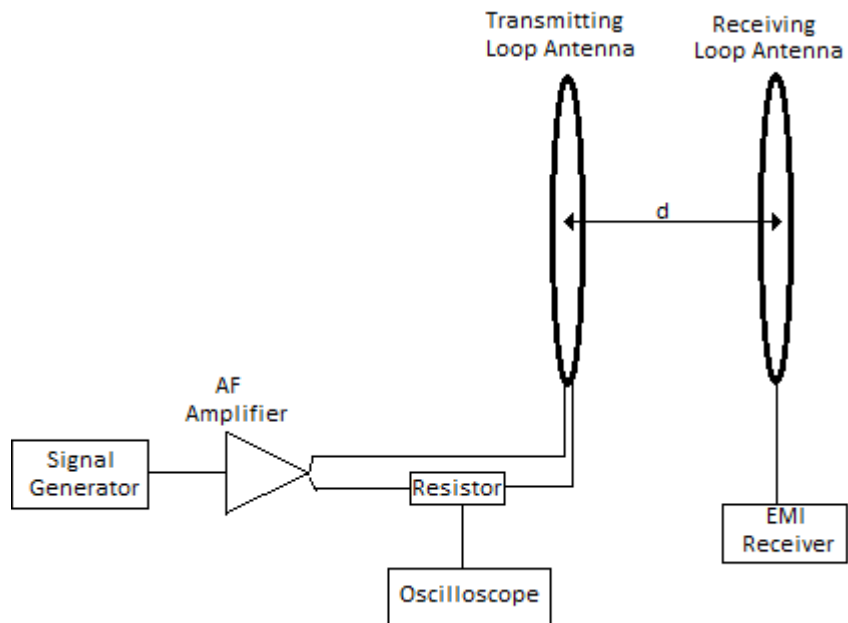

Figure 2. Calibration setup for antenna for the frequency range 20 Hz – 100 kHz



Figure 3. An example photograph taken during the calibration of the loop antenna for the frequency range 10 Hz – 100 kHz

2.1.2 Measuring equipment

Name of Equipment	Manufacturer	Type / Model	Serial No
Oscilloscope	Agilent Technologies	54624A	MY40003040
Oscilloscope	Agilent Technologies	54830B	MY41000992
EMI Receiver	Rohde & Schwarz	ESIB40	100151/040
Transmitting Loop Antenna	Solar Electronics	9230-1	031609
Attenuator Set	Agilent Technologies	11582A	50754
Signal Generator	Agilent Technologies	33120A	MY40024613
AF Amplifier	Bryston	7BSST-230	202

2.2 Measurement method 2 (high frequency)

2.2.1 Method

The measurements were performed in accordance with the IEEE Std 291-1991 by using a standard transmitting loop method. The magnetic field value at the distance d from the transmitting antenna was calculated by using equations 1 and 2. The input impedance of the oscilloscope was adjusted 1 M Ω . The current values of the transmitter loops (Schwarzbeck Mess - Elektronik HFRA 5152 and HFRA 5154) were measured as a voltage drop across the built-in impedances inside the loops. Measurement setup is given in Figure 4. In measurements, the distance d for each frequency;

0,25 m for the frequency range 200 kHz – 1 MHz

0,15 m for the frequency range 2 MHz – 10 MHz

$$E = \frac{60AI}{(R_0)^3} \left[1 + \left(\frac{2\pi R_0}{d} \right)^2 \right]^{1/2} \quad (1)$$

Where:

$$R_0 = [d^2 + r_1^2 + r_2^2]^{1/2}$$

E = Magnitude of the equivalent free-space RMS electric field strength, in V/m

A = Area of the transmitting loop antenna, in m²

I = RMS current in the transmitting loop, assumed uniform around the loop, in A

λ = Free-space wavelength, in m

d = Distance between the centers of the transmitting and receiving loop antenna, in m

r_1 = Mean radius of the transmitting loop antenna, in m

r_2 = Mean radius of the receiving loop antenna, in m

$$H = \frac{E}{\eta_0} \quad (2)$$

H = Magnetic field. strength in A/m

η_0 = Impedance of free space, equal to approximately 377 Ω

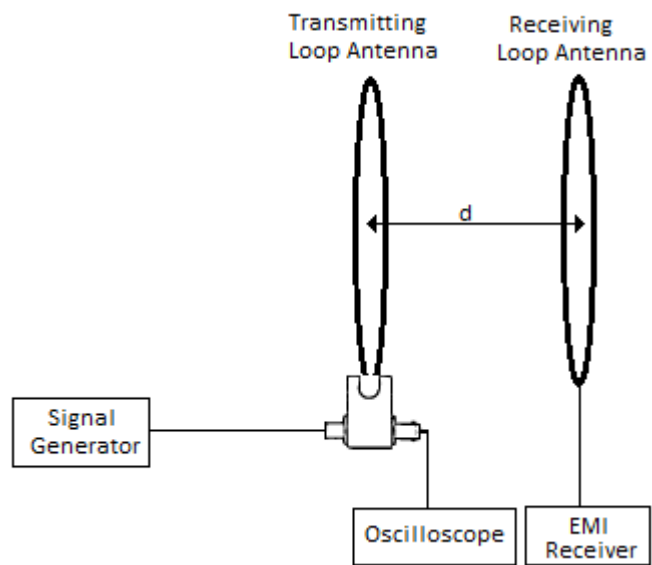

Figure 4. Calibration setup for antenna for the frequency range 200 kHz – 10 MHz

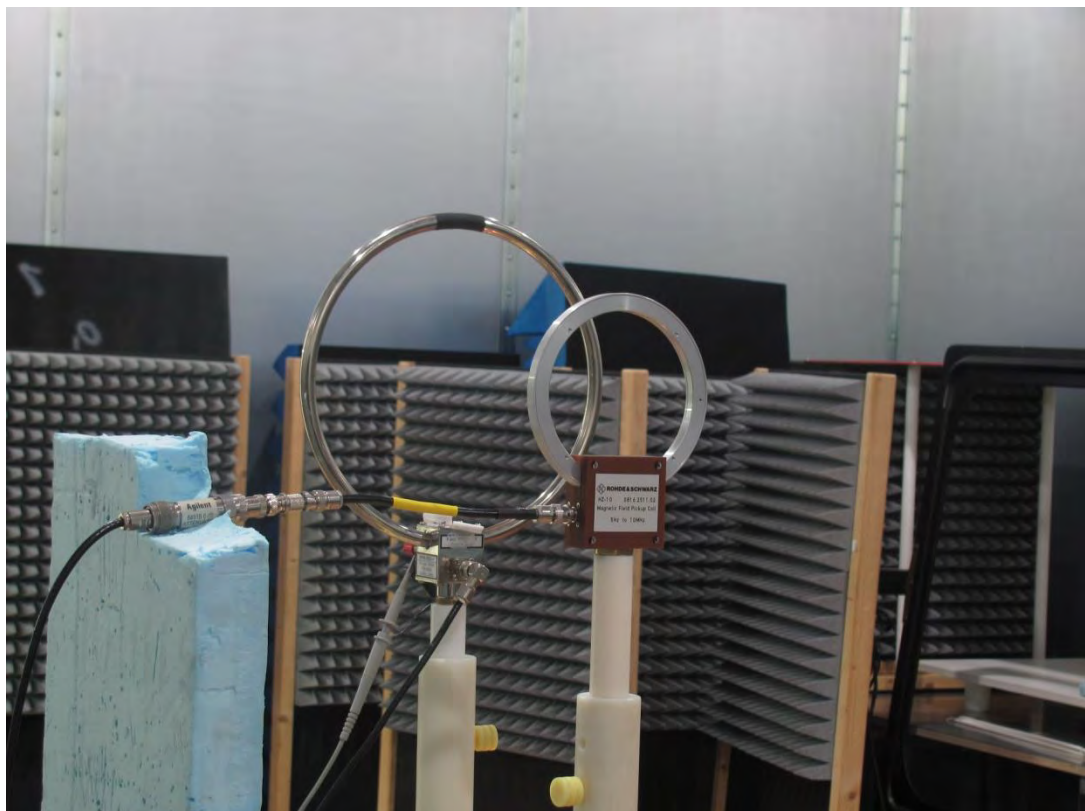

Figure 5. An example photograph taken during the calibration of loop antenna for the frequency range 200 kHz – 1 MHz



Figure 6. An example photograph taken during the calibration of loop antenna for the frequency range 2 MHz – 10 MHz

2.2.2 Measuring equipment

Name of Equipment	Manufacturer	Type / Model	Serial No
Oscilloscope	Agilent Technologies	54624A	MY40003040
EMI Receiver	Rohde & Schwarz	ESIB40	100151/040
Transmitting Loop Antenna	Schwarzbeck Mess - Elektronik	HFRA 5152	5152-017
Transmitting Loop Antenna	Schwarzbeck Mess - Elektronik	HFRA 5154	5154-011
Attenuator Set	Agilent Technologies	11582A	50754
Signal Generator	Agilent Technologies	33120A	MY40024613

2.3 Measurements results

Frequency	Free Field antenna factor (AF)	Total Standard Uncertainty on AF (k=1)	S11 parameter (Real Part)	S11 parameter (Imaginary Part)	Total Standard Uncertainty on Re[S11] (k=1)	Total Standard Uncertainty on Im[S11] (k=1)
(Hz)	(dB(S/m))	(dB)				
10	88,50	0,83	-0,654	0,001	0,010	0,010
20	83,49	0,80	-0,654	0,002	0,010	0,010
30	79,65	0,80	-0,654	0,003	0,010	0,010
40	76,96	0,80	-0,655	0,003	0,010	0,010
50	74,89	0,80	-0,655	0,004	0,010	0,010
60	73,31	0,80	-0,655	0,005	0,010	0,010
70	71,93	0,80	-0,655	0,006	0,010	0,010
80	70,77	0,80	-0,655	0,007	0,010	0,010
90	69,73	0,80	-0,655	0,008	0,010	0,010
100	68,81	0,80	-0,655	0,008	0,010	0,010
200	62,81	0,80	-0,655	0,017	0,010	0,010
300	59,27	0,80	-0,654	0,025	0,010	0,010
400	56,79	0,80	-0,654	0,033	0,010	0,010
500	54,93	0,80	-0,653	0,041	0,010	0,010
600	53,38	0,80	-0,652	0,049	0,010	0,010
700	52,10	0,80	-0,651	0,057	0,010	0,010
800	50,97	0,80	-0,650	0,065	0,010	0,010
900	50,00	0,80	-0,649	0,073	0,010	0,010
1000	49,12	0,80	-0,648	0,081	0,010	0,010
2000	43,43	0,80	-0,632	0,155	0,010	0,010
3000	40,01	0,80	-0,611	0,225	0,010	0,010
4000	37,68	0,80	-0,585	0,291	0,010	0,010
5000	35,85	0,80	-0,556	0,353	0,010	0,010

Frequency	Free Field antenna factor (AF)	Total Standard Uncertainty on AF (k=1)	S11 parameter (Real Part)	S11 parameter (Imaginary Part)	Total Standard Uncertainty on Re[S11] (k=1)	Total Standard Uncertainty on Im[S11] (k=1)
(Hz)	(dB(S/m))	(dB)				
6000	34,44	0,80	-0,522	0,411	0,010	0,010
7000	33,24	0,80	-0,484	0,464	0,010	0,010
8000	32,23	0,80	-0,445	0,514	0,010	0,010
9000	31,40	0,80	-0,403	0,558	0,010	0,010
10000	30,66	0,80	-0,358	0,598	0,010	0,010
20000	26,23	0,80	0,074	0,790	0,010	0,010
30000	24,51	0,80	0,385	0,771	0,010	0,010
40000	23,70	0,80	0,578	0,696	0,010	0,010
50000	23,45	0,80	0,699	0,616	0,010	0,010
60000	23,29	0,80	0,776	0,544	0,010	0,010
70000	23,12	0,80	0,828	0,485	0,010	0,010
80000	23,07	0,80	0,864	0,435	0,010	0,010
90000	22,97	0,80	0,890	0,393	0,010	0,010
100000	22,81	0,80	0,910	0,358	0,010	0,010
200000	21,26	0,70	0,977	0,180	0,010	0,010
300000	21,44	0,70	0,990	0,112	0,010	0,010
400000	21,79	0,70	0,995	0,074	0,010	0,010
500000	21,85	0,70	0,997	0,049	0,010	0,010
600000	21,99	0,70	0,998	0,031	0,010	0,010
700000	22,06	0,70	0,999	0,016	0,010	0,010
800000	22,08	0,70	0,999	0,003	0,010	0,010
900000	22,08	0,70	0,999	-0,008	0,010	0,010
1000000	22,10	0,70	0,999	-0,018	0,010	0,010

Frequency	Free Field antenna factor (AF)	Total Standard Uncertainty on AF (k=1)	S11 parameter (Real Part)	S11 parameter (Imaginary Part)	Total Standard Uncertainty on Re[S11] (k=1)	Total Standard Uncertainty on Im[S11] (k=1)
(Hz)	(dB(S/m))	(dB)				
2000000	22,09	0,70	0,994	-0,096	0,010	0,010
3000000	22,34	0,70	0,985	-0,160	0,010	0,010
4000000	22,79	0,70	0,972	-0,223	0,010	0,010
5000000	23,17	0,70	0,953	-0,285	0,010	0,010
6000000	23,81	0,70	0,925	-0,349	0,010	0,010
7000000	24,75	0,70	0,889	-0,407	0,010	0,010
8000000	26,21	0,70	0,842	-0,473	0,010	0,010
9000000	26,88	0,70	0,754	-0,516	0,010	0,010
10000000	25,71	0,70	0,741	-0,485	0,010	0,010

3 Detailed Uncertainty budget for Antenna Factor

3.1 Frequency: 10 Hz

Uncertainty budget @ the frequency of Hz						
Source of uncertainty	Type	Value	Probability distribution	k-factor	Sensitivity coefficient	Standard Uncertainty (dB)
Distortion of the transmitting loop antenna	B	0,40	Triangle	2,45	1,00	0,16
Resistor	B	0,30	Rectangular	1,73	1,00	0,17
Oscilloscope (for transmitting loop)	B	0,20	Rectangular	1,73	1,00	0,12
Distance	B	0,15	Rectangular	1,73	1,00	0,09
Reflection	B	0,40	Rectangular	1,73	1,00	0,23
Alignment of antennas	B	0,30	Rectangular	1,73	1,00	0,17
Oscilloscope (for receiving loop)	B	0,80	Rectangular	1,73	1,00	0,46
Cable Loss Uncertainty	B	0,25	Rectangular	1,73	1,00	0,14
Mismatch at resistor to oscilloscope	B	0,15	U-shaped	1,41	1,00	0,11
Mismatch at resistor to transmitting loop antenna	B	0,15	U-shaped	1,41	1,00	0,11
Mismatch at receiving loop antenna to oscilloscope	B	0,15	U-shaped	1,41	1,00	0,11
Calibration area	B	0,25	Triangle	2,45	1,00	0,10
Measurement repeatability	A	0,50	Normal	1,00	1,00	0,50
Total Uncertainty (k=1)						0,83

3.2 Frequency Range: 100 Hz – 900 kHz

Uncertainty budget @ the frequency of Hz						
Source of uncertainty	Type	Value	Probability distribution	k-factor	Sensitivity coefficient	Standard Uncertainty (dB)
Distortion of the transmitting loop antenna	B	0,40	Triangle	2,45	1,00	0,16
Resistor	B	0,30	Rectangular	1,73	1,00	0,17
Oscilloscope (for transmitting loop)	B	0,20	Rectangular	1,73	1,00	0,12
Distance	B	0,15	Rectangular	1,73	1,00	0,09
Reflection	B	0,40	Rectangular	1,73	1,00	0,23
Alignment of antennas	B	0,30	Rectangular	1,73	1,00	0,17
EMI Receiver	B	0,70	Rectangular	1,73	1,00	0,40
Cable Loss Uncertainty	B	0,25	Rectangular	1,73	1,00	0,14
Mismatch at resistor to oscilloscope	B	0,15	U-shaped	1,41	1,00	0,11
Mismatch at resistor to transmitting loop antenna	B	0,15	U-shaped	1,41	1,00	0,11
Mismatch at receiving loop antenna to EMI Receiver	B	0,15	U-shaped	1,41	1,00	0,11
Calibration area	B	0,25	Triangle	2,45	1,00	0,10
Measurement repeatability	A	0,50	Normal	1,00	1,00	0,50
Total Uncertainty (k=1)						0,80

3.3 Frequency Range: 1 MHz – 10 MHz

Uncertainty budget @ the frequency of Hz						
Source of uncertainty	Type	Value	Probability distribution	k-factor	Sensitivity coefficient	Standard Uncertainty (dB)
Distortion of the transmitting loop antenna	B	0,40	Triangle	2,45	1,00	0,16
Resistor	B	0,30	Rectangular	1,73	1,00	0,17
Oscilloscope (for transmitting loop)	B	0,20	Rectangular	1,73	1,00	0,12
Distance	B	0,15	Rectangular	1,73	1,00	0,09
Reflection	B	0,40	Rectangular	1,73	1,00	0,23
Alignment of antennas	B	0,30	Rectangular	1,73	1,00	0,17
EMI Receiver	B	0,70	Rectangular	1,73	1,00	0,40
Cable Loss Uncertainty	B	0,30	Rectangular	1,73	1,00	0,17
Mismatch at resistor to oscilloscope	B	0,15	U-shaped	1,41	1,00	0,11
Mismatch at resistor to transmitting loop antenna	B	0,15	U-shaped	1,41	1,00	0,11
Mismatch at receiving loop antenna to EMI Receiver	B	0,15	U-shaped	1,41	1,00	0,11
Calibration area	B	0,25	Triangle	2,45	1,00	0,10
Measurement repeatability	A	0,30	Normal	1,00	1,00	0,30
Total Uncertainty (k=1)						0,70